

California Energy Commission

DOCKETED

14-BSTD-01

TN # 74282

JAN 13 2015

December 10, 2014

Mr. Andrew McAlister
Commissioner
California Energy Commission
1516 Ninth Street
Sacramento, California 95814

Eaton's Cooper Lighting Business Comments on Staff Workshop on Proposed Lighting Efficiency Measure for Residential and Nonresidential Buildings

Dear Commissioner McAllister,

Eaton's Cooper Lighting (hereafter referred to as "Cooper") would like to thank you for the opportunity to provide comments on the California Energy Commission's Staff Workshop on Proposed Lighting Efficiency Measures for Residential and Nonresidential Buildings.

Eaton is a leading diversified, global power management company that is fundamentally committed to helping the world to use less energy and to use energy safely. Our innovative technologies and services help customers manage electrical, hydraulic and mechanical power, safely and efficiently. In addition, these power management technologies help customers control costs and reduce their energy requirements.

Eaton's Electrical Products and Services businesses are global leaders in power distribution, power quality, control and automation, power monitoring, and energy management products and services. We deliver a range of innovative and reliable indoor and outdoor lighting and controls solutions, specifically designed to maximize performance, energy efficiency and cost savings. The Lighting business serves customers in the commercial, industrial, retail, institutional, residential, utility and other markets. We currently employ over 35,000 people nationwide with over 1,600 of those residing in California.

Eaton has worked hard as an organization to position ourselves as the global leader in the development and sale of solutions aimed at addressing the critical societal goals of reducing emissions and decreasing energy consumption. Eaton provides insight as a global leader in efficient lighting solutions and a major stakeholder in the electrical industry. Our comments are aimed at helping deliver to our customers energy savings at the least cost with improved performance.

Please see our comments below

Residential

We strongly support the requirement of High Efficacy in all spaces.

We appreciate the fact that you have a selection of lighting sources listed as high efficacy, but are concerned that the requirements for LED sources, such as CRI for example in JA8, are much more stringent than the requirements for other sources. We feel this could lead to lower adoption of more efficacious sources.

Consumers select lighting products based on the intended use. Attributes that may be important for one area may not be as crucial in another area. Consumers like to have a choice in their selections and will make that choice based on cost, performance, and application. For that reason we would recommend continuing to offer the consumer the current option of a range of color temperature from 2700K – 4000K. We feel that only allowing color temperatures 3000K or less is too restrictive and does not provide enough options for the consumer. Understanding that Residential Compliance includes not only standard single family residences but also includes areas such as Senior Living Quarters included as “dwelling”, we find that higher CCTs are often preferred as the eye ages and a limit of 3000K may not be comfortable. We want to ensure that all areas considered as “dwellings” are also considered when proposing requirements..

We suggest that CEC give more consideration to the proposal that would allow screw base lamps in **all** luminaires with the exception of recessed downlights. Our concern is that less energy efficiency technologies could and will be installed after the initial inspection. We suggest continuing the restriction that exist currently in Title 24 2013.

We strongly support the ban of screw base lamps in all recessed luminaires and would suggest adding enclosed luminaries to that ban. We believe that allowing the use of screw base sockets in ICAT downlights and enclosed luminaries will result in misuse of screw based lamp technology creating unreliable results and unsafe conditions leading to consumer dissatisfaction and potential risk of fire. Please see attachment A pertaining specifically to recessed downlights.

The proposals for Joint Appendices JA8 contain requirements for numerous quality attributes for qualified product, some of which are not energy related. While quality is of course a consideration when selecting product, cost and application is also a huge consideration. We believe the CRI 90 requirement and the color rendering R9 value will severely restrict customer choice. While there are more recessed downlight products today that can meet the CRI 90 requirement, there are few surface mounted and linear style LED products that can meet this requirement. If the proposals only allow for premium products with a higher cost you may well see a lower penetration of new technology in California in comparison to other areas of the country. We would ask that you reconsider both the CRI 90 requirement and the color rendering R9 value drafted in the broad application of JA8 for High Efficacy products. We would also ask that the commission consider if the inclusion of 90CRI and a 50R9 value inadvertently provides preferential treatment to those that have patents written specifically around those

performance characteristics creating a potential for restriction of trade that drives product costs up for those that comply with US laws.

While we believe that color uniformity is important. Three to four McAdams-ellipses (3 to 4 SCDM) is sufficient to address residential concerns. Defining it to the black body adds complication due to the loose definition of "source" within the requirements. This favors lamps in suspended air. This does not address thermal and optical color shifts and should be removed since it negatively impacts consumer choice and consumer preferences.

The 45 lumens per watt favors lamps suspended in air. The LED standards have been written around LM-79 with luminaire efficacy paramount. This allows for a 45lpw lamp that will deliver less than 20LPW in a luminaire. We would propose continuing the use of a matrix by luminaire application and/or type using LightingFacts® data analytics to establish the targets.

We are concerned with the inclusion of LED linear tubes in the standards. There are many elements for LED linear tubes that need to be addressed before considering this as a component of the equipment standards. Some items to consider are as follows:

1. LED linear tubes with direct line connection exposes the consumer to direct line voltage at the socket. The risk of shock is higher than with linear fluorescent.
2. LED linear tubes that use a driver and uses standard linear fluorescent sockets creates an incompatibility issue between LED linear tubes and potential misuse when installing a linear fluorescent lamps as a replacement.
3. LED linear tubes that use an existing linear fluorescent ballast to operate and use standard fluorescent sockets offer a reasonable solution yet only certain fluorescent ballast will work both leading to confusion and possibility of misapplication.
4. Dedicated LED linear tubes, dedicated LED sockets, and dedicated drivers offer the best solution for safety. However, we find that integrated luminaires are more cost effective by nearly 20% with efficacies exceeding 120lpw where the luminaire efficacy of these dedicated LED linear tubes have not proven they deliver that level of energy savings.
5. The ambient conditions of LED linear tubes within a luminaire are suspect to exceeding the UL limits and pose the same concerns expressed with screw-in lamps in recessed and enclosed luminaires mentioned earlier.

We would also ask that you review the requirement for recessed luminaires in "dwellings" to be both listed for zero clearance insulation contact (IC) and have a label that certifies that the luminaire is airtight (AT) with air leakage less than 2.0 CFM at 75 Pascals when tested in accordance with ASTM E283. While this is very common for recessed downlight style luminaires it is not as common with recessed linear style luminaires. We would ask that you consider changing the verbiage to allow exceptions for recessed linear (troffer) style luminaires. In many High Rise Residential properties, Hotel/Motels, etc. the dwellings do not have insulated ceilings therefore the IC rating is unnecessary. We believe that possibly troffer styles luminaires were not considered when developing these requirements ICAT troffer luminaires are not normally used in dwellings. These are known to be roughly twice the cost of standard troffers used in residential applications.

We ask that the Commission also consider the requirement for minimum rated life and warranty. This is a financial decision made by the manufacture and is not appropriate in an energy standard.

The .03 required start time will add cost to a product when we have no data to substantiate that start time is an issue. We ask that this requirement be removed or changed to a more reasonable value. With our experiences with dimmers offered in the market, driver technology, and potential nuisances; we recommend to make this 1 second so flicker is avoided and the product is capable to dim to 10% or less.

Please clarify that you have allowed an exception for both Correlated Color Temperature (CCT) and Color Rendering Index (CRI) requirements for residential outdoor lighting. (i.e., equal to or less than 3000K and 90 CRI)

Section 110.9 (c) (4) Mandatory requirements

Track Lighting Integral Current Limiter

“Shall be designed so that the current limiter housing is permanently attached to the track so that the system will be irreparably damaged if the current limiter housing were to be removed after installation into the track. Methods of attachment may include but are not limited to one-way barbs, rivets, and one-way screws”

We ask that the commission review this requirement for possible existing patents. Again, we would be concerned about restriction of trade if in fact this requirement limits this product to only the manufacturer that holds this patent.

Non-Residential Outdoor Lighting

We support a LPA baseline that is based on LED technology; however we have concerns on those baselines being calculated on “projected” 2017 efficiency levels and would like to fully understand how those levels were determined. We would like to fully evaluate the models that were used to calculate the new LPA levels before we further comment on this section

Thank you for the opportunity to comment and we look forward to working with on this important initiative.



Rebecca (Becky) Rainer

Manager, Industry & Government Relations
Eaton's Cooper Lighting Business
5035 Highway 61 South
Vicksburg, MS 39180
tel: +1 601-629-3857

Attachment A

mobile: +1 601-456-3784

fax: +1 601-634-9692

beckyfrainer@eaton.com

www.CooperLighting.com





California Title 24 2016 Proposals – Attachment A

Documents dated October 23, 2014

Published: 2014 11 14



© 2014 Eaton. All rights reserved

Cooper Lighting
by **EATON**

JA8 – Use of E26 base LED lamps in recessed downlights

LED lamps used in ICAT recessed downlights having E26 sockets will result in misuse of the technology creating unreliable results and unsafe conditions



Based upon actual test data from 2013 through 2014 in 6” can (worse for smaller cans!)

- Greater than 13W, can potentially exceed LED lamp manufacturer’s warranty thermal limits in enclosed downlight
- Greater than 23W, can potentially exceed UL 120C limits for plastic when used in enclosed downlight
- Greater than 26W, can potentially exceed UL 120C limits plastic when used in open downlight

Code should not encourage product misuse resulting in poor performance and exceeding UL conditions of acceptability

Comparison of ICAT recessed housings

Halo H7ICAT
Most common

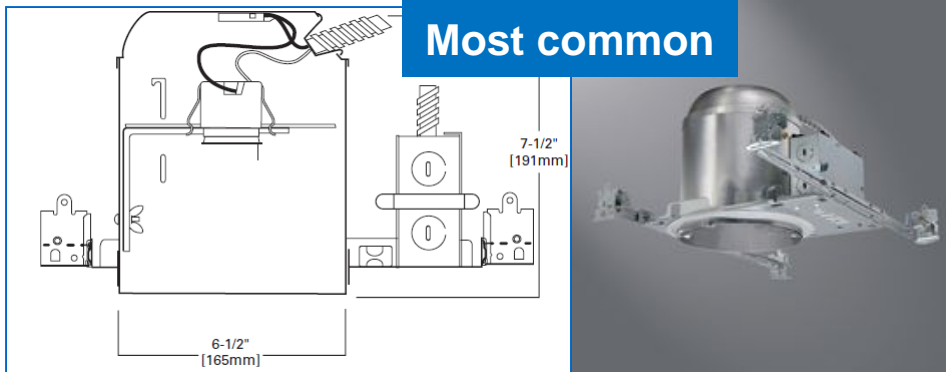

Halo 27ICAT
Common – Shallow construction

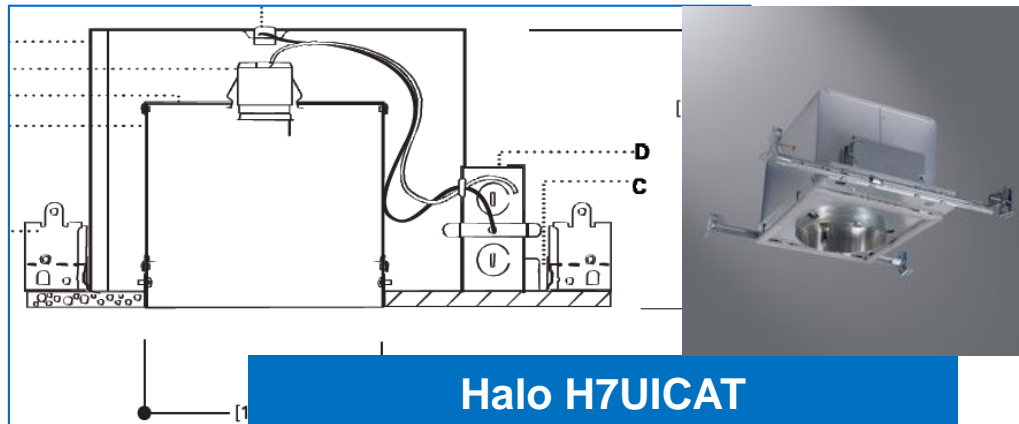
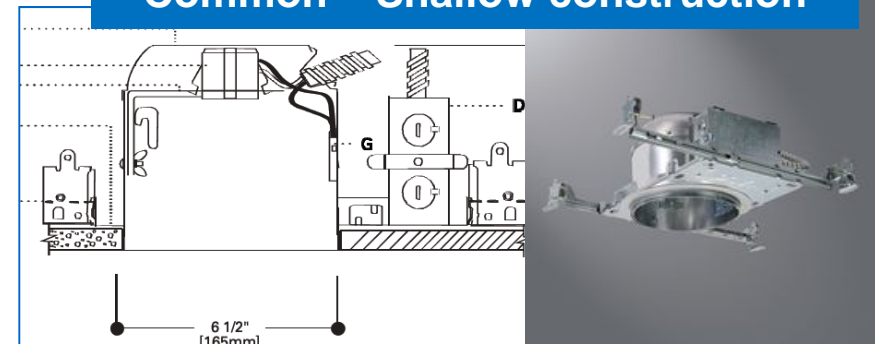

Halo H7UICAT
Least common –
ENERGY STAR® Lamp Test Spec

- LED Lamp test specs do not cover “reality” of what is installed
- LED Lamp specifications not written to address recessed downlighting safety requirements