

DOCKETED	
Docket Number:	24-OPT-02
Project Title:	Compass Energy Storage Project
TN #:	260188
Document Title:	Shoals BESS slide deck
Description:	Powerpoint presentation showing our capabilities for BESS projects.
Filer:	Mike Everson
Organization:	Shoals Technologies Group
Submitter Role:	Public
Submission Date:	11/20/2024 11:47:20 AM
Docketed Date:	11/20/2024



shoals
INVENTING SIMPLE®

Optimizing Battery Energy Storage (BESS) Projects



Our Speaker and Agenda

Today we will discuss

- Introduction to Shoals
- Battery storage market landscape
- BESS project challenges
- Types of battery storage sites
- BESS solutions from Shoals
- How to optimize your BESS projects
- Q&A



Mike Everson

**Account Executive, BESS,
Shoals Technologies Group**

Mike Everson is a BESS Account Executive at Shoals, leading battery energy storage solutions across North America. With over 27 years of experience, he specializes in custom-engineered solutions for power distribution, data centers, and energy storage.

Shoals Technologies Group

27 years of commitment to quality



Shoals Technologies Group™ is a leading provider of electrical balance of systems (EBOS) solutions for solar PV and energy storage. EBOS is all the components of a solar power system that are required to transport electricity from the solar panels to the power grid or storage systems.

HIGHLIGHTS



Founded in 1996 as a Tier 1 automotive supplier



Launched Solar EBOS in 2002



Debuted on the Nasdaq stock exchange in 2021 (SHLS)



Commitment to US manufacturing – Tennessee Mega Plant (680K sqft) in 2025

Sustainable Growth

Where we are and where we are going



Largest EBOS supplier worldwide with over **66 GW** under contract, in construction, and operating



Over **47 patents** issued and pending globally



Headquartered outside Nashville, Tennessee, USA, our products are certified *Made in Tennessee*

GEOGRAPHIES SERVED

● Sales and Business Development team bases in NA, Spain and AUS

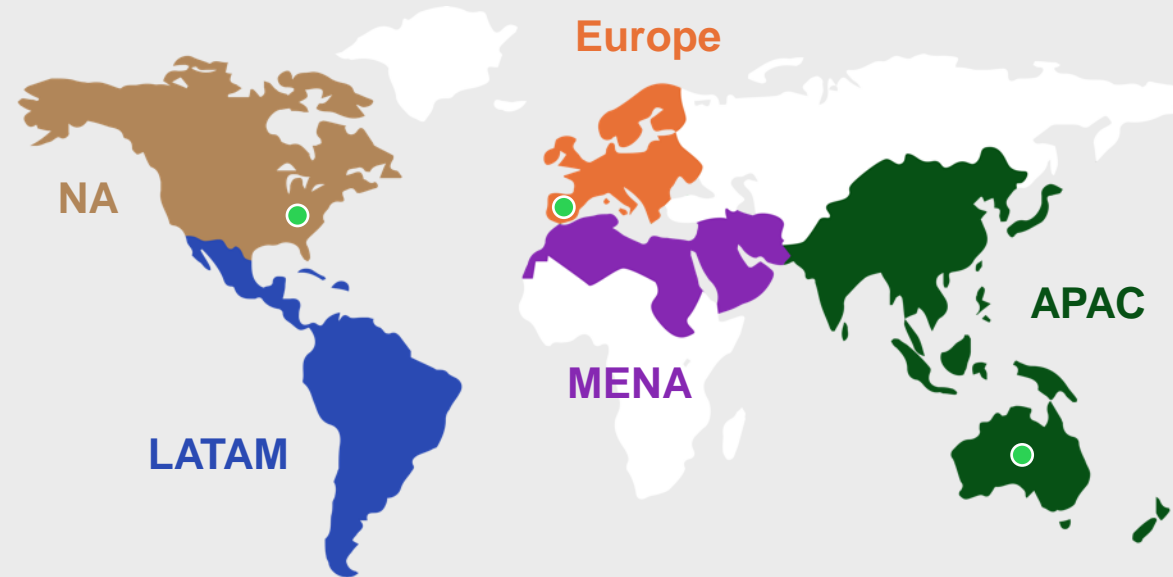

Sample projects from around the world at shoals.com/projects

BESS Market Overview

Battery energy storage system capacity is predicted to grow substantially between now and 2033

- Over 500 utility-scale projects of various sizes are underway across the US.
- Numerous commercial, community, and industrial (CC&I) projects of 20MW or less are also in progress.
- Approximately 2.6x growth between 2024-2033.
- The U.S. battery energy storage market is worth billions USD and continues to grow.

Global Energy Storage Forecast (GWh)*

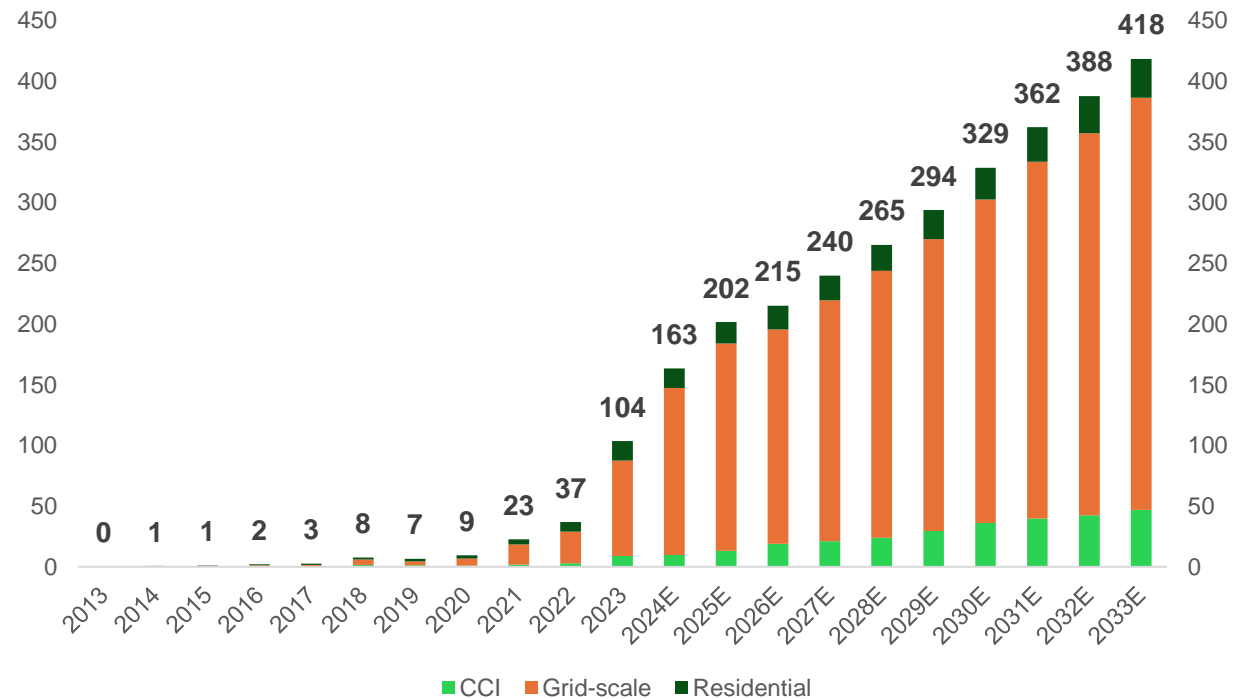

*Wood Mackenzie, Oct 2024

Disclaimer: The data and information provided by Wood Mackenzie should not be interpreted as advice, and you should not rely on it for any purpose. You may not copy or use this data and information except as permitted by Wood Mackenzie in writing. To the fullest extent permitted by law, Wood Mackenzie accepts no responsibility for its use except as specified in a written agreement you may have entered into with Wood Mackenzie for the provision of such data and information.

BESS Challenges

Good News! Shoals BESS solutions are commonly applicable and promote EBOS, helping to distribute DC power and simplify deployments.



CHALLENGE 1

High Cost to Deploy

- Lithium-ion batteries costs are still high
- AC-coupled is higher cost vs. DC-coupled
- Other battery chemistries can lower cost, i.e. flow batteries, sodium-ion, iron-air, EV re-use



CHALLENGE 2

Efficiency

- Power losses during conversion (AC-coupled)
- Need better BMS systems



CHALLENGE 3

Interoperability

- Many different battery technologies may not be compatible
- Need standard communication protocols



CHALLENGE 4

Sustainability

- Major impacts to our environment
- Batteries require a lot of energy to produce
- Disposal of batteries is an issue

BESS System Types – AC Coupled

- Separate inverters for PV & BESS
- Can be discharged at full power
- Power is converted 3 times

PROS	CONS
<ul style="list-style-type: none">▪ Easy retrofit – can add more easily▪ Flexible – uses any inverter▪ Versatile – battery can charge from the grid	<ul style="list-style-type: none">▪ Very high cost▪ Less efficient, power losses, 90-94%▪ Not off grid, no transformers – susceptible to surge load

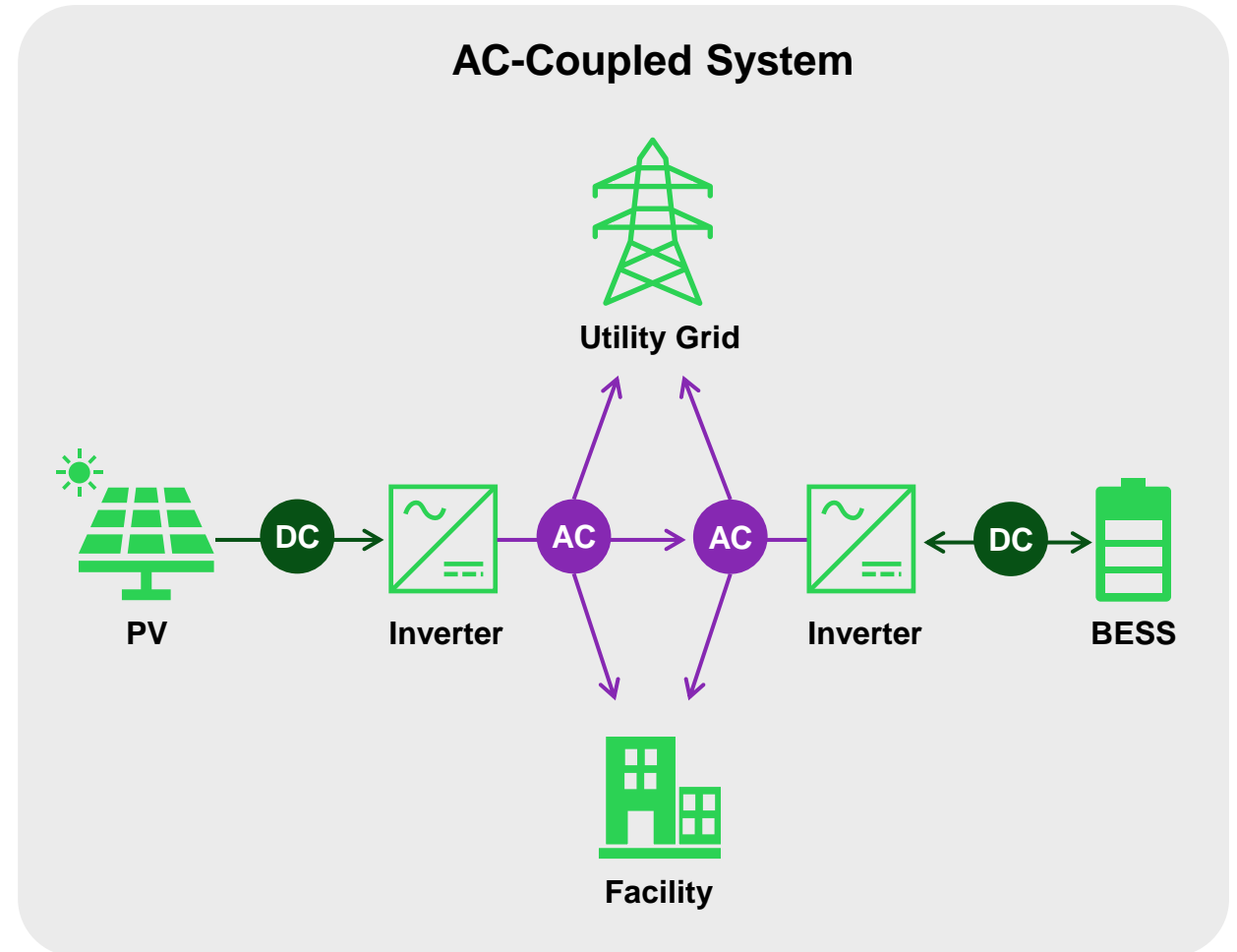

BESS System Types – DC Coupled

- PV and BESS use the same inverter and share the grid interconnection
- Reduced equipment needs and power losses

PROS	CONS
<ul style="list-style-type: none">▪ Affordability – less expensive▪ Higher efficiency – 98%▪ Oversizing – panels can generate more than inverter rating, excess charges the battery (lost in AC system)	<ul style="list-style-type: none">▪ Less flexible – inverter needs to be close by▪ Less resilient – single inverter source of failure

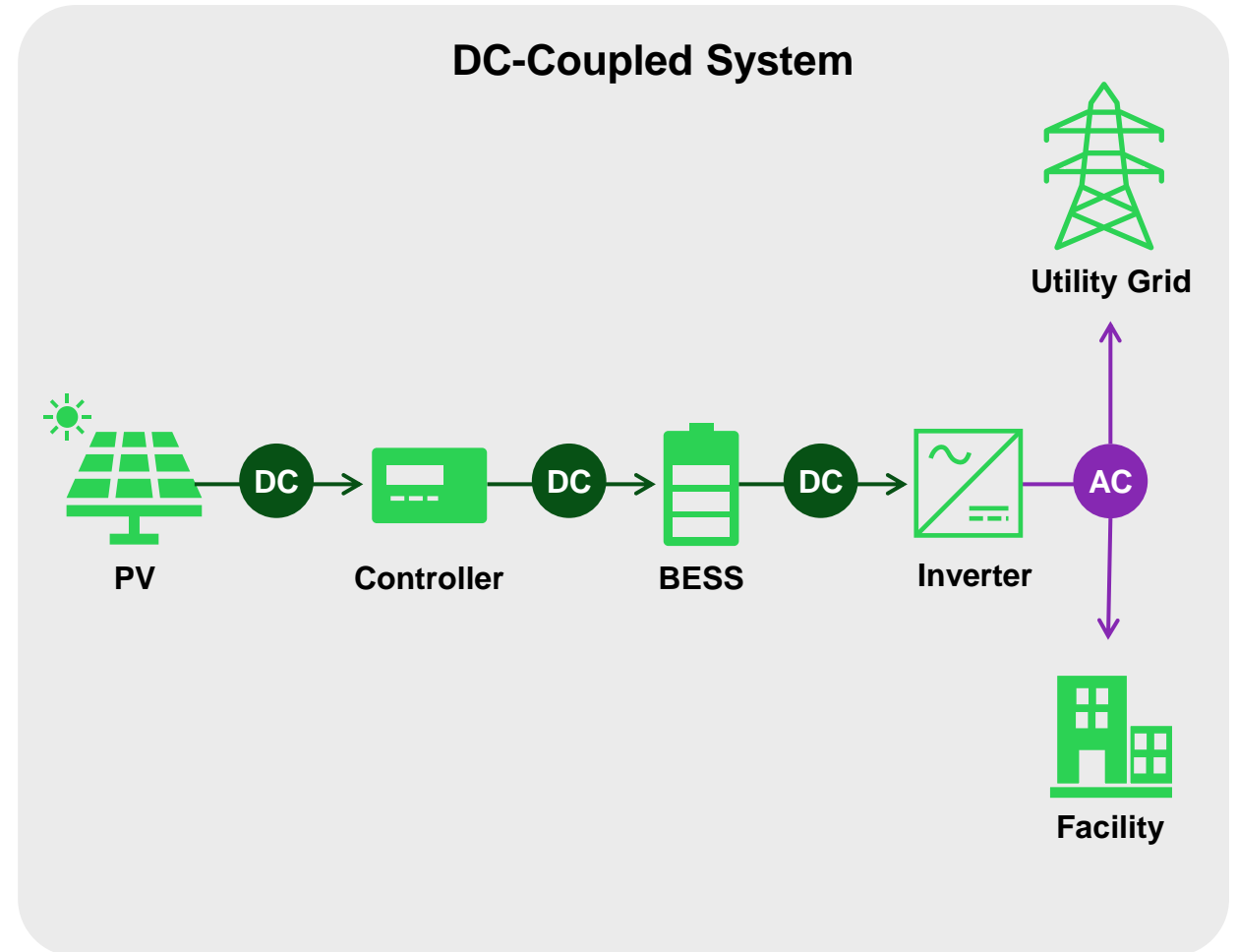

Expert Experience Across the Energy Transition

Solar and Battery Energy Storage Systems

We simplify the complexity of interconnecting the energy transition by moving assembly from the field to the factory, creating products with superior quality, reliability, and safety that can be installed by anyone.



ENERGY STORAGE



Combiners
combine multiple DC circuits, up to 16 into a single output, before the inverter

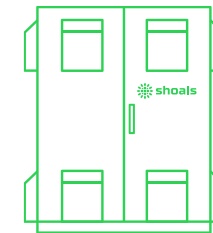

Recombiners
combine multiple combiners from PV, BESS or both, before the inverter



Multi-load break disconnects (MLBDs)
combine multiple disconnects vs. several individual disconnects, resulting in less cable, less gear, faster installs

Custom Solutions – fuse cabinets, auxiliary power cabinets, isolation cabinets, reverse current protection mitigation

BESS Combiner



BESS combiner collects and combines DC inputs from solar arrays, BESS, and other DC microgrid components.

- Allows charging from renewable sources and discharging to provide consistent power to the grid
- Optimizes site layouts
- Lab-proven under full load
- Designed for maximum durability and years of uninterrupted, real-world service



Features

- Finger-safe fuse holders
- Up to 500A, 1500V disconnect, 100% load-break rated
- Plated bus bars rated for 90°C, Cu/Al
- Breather vent reduces internal condensation
- Safety shield covers all live components
- Surge protection device, Type I
- NEMA 3R/4X pad-lockable enclosure
- Standard 5-year warranty
- Compliant with NEC 2017/2020 and ETL certified to UL1741

BESS – Example Combiner Layout

Combiners are typically installed coupling batteries outputs of the BESS system before connecting to the inverter.

- Discrete batteries
- Battery racks
- Containerized batteries

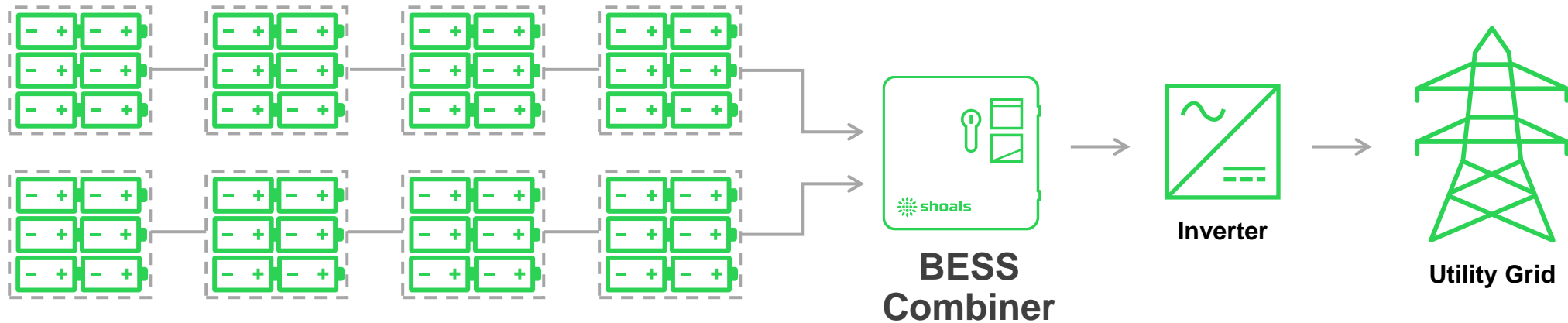

BESS Recombiner

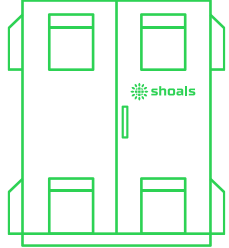

BESS recombiner collects and combines DC inputs from multiple combiners, solar arrays and BESS.

- Allows charging from renewable sources and discharging to provide consistent power to the grid
- Optimizes site layouts moves the recombiner to a centralized location
- Lab-proven under full load
- Designed for maximum durability and years of uninterrupted, real-world service

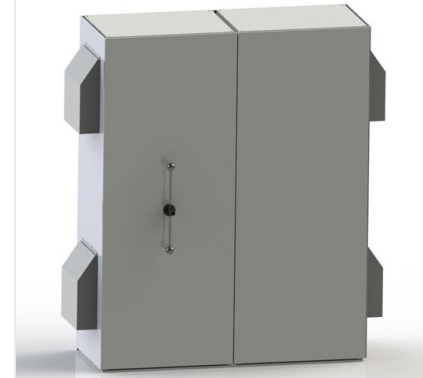

Exterior View:
4000A Output with (8) Input
Fuses in Two Cabinets

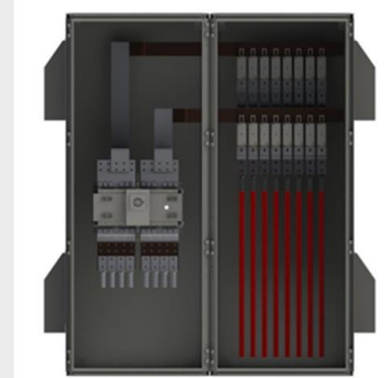

Interior View:
4000A Output with (8) Input
Fuses in Two Cabinets



Exterior View:
2000A Output with (8)
Input Fuses in One
Cabinet

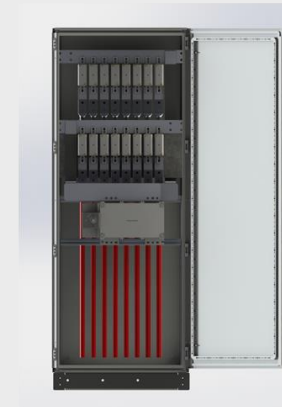

Interior View:
2000A Output with (8)
Input Fuses in One
Cabinet

Features

- 1500V DC
- Up to (8) 630A Fused Inputs per section
- 1200A and 2000A Rated Outputs with Load Break Disconnects
- 4000A Rated Output with non-Load Break Disconnect
- Optional fuses for main output
- Safety Shields over all live parts
- Padlockable Type 3R Free Standing Enclosure
- NRTL certified to UL1741 (2000A max)

BESS – Example Recombiner Layout

- Recoiners are typically installed coupling solar panel outputs to the BESS system to provide bi-directional power flow.
- Solar panels can be used to charge the batteries or export power to the grid through the inverter.
- BESS system discharges power through the recombiner to export power to the grid through the inverter.

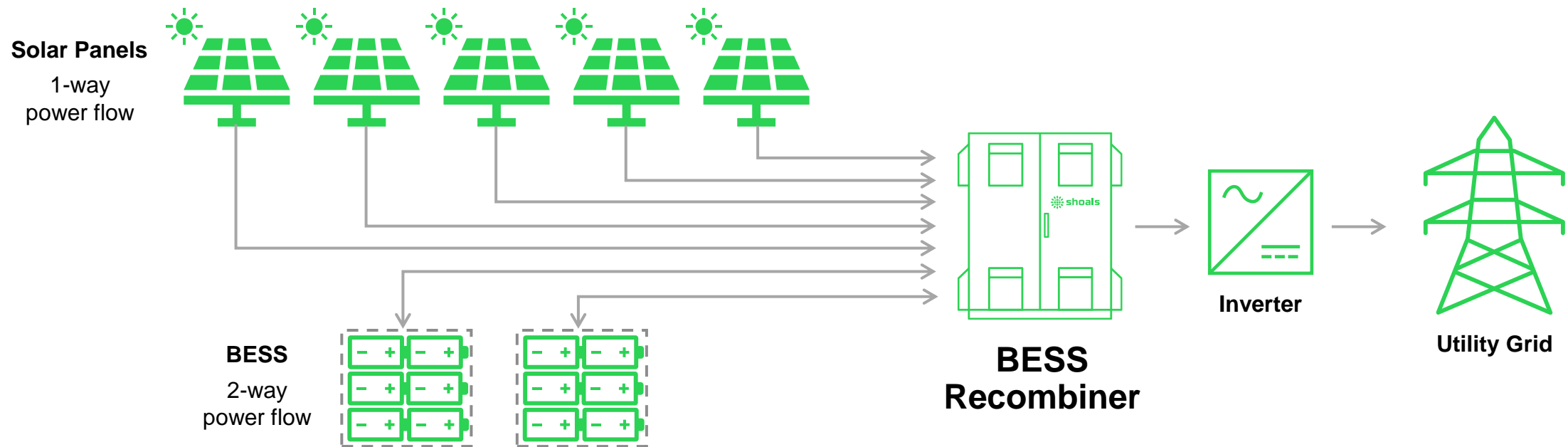

BESS Multi-Load Break Disconnect Switches

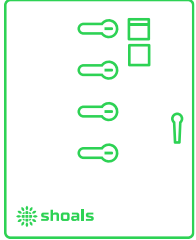

BESS Multi-Load Break Disconnect Switches are used to isolate and remove power from multiple BESS containers

- Allows centralized disconnect means away from BESS containers
- Reduces O&M time
- Improves efficiency, and faster installs
- Reduces footprint, gear and cable

Wall Mounted Enclosure



Floor Standing Enclosure



Exterior View



Interior View

Features

- 1500V DC
- Up to (16) independent 500A load break disconnects
- Available with fused or non-fused inputs
- Safety Shields over all live parts
- Padlockable Type 3R Wall Mounted and Free Standing Enclosures
- Wall Mounted Enclosure
 - ✓ up to (5) 400A or (4) 500A switches
- Free Standing Enclosure
 - ✓ up to (16) 400A or (16) 500A switches
- NRTL certified to UL1741

BESS – Example MLBD Layout

- Typically installed on the BESS system to isolate containers.
- MLBDs remove power from the battery module for service and maintenance.
- Provides centralized disconnect means.

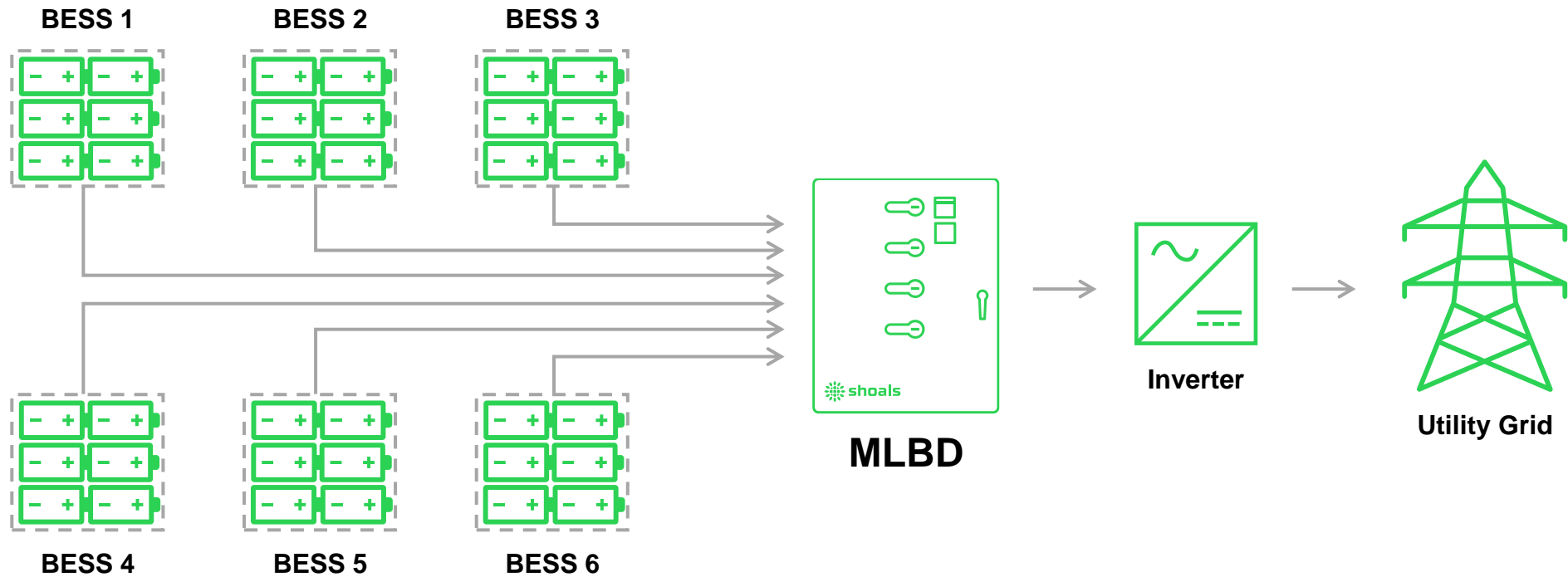

How to Optimize Your BESS and BESS + Solar Projects

Choose the right partner with BESS solutions and renewable energy expertise



Integrate BESS Solutions Early in Project Design

- Make BESS solutions a key component from the outset to ensure maximum standardization and reduce variability.
- Reach out to your trusted EBOS partner early for seamless integration of plug-and-play solutions in your project.



Leverage Shoals' Expertise for an Optimal Project Layout

- Submit your Single Line Diagrams for our review and recommendations
- Value-add design and engineering capabilities deliver optimized site layouts



Q&A

