

DOCKETED

Docket Number:	23-IEPR-01
Project Title:	General Scope
TN #:	249363
Document Title:	Clean Coalition Comments - Clean Coalition comments on 2023 IEPR Scoping Memo
Description:	N/A
Filer:	System
Organization:	Clean Coalition
Submitter Role:	Public
Submission Date:	3/17/2023 5:02:02 PM
Docketed Date:	3/20/2023

*Comment Received From: Clean Coalition
Submitted On: 3/17/2023
Docket Number: 23-IEPR-01*

Clean Coalition comments on 2023 IEPR Scoping Memo

Additional submitted attachment is included below.



17 March 2023

California Energy
Commission
715 P Street, Sacramento,
CA 9581
Via Electronic Filing

CEC Docket 23-IEPR-01: Clean Coalition Comments on 2023 Integrated Energy Policy Report Scoping Memo

Dear Chair Monahan, Vice Chair Gunda, California Energy Commission Members, and Staff,

The Clean Coalition is a nonprofit organization whose mission is to accelerate the transition to renewable energy and a modern grid through technical, policy, and project development expertise. The Clean Coalition drives policy innovation to remove barriers to procurement and interconnection of distributed energy resources (“DER”) — such as local renewables, demand response, and energy storage — and we establish market mechanisms that realize the full potential of integrating these solutions for optimized economic, environmental, and resilience benefits. The Clean Coalition also collaborates with utilities, municipalities, property owners, and other stakeholders to create near-term deployment opportunities that prove the unparalleled benefits of local renewables and other DER.

We appreciate the thoughtfulness put into the scoping memo and laud the Energy Commission’s focus on interconnection throughout the electrical system in the 2023 Integrated Energy Policy Report (IEPR). Addressing areas in the interconnection process where roadblocks currently exist as well as proactively solving future bottlenecks will significantly improve the procurement process by adding much needed certainty for organizations attempting to site new renewable energy projects. There is an unprecedented need for new capacity in California, mainly to ensure system reliability, but also to meet the rising demand for local resilience solutions (e.g., solar+storage, Solar Microgrids, and Community Microgrids). Distributed energy resources (DER) offer a broad range of benefits and a unique set of interconnection issues that need to be streamlined as compared to traditional utility-scale resources. We support the Energy Commission’s decision to focus on accelerating distribution grid interconnections separately from accelerating bulk grid interconnections; whereas the California Independent System Operator (CAISO) is facing a historically large interconnection queue now in Cluster 14, the influx of distribution-level interconnection applications is expected to occur over the next two decades as transportation and building infrastructure in the state is fully electrified.

Clean Coalition comments will focus on accelerating distribution grid interconnections, particularly the need to streamline the front-of-meter (FOM) interconnection process, via reform of the Wholesale Distribution Access Tariff (WDAT).

The greatest opportunity to improve the efficiency of the distribution-level procurement process is through streamlined WDAT interconnection.

Over the past decade, interconnection timelines (and costs) for projects deployed behind-the-meter (BTM) have been reduced markedly due to the California Public Utilities Commission’s (CPUC) Rule 21 interconnection proceeding (R. 17-07-007). However, due to the lack of CPUC-jurisdiction on the issue, the WDAT interconnection process has not received the same level of scrutiny and reform is long overdue. See the table below, which shows the differences in cost and the duration of the interconnection process for 1 megawatt (MW) projects applying for a BTM interconnection versus a WDAT Fast Track interconnection.

Factor	BTM 1 MW rooftop project	FOM 1 MW rooftop Fast Track project
Typical cost	\$37,500	\$312,450
Typical timeframe	302.5 business days	723 business days

The interconnection process for a typical FOM project costs more than eight times as much as the typical BTM project and will likely take more than twice as long as a BTM project. Reform is necessary to shorten the interconnection application review process and pre-construction timelines, eliminate late design surprises and cost increases, and make policy fixes to streamline FOM interconnection. Ideally, the lessons learned from years of streamlining the Rule 21 interconnection process can be applied to the WDAT process, along with other specific reforms that are codified in the 2023 IEPR. For example, consider the following six broad areas we have identified as crucial/need-to-reform opportunities to streamline WDAT interconnection.

1. FOM interconnection costs cannot be definitively determined prior to application from publicly available information.
2. FOM projects face significant delays during interconnection studies.
3. FOM interconnections are not allowed on NEM customer service line drops, adding substantial costs and complexity.
4. FOM project applicants do not have access to utility-approved Single Line Diagrams (SLDs) based on known configurations.
5. The deeding and escrow process—where the applicant funds infrastructure upgrades and then legally gifts the equipment to the utility to complete the interconnection process—often adds a substantial delay before permission to operate (PTO) is granted.
6. Duplicative information requested in both the interconnection and permitting process results in delays that could be avoided through automation.

Clean Coalition has considerable experience with the difficulties of the WDAT interconnection process. As part of the Peninsula Advanced Energy Community (PAEC) Initiative¹, the Clean Coalition team studied 209 FOM interconnection applications and found that 82% failed to secure permits or dropped

¹ As part of the PAEC Initiative, the Clean Coalition created a pilot for streamlining interconnection (see <https://clean-coalition.org/peninsula-advanced-energy-community/interconnection>)

out. The remaining 18% of applications that were approved took between 6 months and 2.25 years. In addition, we have firsthand experience navigating the WDAT interconnection process in PG&E’s service territory as part of a CEC-grant funded FOM battery energy storage project called the Valencia Gardens Energy Storage (VGES) project. The project, (see the SLD below), was intended to increase the hosting capacity on the feeder by 25% and potentially provide resilience down the line to the low-income senior housing at the Valencia Gardens Apartment in San Francisco where it was to be sited.

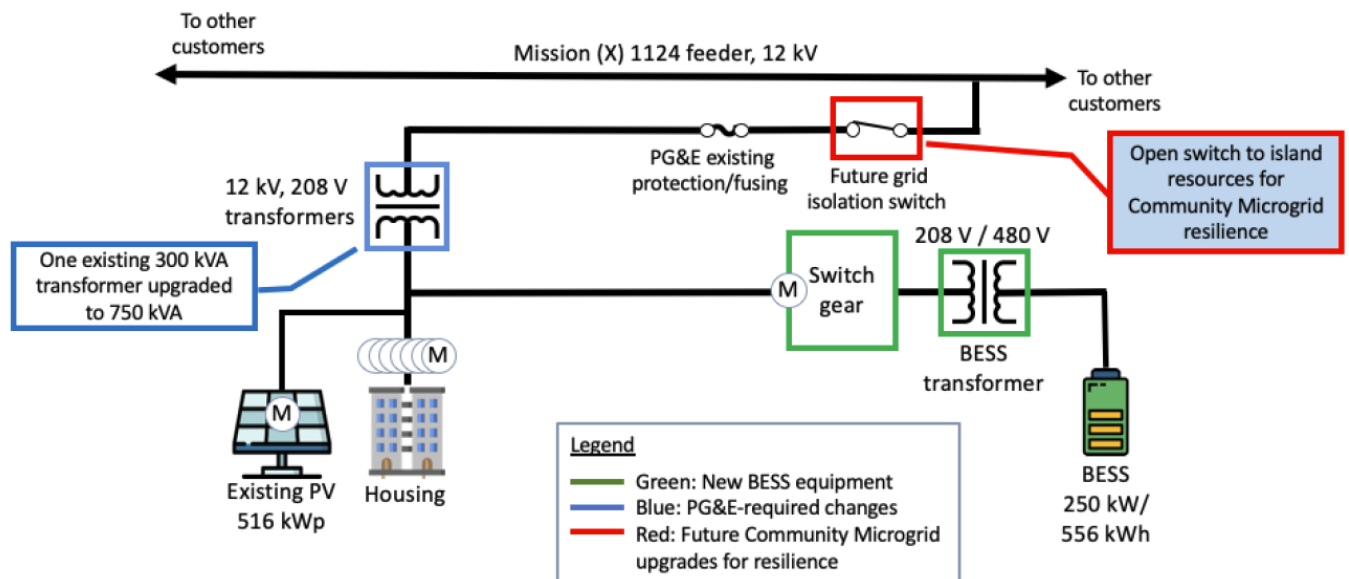

Future resilience opportunity to upgrade VGES into a Community Microgrid

The Fast Track process, which was expected to take approximately six-months ended up taking over two years due to in large part to utility delays and the project costs for interconnection-related upgrades ballooned from \$156,999 to \$460,887. Without sufficient information to make a fully informed decision, developers often choose to let languish in the interconnection queue rather than withdrawing an application, since withdrawing forfeits queue position and could lead to a much higher cost allocation for network upgrades by the time the application is re-submitted, which results in mounting costs for both the applicant and the utility. In the case of VGES, we expected to be able to pull permits at 6 months after submitting the Interconnection Application, with a point of budget certainty at 6.5 months. The actual process took over two years, with a point of budget certainty at 25 months. Late surprise requirements and cost increases added to this extended timeline; for example, PG&E added a cost of ownership (COO)—the cost for the utility to maintain and/or replace equipment as needed. The COO was not mentioned initially, and when it was brought up, the cost was underestimated. The graphic below shows an in-depth comparison of the expected timeline for a Fast Track interconnection versus the actual interconnection process that occurred. Note that the Small Generator Interconnection Agreement (SGIA) was signed at 10.5 months, yet new requirements for upgrades were added as far as 12 months after the SGIA was executed.

FOM Interconnection Application submittal to OK to pull permits was expected to take about six months.

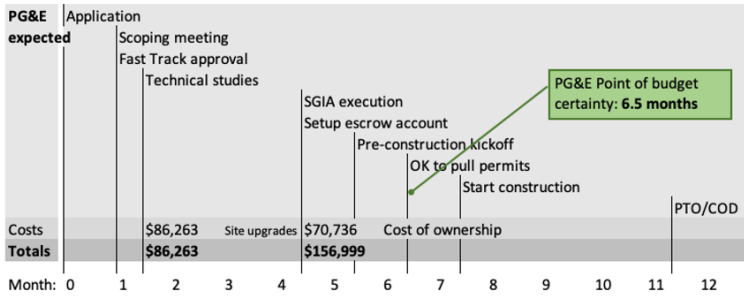

Late surprise cost increases

Instead, the process took over two years.

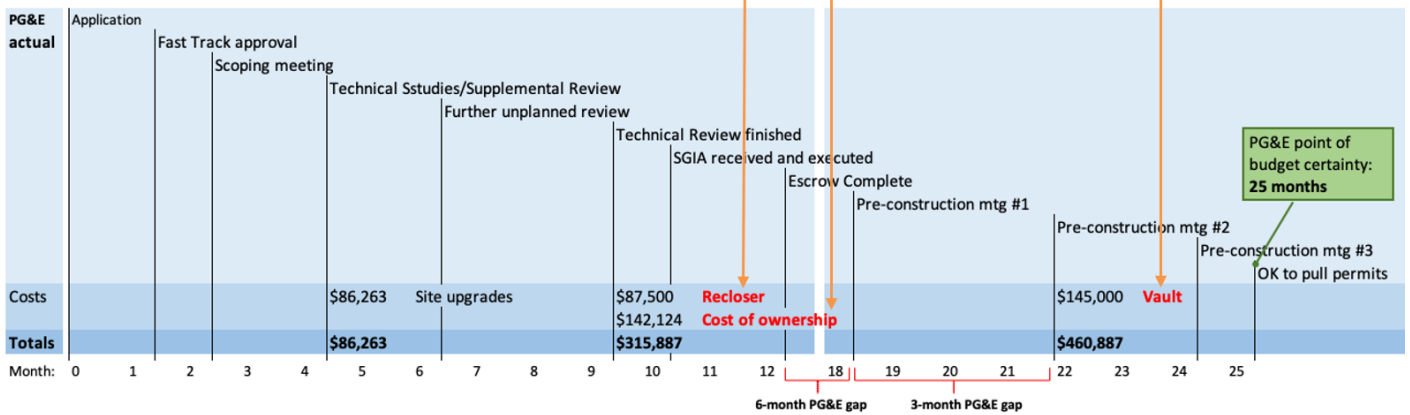

VGES - Expected Fast Track FOM Interconnection timeline vs. actual

The Clean Coalition urges the Energy Commission consider specific reform to streamline the different project sizes that are eligible for Fast Track WDAT interconnection, as well as general WDAT interconnection. Creating a determinative FOM interconnection process that reduces uncertainty for developers is key to unlocking the full value of a high DER future, including, but not limited to resilience and greater flexibility over local loads. For projects like VGES, that are on the smaller side of the WDAT Fast Track requirements, we propose a Fixed Fee, Utilities Pay system to streamline the process.

Details on the Clean Coalition’s Fixed Fee, Utility Pays (FixUP) Proposal:

- FixUP will allow FOM projects to determine whether they qualify for Fixed Fee interconnection based on publicly accessible eligibility criteria. The Fixed Fee is estimated at \$10,000.
- All FOM projects that are no larger than 1 MW will avoid the bureaucratically complex and unnecessary process of having to pay for grid upgrades and then legally deed those upgrades to the utility, as well as avoiding the need for an escrow account, which eliminates further complexities and costs.
- For FOM projects that are no larger than 1 MW and that do not meet all other Fixed Fee eligibility criteria, the utility will still directly pay for any interconnection costs to streamline the interconnection process for these small FOM projects and then recover those costs based on standardized unit costs, which each utility publishes annually.

- The Clean Coalition estimates that FixUP will yield an average of at least **\$25,000 in bureaucratic savings alone** per FOM project.

By adopting a standard fee for projects that meet certain deterministic criteria and ensuring that the utility pays for upgrades directly, FixUP would extend the streamlined BTM interconnection processes, timing, and price certainty to small FOM projects.

As noted above, streamlining non-Fast Track WDAT interconnection is also essential for ensuring that future Energy Commission or CPUC-sponsored DER programs are successful. In a Green Power Institute (GPI) report called *A Modern Cinderella Story: Assessing the state of California’s community-scale renewable energy market*, one of the key findings is that over the past 15 years, of the programs focused on wholesale distributed generation (WDG²)—see the table below—only an average of 28% of the contracted capacity has come online.³

	PG&E	SCE	SDG&E	Total
PURPA MW allocated	NA	NA	NA	NA
PURPA contracted 2007-2017	39.2	0	30	69.2
PURPA online 2007-2017	0	29.8	0	29.8
Online as % of allocated	NA	NA	NA	NA
PV PPA MW allocated	500	500	0	1000
PV PPA contracted	272.5	64.9	0	337.4
PV PPA online	199	56.9	0	255.9
Online as % of allocated	40%	11%	NA	26%
AB 1969 MW allocated	209.2	247.6	40.2	497
AB 1969 contracted	64.5	120.1	15	199.6
AB 1969 online	64.5	115.6	9.5	189.6
Online as % of allocated	31%	47%	24%	38%
ReMAT MW allocated	218.8	226	48.4	493.6
ReMAT contracted	31.9	48.4	12.5	92.8
ReMAT online	27.5	30.4	7.6	65.5
Online as % of allocated	13%	13%	16%	13%
BioMAT MW allocated	111	114.5	24.5	250
BioMAT contracted	19.8	6	3	28.8
BioMAT online	4.6	0	0	4.6
Online as % of allocated	4%	0%	0%	2%
RAM MW allocated	653	756	165	1574
RAM contracted	370.4	635.4	87.6	1093.4
RAM online	331.2	635.4	57.6	1024.2
Online as % of allocated	51%	84%	35%	65%
SB 43 MW allocated	272	269	59	600
SB 43 contracted	56.4	95	40	191.4
SB 43 online	52.75	60	20	132.75
Online as % of allocated	19%	22%	34%	22%
All seven programs MW online as % of MW allocated				28%

California’s major WDG programs over the past 15 years

² <https://clean-coalition.org/wholesale-distributed-generation/>

³ GPI, *A Modern Cinderella Story: Assessing the state of California’s community-scale renewable energy market*, V1.6 (Jan 2023), at p. 4

There are multiple reasons that California’s past WDG programs have been less-than-successful; developer attrition due to FOM interconnection issues (and a lack of codified program guidelines for streamlined interconnection) is a shared link amongst them all. The table below provides a non-exhaustive list of Clean Coalition recommendations to improve the WDAT interconnection process:

WDAT Interconnection Issues and Clean Coalition Solutions

Issue	Summary of issue	Solution
Delays caused by upgrade requirements	For some parts of the process, developers are currently unable to work directly with third parties to make utility upgrades; for any upgrades that the IOUs must make, developers must rely on the utility’s schedule, which leads to delays.	Approve a system like the Rule 21 interconnection process, which allows utility third-party vendors approved by the utility to carry out infrastructure upgrades. (All requirements, specifications, and inspections would still be in the hands of the utility.) Allowing pre-approved developers to work directly with third parties would address the need for upgrades in a timely manner while reducing total project costs.
Confidentiality rules limit developer/utility information sharing.	IOUs consider all project-specific information confidential — even though developers do not generally request confidential status.	Offer specific details on interconnection studies to provide important information for project managers, and to foster collaboration between developers throughout an IOU service territory. Redact information upon developer request (opt-out by default, opt-in by choice).
Prohibitive interconnection costs can make site selection in certain areas extremely difficult.	Current project economics make interconnection costs prohibitive.	Change the methodology for allocating network upgrade costs (for DER projects providing a public good) so costs can be recovered in a similar manner to transmission interconnection upgrades. Alternately, consider a cost sharing system that spreads out costs rather than forcing one developer to shoulder the full cost burden.
Changing estimates (surprise increases) for network upgrades causes developer uncertainty.	FOM interconnection costs cannot be definitively determined or even roughly estimated prior to application from publicly available information. FOM projects also face significant delays during interconnection impact and cost responsibility studies.	Implement a cumulative cost approach, ensure the applicant receives the final design & costs early, reduce timeline gaps between SGIA/financial security deposit phase to pre-construction/permit-ready status, shorten interconnection application review process and pre-construction timelines, & the utility to begin analysis early with all subject matter experts.

<p>Lack of access to accurate grid data causes developer uncertainty (part 1)</p>	<p>Grid upgrade costs are not transparent in advance and can often come as a surprise, meaning a developer has to submit an application just to determine whether the cost of moving forward is reasonable.</p>	<p>Provide greater access to actionable ICA data prior to submission of an IA, allowing developers to determine locations where grid upgrades are not necessary or which upgrades are most cost-effective. Add to ICA maps all projects and dates in the interconnection queue to accurately represent the feeders once the projects are interconnected. Ideally, forecasted load growth data will also be added to the maps.</p>
<p>Lack of access to accurate grid data causes developer uncertainty (part 2)</p>	<p>It is not possible to conduct a full economic analysis for a potential project without accurate inputs for utility costs that are in a user-friendly form (the data needs to be easy to work with/model).</p>	<p>Provide on-demand/online modeling to allow applicants to optimize system size and design relative to impact mitigation costs. In the future, add information about locationally relevant utility-sponsored programs that compensates projects for providing grid services (e.g., increasing hosting capacity, voltage regulation, etc...).</p>
<p>Lack of project management flexibility</p>	<p>Personnel changes, missed internal-utility deadlines, late additions of equipment upgrades, last-minute construction changes for major equipment, delayed project schedule, a delayed engineering costing, and lengthy timelines are enough to halt a project. Deadlines need to be met.</p>	<p>Tighten the project management process by:</p> <ul style="list-style-type: none"> • Holding bi-weekly interconnection application check-in calls from the beginning of the project with the interconnection manager assigned to the project that include all relevant parties as okayed by the customer of record. • Ensuring subject matter experts at the utility work in parallel. • Allowing the customer of record to invite all relevant parties to listen in to meetings. Typically, the utility will only speak to the customer of record or customer representative—often the subcontractor or engineering, procurement, construction (EPC).

New Rule 21 SLDs and configurations are needed to achieve climate goals and unlock a High DER future.

In the direct future, the total demand for energy in California is expected to rise as the state continues the process of decarbonizing the energy portfolio and the pace of electrification ramps up—both building and transportation electrification. In that scenario, which is one the state is preparing for and already seeing glimpses of now, the local load growth will be met in part by DER and changing customer energy usage patterns. The Energy Commission’s Title 24 standards already require that new constructions are built with energy efficiency measures and on-site renewable generation, ideally enough to make it a zero net energy (ZNE) facility. Clean Coalition believes that each of the investor-owned utilities (IOUs) should publish template SLDs for Title 24-compliant facilities to use in the design and planning stages as well as

to ensure that the interconnection process is as expeditious as possible.⁴ Interconnection applications will be easier for consumers (and developers) if there are pre-approved SLDs, resulting in fewer projects being rejected outright. However, utilities will retain the right to scrutinize and reject applications. Clean Coalition originally proposed this in the Rule 21 Interconnection proceeding, but the CPUC’s final decision concluded that it was not necessary at the time, given the low number of applications for ZNE facilities.⁵

■ = Included in the Microgrid Decision (D.20-06-017) ■ = Not explicitly included in the Microgrid Decision (D.20-06-017) ■ = Not Addressed in the Microgrid Decision (D.20-06-017)

ZNE resources may be configured under any of the following Rule 21 Tariff options:

NEM

- Single customer (Included in D.20-06-017) ■
- NEMA (aggregated) (Not specified - Included in D.20-06-017?) ■
- NEM-MT (multiple-tariff) (Not specified - Included in D.20-06-017?) ■
- VNEM (virtual) including SOMAH (multifamily) (Not specified - Included in D.20-06-017?) ■

NEM-PS (paired storage) alternatives as applicable: (Included in D.20-06-017) ■

- i. Battery only non-export (Not specified - Included in D.20-06-017?) ■
- ii. Battery no grid charging (Not specified - Included in D.20-06-017?) ■

Basic single customer (not NEM) ■

- Non-export (D.20-06-017 only addresses storage) ■
- Non-export & battery no grid charging (D.20-06-017 only addresses storage) ■
- Export (Not included in D.20-06-017) ■
 - i. Battery non-export (Not included D.20-06-017) ■
 - ii. Battery no grid charging (Not included in D.20-06-017) ■

Future variations

- Provision of grid services or energy sales outside of NEM ■
 - i. To host utility (Rule 21) (Not included in D.20-06-017) ■
 - ii. To wholesale aggregator, transactive or FERC regulated market (Not included in D.20-06-017 - applies to CCA procurement) ■

SLDs (that would be beneficial for ZNE facilities) at the time D. 20-09-035 was adopted⁶

The number of applicants for Title 24 facilities has increased since D. 20-09-035 and it will undoubtedly increase. The IEPR should specify that ZNE SLDs are necessary to ensure developers/ratepayers have sufficient resources at their disposal to properly follow the standards.

In addition to SLDs for ZNE facilities, the IEPR should consider the implications of FERC Order 2222, in terms of Rule 21 interconnections that want to participate as part of an aggregation or offer grid services (at the CASIO-level or future distribution-level markets). New configurations, standards, and guidelines will be necessary to truly enable the full range of values that DER can provide. Some examples include:

- Simultaneous discharging of solar+storage.

⁴ <https://clean-coalition.org/wp-content/uploads/2020/10/Clean-Coalition-R.17-07-007-Working-Group-4-Proposal-19d-03-bs-15-Oct-2020.pptx>

⁵ D. 20-09-035 <https://docs.cpuc.ca.gov/PublishedDocs/Published/G000/M347/K953/347953769.PDF>

⁶ Image from slide 8 of Clean Coalition’s 15 Oct 2020 Presentation to Working Group 4.

- FOM Energy storage deployed for time shifting to reduce peak demand or to increase hosting capacity.
- DER (such as energy storage or d-STATCOMs) deployed for distribution voltage regulation.
- Single facility microgrids (with multiple meters on the same continuous parcel).
- Allowing different off-takers than the individual that pays the energy bill for a facility (if approved by all parties involved).
- Interconnections based on operational-flexibility hosting capacity.

While Rule 21 is CPUC-jurisdictional, it is essential that the Energy Commission consider it to be a key area for improvement in the procurement process that should be highlighted in the 2023 IEPR.

Conclusion

Clean Coalition appreciates the opportunity to submit these comments on the IEPR Scoping Memo and looks forward to continuing the dialogue on interconnection reform.

/s/ BEN SCHWARTZ

Ben Schwartz
Policy Manager
Clean Coalition
1800 Garden Street
Santa Barbara, CA 93101
Phone: 626-232-7573
ben@clean-coalition.org

March 17, 2023

Valencia Gardens Energy Storage (VGES) Project (Draft Final)

Task 8.3: Front-of-Meter (FOM) Energy Storage Interconnection Case Study



Prepared for
California Energy Commission
1516 Ninth St., MS-51
Sacramento, CA 95814

Prepared by
Clean Coalition
1800 Garden Street
Santa Barbara, CA 93101
www.clean-coalition.org

May 2021

Table of contents

About the author	3
Legal disclaimer	3
Executive summary.....	4
Key challenges.....	5
Key findings.....	5
Proposed solution	6
Valencia Gardens Energy Storage (VGES) 2-BESS project details.....	7
Expected Fast Track Interconnection process compared to VGES 2-BESS experience	10
VGES 2017 – 2020: Detailed interconnection / pre-construction sequence of events.....	12
VGES 2017 – 2019: Key milestones, impacts, and costs.....	13
VGES 2-BESS FOM Fast Track Interconnection process: The reality	14
VGES 2020 – 2021: Issues encountered	14
VGES 2-BESS interconnection challenges and lessons learned	15
Solution: Pilot for Streamlining Fast Track FOM Energy Storage Interconnection	18
Moving forward: VGES 1-BESS project	18
Appendices	21
Appendix A: Pilot for Streamlining Fast Track FOM Energy Storage Interconnection	21
Appendix B: Barriers to FOM interconnection compared to BTM interconnection	29
Appendix C: Policy innovations to streamline FOM interconnection	32
Appendix D: Fixed Fee & Utility Pays (FixUP) proposal for small FOM interconnections	35
Appendix E: PG&E’s Wholesale Distribution Generation Interconnection Process for FOM projects ...	37
Appendix F: VGES interconnection review experience with PG&E	48
Appendix G: VGES interconnection estimated costs.....	51
Appendix H: VGES integration capacity analysis (ICA) data	52
Appendix I: VGES interconnection SLD from PG&E, showing PCC and POI	57
Appendix J: VGES economics forecast.....	58

About the author

The Clean Coalition is a nonprofit organization whose mission is to accelerate the transition to renewable energy and a modern grid through technical, policy, and project development expertise. The Clean Coalition drives policy innovation to remove barriers to procurement and interconnection of distributed energy resources (DER) such as local renewables, energy storage, and demand response. The Clean Coalition also establishes programs and market mechanisms that realize the full potential of integrating these solutions. In addition to being active in numerous proceedings before state and federal agencies throughout the United States, the Clean Coalition collaborates with utilities (and other load-serving entities) and municipalities (and other jurisdictions) to create near-term deployment opportunities that prove the technical and economic viability of local renewables and other DER.

Ultimately, the Clean Coalition envisions the United States being 100% powered by renewable energy, substantially from local sources. To make this goal a reality, the Clean Coalition is working to achieve the following objectives by 2020:

From 2025 onward, at least 80% of all electricity from newly added generation capacity in the United States will be from renewable energy sources.

From 2025 onward, at least 25% of all electricity from newly added generation capacity in the United States will be from local renewable energy sources. Locally generated electricity does not travel over the transmission grid to get from the location it is generated to where it is consumed.

By 2025, policies and programs are well established for ensuring successful fulfillment of the other two objectives.

Policies reflect the full value of local renewable energy.

Programs prove the superiority of local energy systems in terms of economics, environment, and resilience; and in terms of timeliness.

Visit us online at www.clean-coalition.org.

Legal disclaimer

This document was prepared as a result of work sponsored by the California Energy Commission. It does not necessarily represent the views of the Energy Commission, its employees, or the State of California. Neither the Commission, the State of California, nor the Commission's employees, contractors, nor subcontractors makes any warranty, express or implied, or assumes any legal liability for the information in this document; nor does any party represent that the use of this information will not infringe upon privately owned rights. This document has not been approved or disapproved by the Commission, nor has the Commission passed upon the accuracy of the information in this document.

Executive summary

The Clean Coalition is leading the Valencia Gardens Energy Storage (VGES) Project. This groundbreaking project, located at the Valencia Gardens Apartments, which houses hundreds of low-income families and senior citizens in the heart of San Francisco, will showcase how front-of-meter (FOM) energy storage can be effectively deployed in dense, developed urban environments.

Key project features

- The first FOM merchant energy storage project in California.
- Will deploy innovative energy storage that provides a replicable model for providing grid benefits exactly where they are needed most.
- Sited at the Valencia Gardens Apartments (VGA), a 300,000-square-foot low-income and senior housing facility with 260 units in San Francisco's Mission District.
- Designed to increase the solar hosting capacity of the distribution feeder by at least 25%. The site has existing solar of 516 kWdc on a feeder with a total of 580 kW of solar, exceeding the feeder peak load of 570 kW, so the feeder is currently at full capacity for hosting solar.
- Will examine how energy storage can be monetized by CAISO wholesale markets.
- Staged to provide indefinite renewables-driven backup power to critical loads at the VGA and potentially other facilities on the feeder.

By demonstrating how targeted deployment of energy storage can increase the grid's ability to handle greater amounts of distributed solar, yielding substantial grid and ratepayer benefits, VGES will set the stage for increased deployment of clean local energy in California and beyond.

Project benefits

The VGES Project will demonstrate how targeted deployment of energy storage can increase the grid's ability to handle greater amounts of distributed solar, yielding substantial grid and ratepayer benefits, and will set the stage for California to bring more distributed solar online. Project benefits include, but are not limited to, the following:

- **Hosting capacity (grant focus):** Designed to enhance the interconnection hosting capacity of the existing feeder by more than 25% and ensure far more solar can be sited on that feeder.
- **Merchant storage:** VGES will be the first FOM merchant energy storage project in the California market, demonstrating merchant energy storage market opportunity to drive deployment and reduce costs to ratepayers without ratepayer/utility capital investment or contract liability (demonstrates viability to both the supplier and the procurement markets).
- **Grid services benefits:** VGES will quantify the ability to provide potential services at the PG&E distribution and CAISO system levels (and potentially at the customer level through utility grid).
- **Regulatory advancement/policy benefits:** (1) Interconnection streamlining for energy storage; (2) energy storage deployment and distribution application value — hosting capacity, distribution investment deferral/grid needs assessment mitigation; and (3) potential distribution grid services.
- **Utility business model:** Identifying and quantifying distribution-level utility customer services enabled by energy storage.
- **Resilience:** Staging for resilience for a potential Phase II of VGES or other projects.
- **Supporting the Redwood Coast Airport Microgrid (RCAM):** Sharing Clean Coalition energy storage findings, lessons learned, and best practices to help guide RCAM with their project.

Key challenges

The VGES FOM Energy Storage project experienced multiple delays and other challenges that were detrimental to the progress of the project, key among these being the following:

- **Time:** It took **two years** from the inception of the Fast Track Interconnection process to completion of the pre-construction phase, when permits could be pulled.
 - **Lengthy interconnection process:** The Fast Track Interconnection process took over 12 months to complete and to move into pre-construction, as opposed to less than 6 months, as PG&E had originally indicated. This caused serious problems with the project schedule.
 - **Delays with PG&E engineering estimates and construction drawing:** It then took 12 months from SGIA execution to receiving engineering estimates, construction drawing, and project schedule, which prohibited the EPC from pulling required permits.
 - **PG&E IA delays:** PG&E failed to meet some tariff deadlines for interconnection review and issued notices of delay, in addition to taking the maximum allowed time at most other opportunities. This impacted the timeline and created more uncertainty.
 - **Lack of PG&E personnel resources:** Lack of personnel availability and changes of key PG&E personnel, such as the Interconnection Manager and Service Planner, also slowed the project's progress.
 - **No room for equipment lead times:** PG&E's delays during both the IA process and the pre-construction phase made it virtually impossible to maintain a project schedule, including meeting long lead times for critical equipment.
- **Cost:** Project costs increased throughout the process from the expected **\$156,999** to **\$460,887**.
 - **Cumulative cost increases:** Unexpected cost increases seriously impacted the project's budget, making the project difficult to move forward and complete.
 - **Inflexibility with discretionary upgrades:** PG&E provided no flexibility with discretionary upgrade equipment. Given the lengthy Interconnection Application (IA) process and delays, there was insufficient time to find workaround solutions such as a potential recloser solution (for example, an IEEE certified hardware limiter).
 - **Last-minute construction design changes:** PG&E changed the transformer location and required the installation of an underground vault, increasing the project cost by \$145,000 after the executed Small Generator Interconnection Agreement (SGIA) and after the pre-construction site walk, adding the requirement for a transformer vault to be added in the public right-of-way.
- **Uncertainty:** Uncertainties stemmed from PG&E personnel changes, missed internal deadlines, late equipment upgrade requirements, last-minute construction changes for major equipment, delayed project schedule and engineering costing, and lengthy timelines.

Key findings

Economic findings

The Clean Coalition is engaged in the VGES Project to evaluate the ability of FOM energy storage to support increased grid hosting capacity for solar generation, while participating in wholesale markets to earn revenues to reduce the cost of grid upgrades that would otherwise be required to allow high levels

of solar penetration. In the current pre-construction phase, we have modeled operational requirements and resulting revenue projections in advance of deployment and actual market participation.

The good news is that the operational profiles required of the battery to mitigate the impact of high levels of solar penetration are very well aligned with optimized profiles for revenue generation. This means that energy storage can support increased levels of solar on already saturated circuits, reducing the need for grid upgrades while simultaneously providing energy and potential grid services, including supporting local resilience in the event of regional power outages (see [Appendix J, VGES economics forecast](#)).

Policy findings

- The Fast Track Interconnection process for FOM projects needs to be streamlined to provide transparency and consistency. As part of the Peninsula Advanced Energy Community (PAEC) Initiative, the Clean Coalition team studied 209 applications for FOM (also known as wholesale distributed generation, or WDG) interconnection approval and found that 82% failed to secure permits or dropped out. The 18% of applications that were approved took 6 months to 2.25 years. As part of the PAEC Initiative, the Clean Coalition created a pilot for streamlining interconnection (see <https://clean-coalition.org/peninsula-advanced-energy-community/interconnection>).
- The single most important policy innovation to streamline FOM interconnection would be a fixed fee for qualifying projects, as well as requiring the utility to pay directly for interconnection costs. These enhancements would extend the streamlined behind-the-meter (BTM) interconnection processes, timing, and price certainty to small FOM projects.
- Greater access to Integration Capacity Analysis (ICA) data prior to submitting an interconnection application would allow developers to determine locations where grid upgrades are not necessary or which upgrades are most cost-effective.

Proposed solution

The proposed solution that the Clean Coalition identified for the issues encountered during the VGES Project is a **Pilot for Streamlining Fast Track FOM Energy Storage Interconnection**.

The proposed pilot (see [Appendix A](#)) will shorten the interconnection application review process and pre-construction timelines while at the same time decreasing costing and design review inefficiencies, by employing modifications to the current Fast Track Interconnection process for FOM projects.

The enhanced interconnection process will allow early discovery and resolution of issues, which should reduce the time to pull permits from over two years to just under six months. This early discovery of upgrade and design-based issues will allow the applicant time to find cost-effective solutions.

Valencia Gardens Energy Storage (VGES) 2-BESS project details

The VGES Project is staged to become the first front-of meter (FOM) merchant energy storage system without utility offtake in California. This groundbreaking project, located at the Valencia Gardens Apartments (VGA), which houses hundreds of low-income families and senior citizens in the heart of San Francisco, will showcase how FOM energy storage can be effectively deployed in dense, developed urban environments. The VGES Project, which originally planned to deploy two 548 kWh battery energy storage systems (BESS) and has been modified to deploy one 556 kWh BESS, will provide a replicable model for providing grid benefits exactly where they are needed most. The project is designed to increase the solar hosting capacity of the distribution feeder by at least 25%, allowing more solar to be sited along the feeder; the solar-loaded VGA has existing solar of 516 kWdc on a feeder with a total of 580 kW of solar, exceeding the feeder peak load of 570 kW. The VGES project includes quantifying the technical and economic benefits of deploying energy storage on distribution feeders that are nearing capacity for hosting solar — unless local energy storage is added to time-shift solar for simultaneously optimizing grid operations and ratepayer economics.

Project feeder maps

The feeder map below shows the project site, on the Mission (X) 1124 Feeder from the San Fran X (Mission) substation.

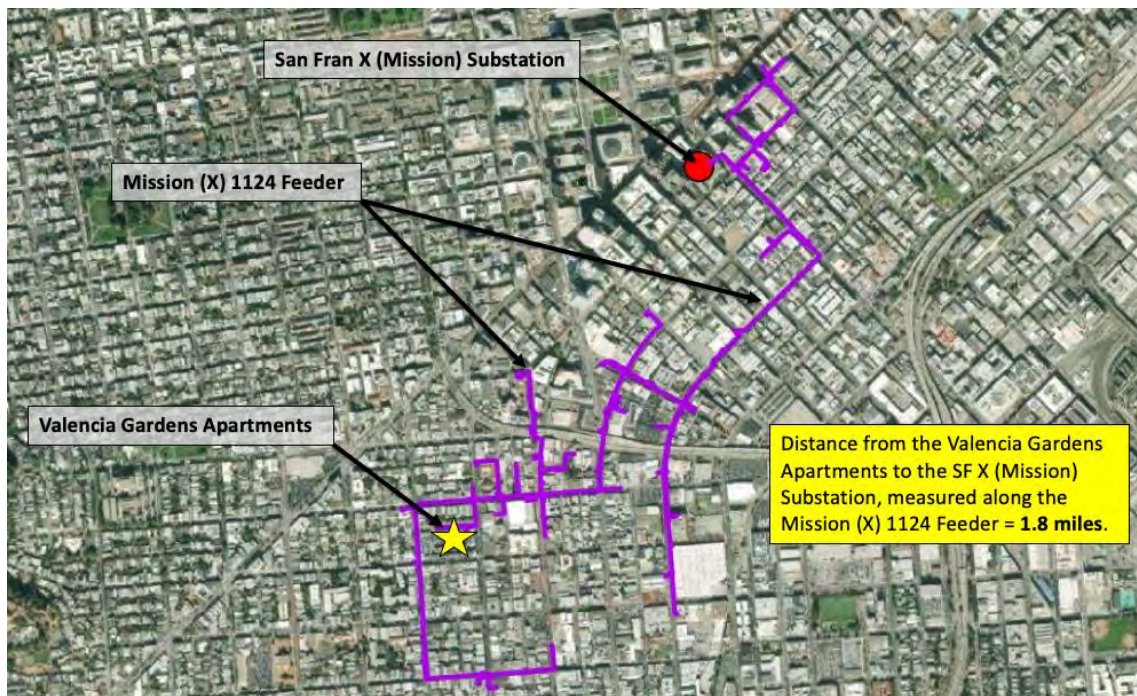

The following feeder map from PG&E also shows the Mission (X) 1124 Feeder from the San Fran X (Mission) substation. The feeder lines are colored according to their available capacity for adding solar, with green indicating more available capacity for adding solar onto the feeder and red indicating a higher probability of needing feeder upgrades for adding solar projects.



Project site overview

The site overview below shows the locations of the two battery energy storage systems (BESS) that were planned for the 2-BESS project (yellow squares), each at capacities of 250 kW / 548 kilowatt-hours (kWh). The VGES Project has a total capacity of 500 kW / 1096 kWh. Peak load on the circuit is 570 kW; solar capacity on the circuit is 580 kW. The dashed red line indicates the conduit connecting the two systems. The existing 516 kW of solar can be seen scattered among the various housing project rooftops. The 12 kilovolt (kV) circuit feeder for the property is shown in purple.



Simplified single-line diagram showing future resilience potential

The schematic below shows the future resilience opportunity to create a Community Microgrid at the VGA complex, by adding a grid isolation switch that can be activated in the event of a grid outage and using the solar+storage to maintain electrical power for the residents and the office.

Energy storage for the VGES Project will be sized for Community Microgrid operations that can provide indefinite solar-driven backup power to the most critical loads during grid outages of any duration. Additionally, PG&E’s Community Enablement Microgrid Program (CEMP) looks to be a potential fit for a potential Community Microgrid follow-on phase.

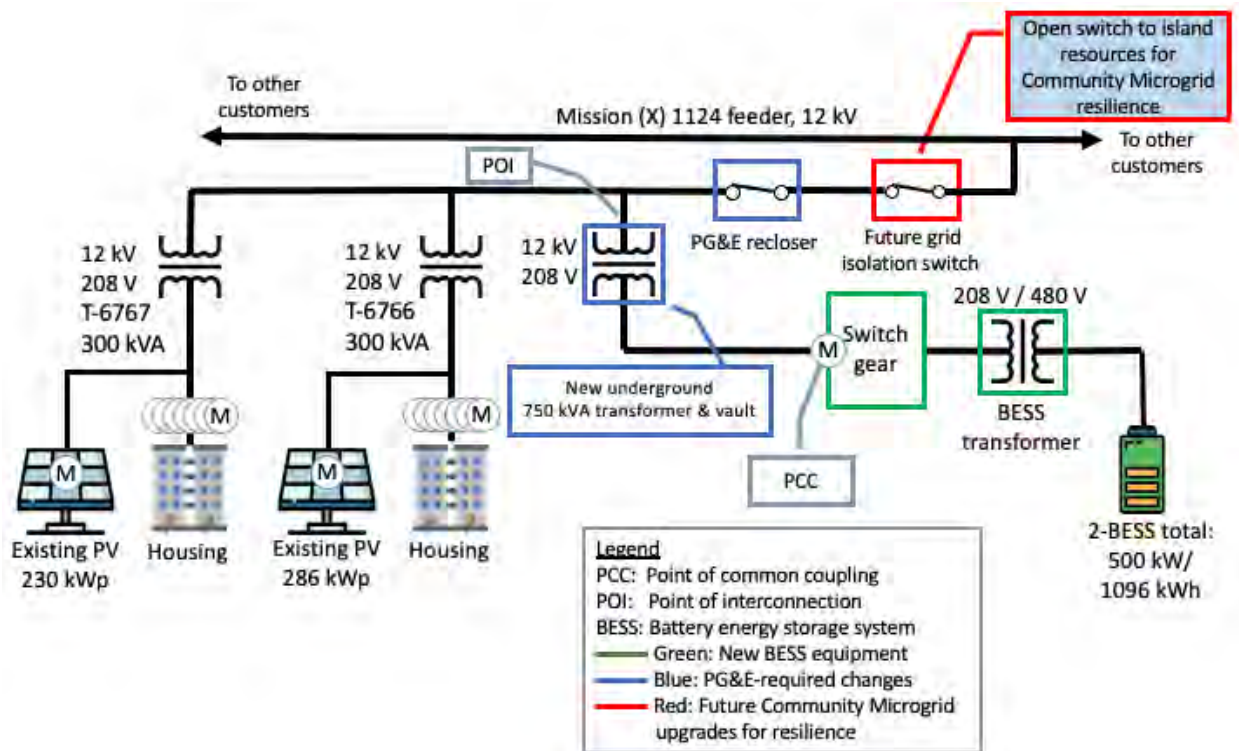

Expected Fast Track Interconnection process compared to VGES 2-BESS experience

The Fast Track Interconnection process is for smaller facilities of up to 5 megawatts (MW) that will have minimal impact on PG&E's electric system. Project proposals are accepted by PG&E throughout the year on a rolling basis. The table below lists the total capacity, including voltage and location conditions, necessary to qualify for the Fast Track Interconnection process. The VGES project, fed from a 12 kV feeder with a total capacity of 500 kW and located 1.8 miles from the substation, falls in the orange zone below.

Total capacity, voltage, and location conditions to qualify for Fast Track Interconnection process

Fast Track line voltage	Fast Track capacity eligibility regardless of location	Fast Track eligibility on a mainline and ≤ 2.5 electrical circuit miles from substation
< 5 kV	≤ 500 kW	≤ 500 kW
≥ 5 kV and < 15 kV	≤ 2 MW	≤ 3 MW
≥ 15 kV and < 30 kV	≤ 3 MW	≤ 4 MW
≥ 30 kV and < 60 kV	≤ 4 MW	≤ 5 MW

The interconnection customer can determine this information about a proposed interconnection location in advance by requesting a pre-application report pursuant to Section 1.2 of PG&E's Wholesale Distribution Tariff (WD)T.

Expected Fast Track Interconnection process under PG&E's Wholesale Distribution Generation Interconnection Process



- **Application processing:** Requires site plan, single-line diagram (SLD), site control documents, and application fee.
- **Scoping meeting:** Held to secure agreement on point of interconnection and generator size; PG&E to advise if Fast Track approval is granted.
- **Technical studies/Supplemental Review:** Analyzes impact of generation on PG&E's electrical system. Shows needed capital improvements to PG&E's electrical system and initial cost estimates to ensure safety and reliability of the grid. Distribution upgrades to be triggered by generator.
- **Interconnection Agreement (IA):** To be executed.
- **Project implementation:** Construction planning meetings, refined cost estimates, final engineering drawings.

See [Appendix E](#) for more details on PG&E's Wholesale Distribution Generation Interconnection Process.

Expected timing: According to PG&E, the Fast Track Interconnection study process typically takes about three months and consists of 10 screens. If the Fast Track screens determine that a project does not meet the requirements for the process, an additional independent or cluster study will be required before the project can interconnect.

Reality: The FOM Interconnection Application (IA) submission for VGES was successfully transmitted to PG&E on 3 December 2017. Since that date, the VGES Project has faced multiple challenges and delays in PG&E’s interconnection review process. These challenges resulted in a longer application completion process than was expected, as detailed below.

From the FOM Interconnection Application submittal to being able to pull permits was anticipated to take about six months:

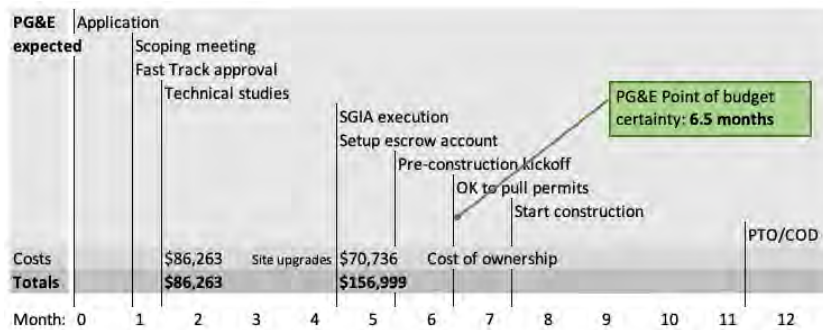

Instead, the process took **over two years:**

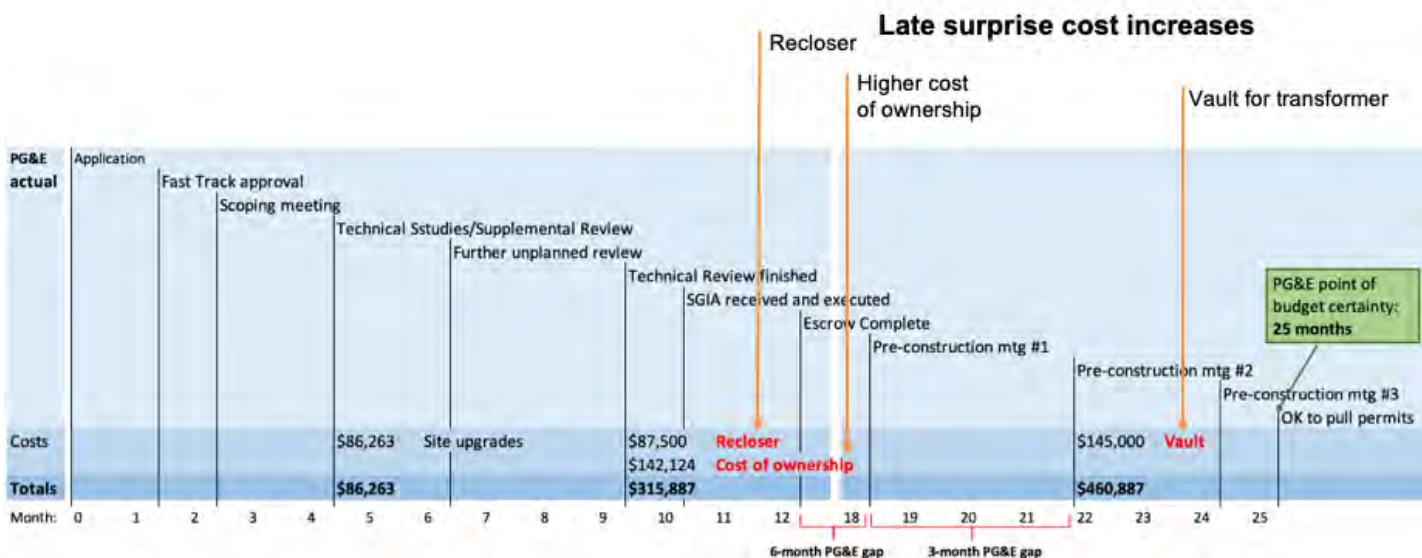

The following sections detail the sequence of events and the issues encountered to date during various phases of the VGES Project.

VGES 2017 – 2020: Detailed interconnection / pre-construction sequence of events

The following is the sequence of events experienced from the project kickoff and application submittal through the attempt to pull permits.

Activity	Completion date	PG&E step	# calendar months from IA submittal	Cost estimates	Critical impacts
CEC technical kickoff meeting	10/13/17	App submittal			
PG&E Interconnection Application (IA) submitted	12/3/17		0.0		
PG&E Interconnection Application deemed complete (Fast Track approval)	1/24/18	Scoping Review	1.7		Fast Track approval
VGES enters into Supplemental Review stage	2/20/18	Supplemental Review start	2.6		Supplemental review triggered — over 1MW
PG&E notifies EPC that the PG&E Interconnection Manager on the VGES project is being changed	3/22/18				
DELAY notification received from PG&E; Supplemental Review delay due to fires	4/11/18		4.2		
Supplemental Review update; initial PG&E Facilities Services Equipment estimates = \$86,263	4/25/18		4.7	\$86,263	
Supplemental Review update, PG&E is now assessing whether SCADA recloser is required	5/31/18	Second Supplemental	5.9		SCADA recloser assessment
PG&E completes Supplemental Review; deems SCADA recloser is required due to ESS maximum export + PV potential maximum export over 1 MW; WAIVER REQUEST SUBMITTED; SGIA negotiations continue	6/21/18		6.6		
SGIA received. Waiver request denied. PG&E Interconnection Manager advises not to sign SGIA, as it still needs to be reviewed/approved internally by PG&E upper management; new SGIA cost = \$173,763 (recloser: \$87,500; PG&E Facilities Services Equipment: \$86,263) + cost of ownership of \$142,123.82. Total SGIA cost = \$315,886.82	9/21/18	Second Supplemental Review completed	9.6	\$315,887	SGIA equipment costs + cost of ownership
Subcontractor receives SGIA approved by PG&E management	10/11/18		10.3		
SGIA executed by subcontractor	10/26/18	SGIA executed	10.8		SGIA executed
PG&E Credit Risk and subcontractor's bank, East West Bank, perform escrow account due diligence	10/31/2018 thru 11/8/2018				
PG&E Credit Risk continues to perform due diligence; subcontractor confirms funds are ready to transfer once escrow account has been setup	11/15/18		11.4		
Escrow Agreement executed, but account setup still pending due to East West Bank not being in PG&E Credit Risk's database	11/26/18		11.8		
PG&E Escrow process completed - funds transferred into account	12/14/18	Escrow account set: funded	12.4		PG&E SGIA/escrow process completed
PG&E onsite construction kickoff meeting held (PG&E Field Construction Management and Engineering attend)	6/19/19	Pre-construction meeting #1	18.5		
PG&E engineering cost estimates due, but delayed due to PSPS events	8/8/19		20.2		
Receive approved engineering drawing from PG&E (no vault)	9/20/19		21.6		
PG&E onsite pre-construction meeting held with PG&E newly assigned Service Planner; PG&E identifies need for underground vault due to access and safety issues	10/4/19	Pre-construction meeting #2	22.0	Total PG&E upgrade costs = \$316k+ \$145k (vault); Grand total = \$461k	Vault requirement
PG&E cost estimates due, but delayed due to PSPS and wildfires	10/31/19		22.9		
Approved PG&E engineering sketch received with vault inserted; final sketch reflects the secondary transformer location in underground vault out into the public right-of-way	11/18/19		23.5		
PG&E cost estimates received	11/22/19		23.7		
Third PG&E onsite construction meeting held with newly assigned PG&E Service Planner/Inspector confirms that vault is still required due to PG&E's access, safety, reliability requirements. PG&E inspector okays EPC to pull permits.	12/14/19	Pre-construction meeting #3: Okay to pull permits	24.4		
Attempt to pull permits. SF Planning discovers need for Conditional Use Authorization (CUA)	1/23/20		25.7		CUA required due to Planned Unit Development (PUD) restrictions

VGES 2017 – 2019: Key milestones, impacts, and costs

As the following table highlights, unexpected requirements from PG&E adversely impacted the project schedule and budget.

Date	Key milestones and impacts	Costs
12/3/2017	Interconnection Application submitted	
1/24/2018	Fast Track approval granted	
4/25/2018	PG&E utility upgrade estimate; NO MENTION OF RECLOSER	\$86,263
6/21/2018	PG&E engineering now determines the need for a SCADA recloser vs existing fusing; EPC asks to have decision reviewed by PG&E management; waiver submitted	
9/10/2018	Recloser waiver denied. SGIA being finalized	
9/21/2018	SGIA received with costing: PG&E utility upgrade estimate Recloser estimate PG&E total upgrade costs PG&E cost of ownership New total PG&E says not to execute, as internal management review is still needed	\$86,263+ <u>\$87,500</u> \$173,763+ <u>\$142,124</u> \$315,887
10/11/2018	SGIA received by subcontractor	
10/26/2018	SGIA executed by subcontractor	
12/14/2018	PG&E SGIA/escrow process completed (+12 months)	
	6-MONTH DELAY: ASSIGNING PG&E KEY PROJECT PERSONNEL AND SCHEDULING PRE-CONSTRUCTION	
6/16/2019	PG&E pre-construction meeting #1 held; NO MENTION OF VAULT REQUIREMENT	
	3-MONTH DELAY: PG&E ENGINEERING COSTING AND ENGINEERING DRAWINGS	
9/20/2019	PG&E-approved engineering drawing received; NO MENTION OF VAULT REQUIREMENT	
10/4/2019	PG&E pre-construction meeting #2 held: PG&E now identifies need for an underground vault New project upgrade cost with vault ELEVATED TO PG&E SENIOR MANAGEMENT	<u>\$145,000</u> \$460,887
11/18/2019	ELEVATION UNSUCCESSFUL: Underground vault REQUIRED; engineering drawings received	
12/14/2019	PG&E New Service Planner/Inspector requests pre-construction meeting #3; okay to pull permits	

VGES 2-BESS FOM Fast Track Interconnection process: The reality

The following graphics compare the expected process to the unexpected timelines and costs associated with the VGES FOM Fast Track Interconnection process from December 2017 (IA Application submittal) to December 2019 (okay to pull permits).

Expected VGES Fast Track Interconnection process: ~ 6 months and final cost in range of \$75k – \$100k

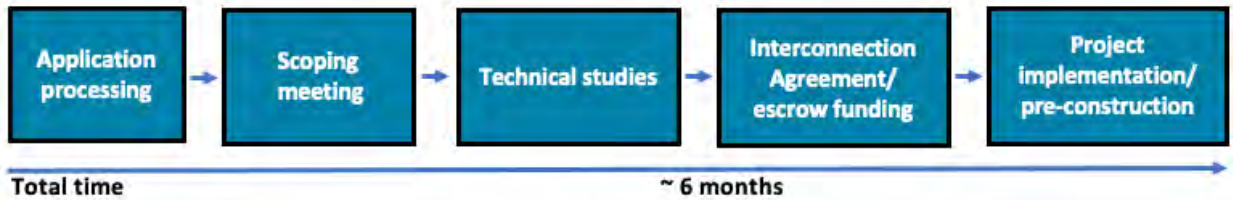

Actual VGES Fast Track Interconnection process: 25 months and final cost near \$461k

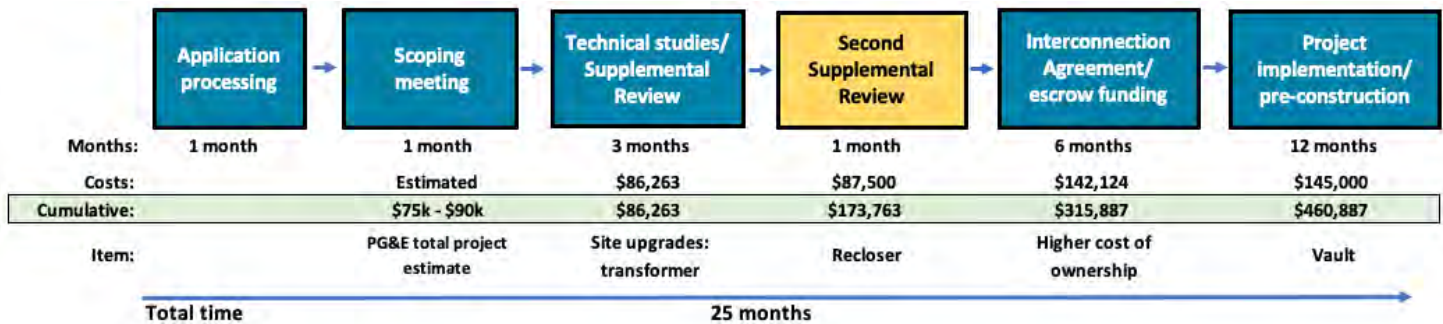

VGES 2020 – 2021: Issues encountered

The following are the primary issues that arose in in the 2020-2021 timeframe for the VGES 2-BESS project:

- Permit issues (San Francisco Planning Commission approval required):
 - San Francisco Planning Commission required the VGES subcontractor to obtain a conditional use authorization (CUA) for equipment enclosure size limitations.
 - Discovered on 1/24/2020. Planning Commission Hearing occurred on 10/15/2020.
- The pandemic resulted in project delays.
- The project encountered financial and budget constraints due to unexpected PG&E upgrade costs.
- The California Energy Commission (CEC) required a budget amendment and project schedule revisions.
- The CEC required a No-Cost Term Extension and budget amendment.
- The CEC required a project downsizing analysis.
- **PG&E REQUIRED SGIA WITHDRAWAL on 2/12/2021.**
- **SGIA WAS WITHDRAWN on 2/26/2021.** New IA for the downsized project will be submitted (date TBD).

VGES 2-BESS interconnection challenges and lessons learned

The VGES 2-BESS project experienced multiple delays and other challenges that were detrimental to the progress of the project — and that highlight areas for improvement of the FOM interconnection process:

- **Lengthy IA process:** The Fast Track Interconnection process, from application submittal through project implementation/pre-construction, **took 12 months as opposed to less than 6 months, as PG&E had indicated.** This caused serious problems with the project schedule and with equipment lead times.
- **Cumulative cost increases:** These unexpected cost increases seriously impacted the project's budget, making it difficult to move forward and complete the project.
- **Inflexibility with discretionary upgrades:** PG&E showed no flexibility with discretionary upgrade equipment and provided insufficient time to find workaround solutions. PG&E's inability to accept operational profiles or controls to mitigate potential grid impacts led to the need to upgrade the grid with a recloser. The recloser was **discretionary** for the project, but PG&E ultimately required it despite the fact that the project's intended operation will never exceed 1 MW. An IEEE certified hardware limiter could have provided a resolution.
- **IA delays:** PG&E failed to meet some tariff deadlines for interconnection review and issued notices of delay, in addition to taking the maximum allowed time at most other opportunities. This impacted the timeline and created more uncertainty.
- **Lack of PG&E resources:** Lack of personnel availability and change of key PG&E personnel, such as the Interconnection Manager and Service Planner, slowed the project's progress.
- **Equipment lead times:** PG&E's delays during both the IA process and the pre-construction phase made it virtually impossible to meet long lead times for critical equipment — for example, for the energy storage system and the switchgear
- **Last-minute construction design changes:** PG&E changed the transformer location and required the installation of an underground vault, increasing the project cost by \$145,000 after the executed SGIA and after the pre-construction site walk, and adding the requirement for a transformer vault to be added in the public right-of-way.
- **PG&E engineering and construction drawing delays:** After the SGIA execution, the project experienced 12 months of delay in receiving engineering estimates, construction drawing, and a project schedule. This prohibited the EPC from pulling the required permits.

Improvements needed to Fast Track Interconnection process for FOM energy storage

The FOM Energy Storage Interconnection process needs to be streamlined to reduce costs, timelines, and uncertainty for project developers. Currently, roughly 80% of FOM projects studied failed to secure permits or dropped out. Enhancements are required to create higher levels of accountability, transparency, communication, and consistency around timelines, costing, and design.

The major California utilities have indicated they were improving timeline setting, communication, and adherence, and that anecdotes by parties might relate to past practices but did not pertain to the current situation. With respect to the upgrade timelines, PG&E noted that it agrees on specific timelines with the customer for each project, and that these timelines are included in interconnection agreements and discussed and updated with the customer throughout the project life cycle. PG&E indicated it had been working on service planning improvements for the past several years, and the utility has set up a dedicated

centralized work group to handle all generation interconnection requests — an expected improvement because not all region-based cost estimators are very familiar with generation interconnections.

However, the VGES Project experienced frequent and major delays, from 1) PG&E failing to meet timelines and rescheduling dates and 2) lengthy and poorly coordinated practices, as steps were passed from one staff member to another both within and between various utility departments.

Lessons learned

Areas for improvement: PG&E

Issue	Details
Delays	Excessive delays between application submittal and SGIA execution / escrow account funding added 12 months to the project timeline. During the implementation phase, it took 12 months to receive PG&E construction drawing, which was required in order to pull permits. Minimizing delays would lower costs and improve project outcomes.
Cost overruns	Cumulative costing approach led to unexpected cost increases from \$156,999 to \$460,887; this approach must be changed to ensure successful projects.
Uncertainty	The current FOM Energy Storage Interconnection application process creates uncertainty for the developer, which adversely affects project outcomes.
Lack of project management flexibility — need more customer focus	<p>Project management needs to be tightened:</p> <ul style="list-style-type: none"> • This should include holding bi-weekly IA check-in calls from the beginning of the project with the interconnection manager assigned to the project, including all relevant parties as okayed by the customer of record. • Subject matter experts at PG&E should work in parallel. • PG&E will only speak to the customer of record or customer representative (typically the subcontractor/EPC); however, the customer of record should be allowed to invite all relevant parties to listen in.

Areas for improvement: Project developer

Issue	Details
Lack of comprehensive grid and site information	Gathering all grid and site information at beginning of project would 1) preempt unexpected issues and 2) design the project to mitigate constraints. Data and information needed includes ICA and other map data, HOA or Planned Unit Development (PUD) restrictions, Pre-Application Reports, Unit Cost Guide, customer data, rules and resources posted on utility interconnection websites.
Lack of understanding of key checkpoints between SGIA Execution and PG&E final construction drawings	Project developer needs to understand these key checkpoints and work to be proactive to line them up for effective project execution.
Multiple PG&E “Notice” delays	Although PG&E “Notice” delays should be minimized, it’s a good idea to plan for an additional two to four weeks of IA delays.
Lengthy project developer/ EPC review cycle times	Review cycle times on the part of the subcontractor/EPC should be minimized; having timeframes, costs, and all relevant data in advance will help with this.
For CEC grant-funded projects: Project representative selection	Serious thought should be given to who is listed as project representative and who is therefore allowed to communicate directly with PG&E, which only allows one person to be listed as the project representative when the IA is filed.

Areas for improvement: Policy

Issue	Details
Uncertainty in FOM interconnection costs and timeframes	FOM interconnection costs cannot be definitively determined or even roughly estimated prior to application from publicly available information. FOM projects also face significant delays during interconnection impact and cost responsibility studies. Policy innovations are needed to reduce these uncertainties, including third-party contractor approval to work on utility upgrades.
Lack of market opportunities	VGES economics were adversely affected by the lack of flexibility in access to markets — including for FOM DER to provide grid services, as well as to participate in potential CAISO markets. Increased market opportunities would enable interconnection costs to more easily be absorbed.
Lack of a regulatory forum to address the issues above	There is no CPUC forum for FOM interconnection. While such a forum is needed, it’s also important to ensure utility buy-in for FOM interconnection process improvements, even before taking the issues to a CPUC forum.

Solution: Pilot for Streamlining Fast Track FOM Energy Storage Interconnection

The proposed pilot (see [Appendix A](#)) will shorten the interconnection application review process and pre-construction timelines while at the same time decrease costing and design review inefficiencies by employing:

- **A more complete application package**
 - The interconnection applicant will be required to submit a more complete package, ready for detailed analysis.
- **Scoping review merged into technical analysis and mandatory field meeting**
 - This step allows for early exploration of alternative solutions to PG&E discretionary thresholds.
 - Requiring all the relevant PG&E departments to meet early with the applicant to review both technical and construction issues, and to begin early resolution of any potential issues that have been uncovered, will prevent issues from arising later in the process.
- **Final design and costing locked in early**
 - The financial burden of changes (cost and/or design) that are made after the technical analysis and mandated field meeting is placed on PG&E.
- **Reduced costs** for interconnection facilities upgrades and design changes
- **Shortened timeline gap** between SGIA/financial security deposit phase to pre-construction/permit-ready status

Moving forward: VGES 1-BESS project

Moving forward, to reduce project complexity, the VGES Project will deploy one BESS rather than two. The western BESS site will be eliminated, cutting the energy storage capacity roughly in half. This will eliminate PG&E's requirements for a vault for the upsized transformer, as well as for a new recloser.

As the project moves forward with the new subcontractor, Q CELLS, the proposed pilot can be applied to the 1-BESS project.

The following image shows the 1-BESS site layout, with only the eastern site remaining. The one remaining BESS will be sized at 250 kW / 556 kWh. With this smaller project, no vault is needed — the new transformer will be placed on the existing site pad. In addition, no recloser is needed. These factors will cut both the schedule and the costs for the project.

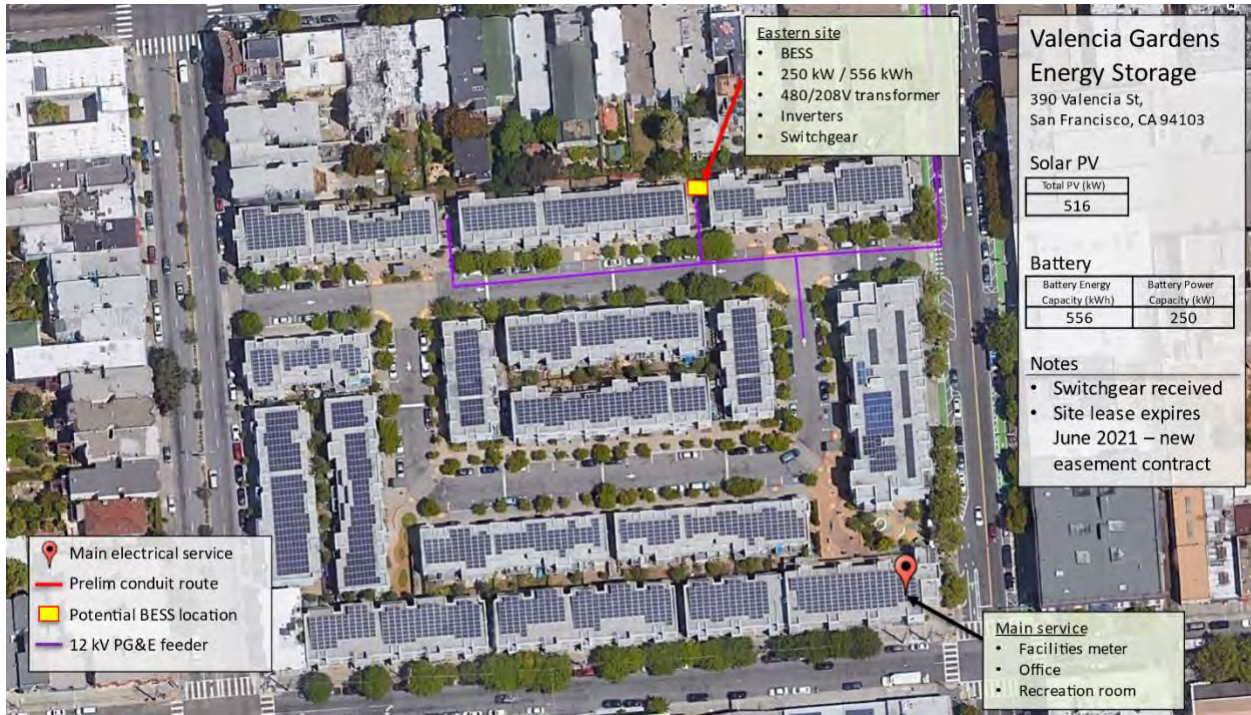

As shown in the following future microgrid schematic, the 1-BESS project is similar to the 2-BESS project but does not require a recloser or a vault. Like the 2-BESS project, the 1-BESS project sets the stage for a potential Community Microgrid at the VGA complex — which can be created by adding a grid isolation switch that can be activated in the event of a grid outage, and using the solar+storage to maintain electrical power for the office and other critical loads.

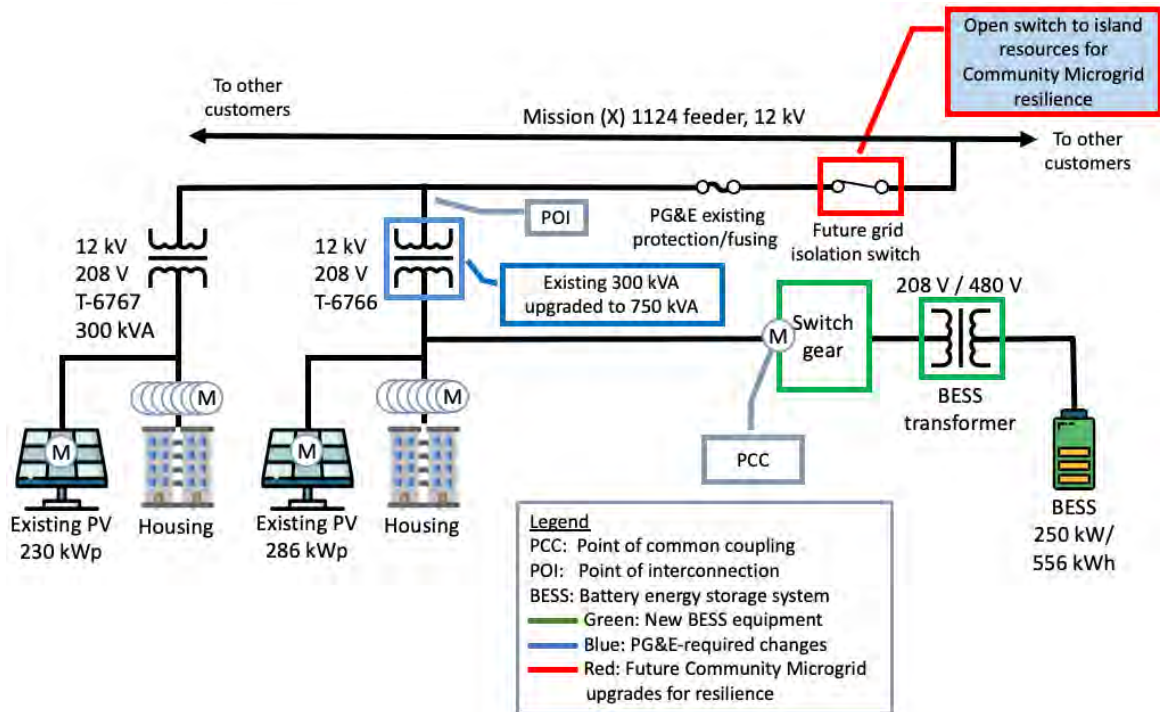

The Pilot for Streamlining Fast Track FOM Energy Storage interconnection can be applied to the 1-BESS project, as shown in the timelines below.

The first timeline shows the standard anticipated 1-BESS schedule based on our 2-BESS experience. At a bit over 18 months, the 1-BESS project is anticipated to go more quickly than the 2-BESS project, which took over 2 years. That’s because of the reduced size, which means we can remove some steps that PG&E required for the 2-BESS project: the additional supplemental review, which resulted in the recloser requirement, and the late design change requiring the underground vault. **However, the process is still too lengthy.**

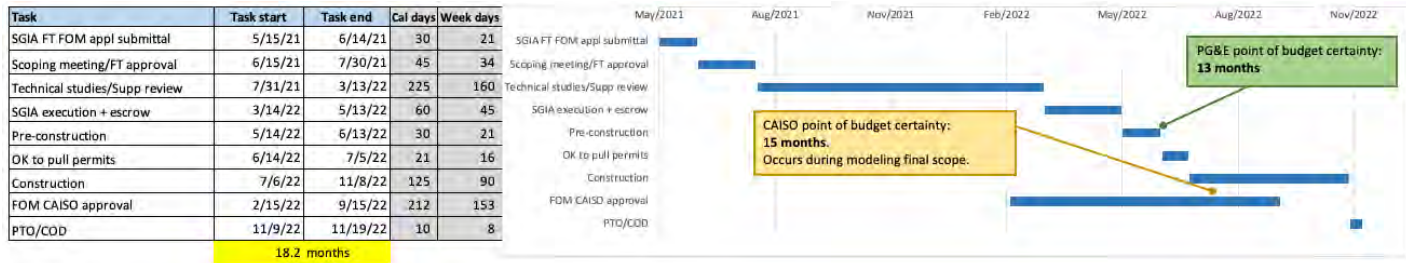

In contrast, this timeline shows a modified schedule based on our proposed pilot, which will shave off about 7 months. Key to the shorter pilot schedule is the early mandated field meeting and design signoff.

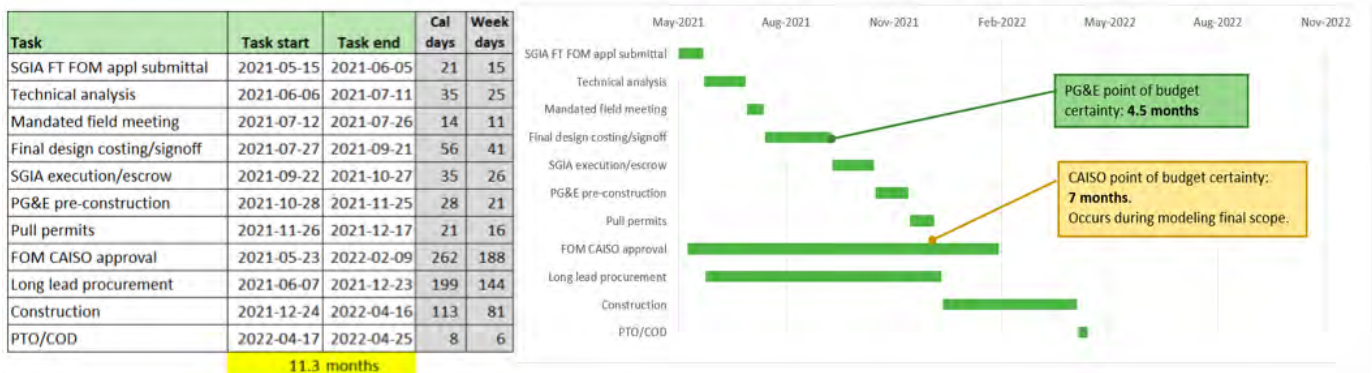

The next timeline shows the 1-BESS schedule from Q CELLS, the new subcontractor for the VGES Project. This schedule is a couple months shorter than the standard anticipated 1-BESS schedule, but it can still be streamlined. The Q CELLS 1-BESS schedule does not factor in time between escrow and finishing pre-construction with PG&E; before pulling permits, the developer must receive final pre-construction site walk signoff and the final engineering costing and construction drawing from PG&E. For the 2-BESS project, this took over a year, but the pilot’s mandated field meeting and earlier design & costing signoff will shorten that timeframe to less than two months.

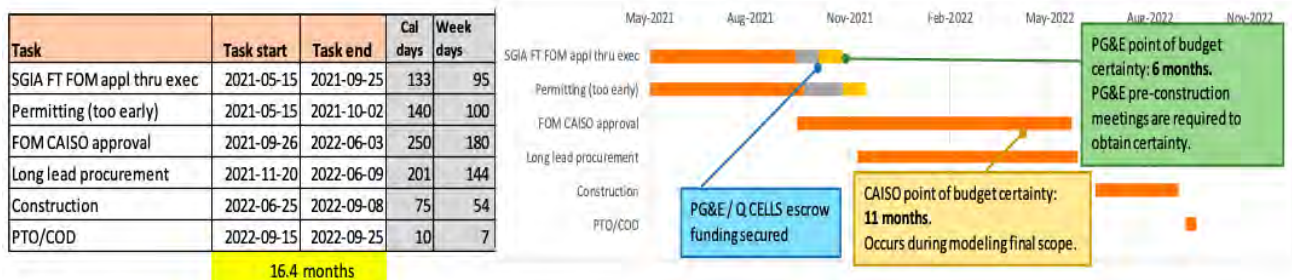

Appendices

Appendix A: Pilot for Streamlining Fast Track FOM Energy Storage Interconnection

Challenges the pilot will address

The VGES Project experienced frequent and major delays both from PG&E’s missed timelines and rescheduling dates, and from lengthy and timelines with lack of coordination, as steps were passed from one staff member to another both within and between various utility departments. As mentioned previously in this case study, these inefficiencies at PG&E caused the VGES Project to take over two years to go from application to permit-ready, with project upgrades and design changes that kept increasing with each new round of studies — resulting in increased project costs and insufficient time for the developer to find cost-effective solutions.

The key challenges noted previously in the case study are:

- **Time:** It took two years from the inception of the Fast Track Interconnection process to completion of the pre-construction phase, when permits could be pulled.
- **Cost:** The cumulative costs continued increasing throughout this time period, growing from the expected \$156,999 to \$460,887.
- **Uncertainty:** Uncertainties around PG&E personnel, equipment upgrades, construction requirements, costing, project schedule, and timelines prevented the project from moving forward as expected.

The following image summarizes the VGES 2-BESS experience with the Fast Track Interconnection process.

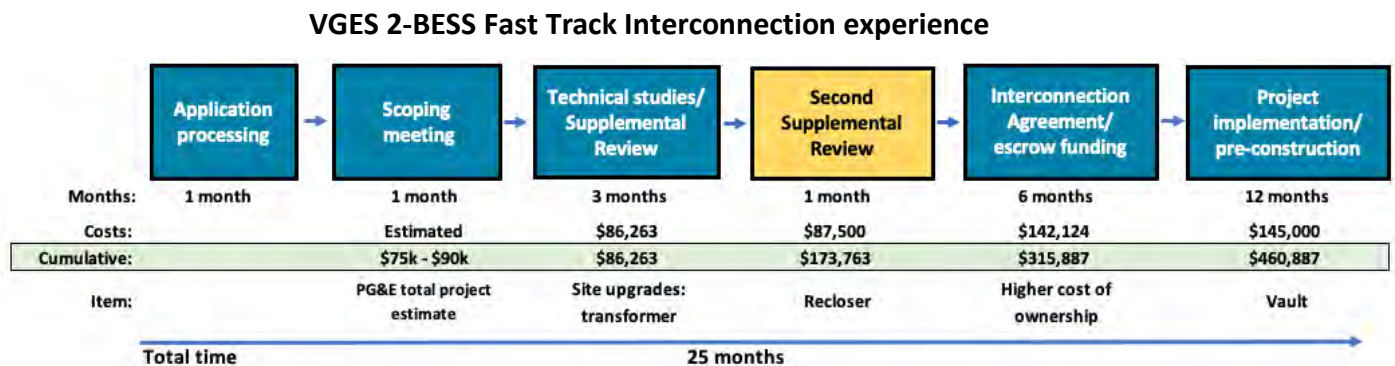

The Fast Track Interconnection process, from application submittal through project implementation/pre-construction, should have taken 6 months. However, the part of the process that went through the interconnection agreement/escrow funding phase took over 12 months to complete and to move into pre-construction, causing serious problems with the project schedule and equipment lead times. From escrow funding to the time that permits could be pulled with PG&E approval (the project implementation/pre-construction phase) took an additional 12 months. These delays, coupled with those resulting from the pandemic and a lack of transparency, delayed progress on VGES significantly. Costs

were also an issue. The expected interconnection and construction-related costs went up from approximately \$100k to over \$460k.

At the second pre-construction meeting, a field planner joined the team and assessed that the new transformer could not fit on the existing pad, so a requirement for a transformer vault was added. Quotes for this requirement added yet another \$145,000 to the project costs, which grew from the original \$155,000 to \$461,000 over a period of 95 weeks (almost 22 months). And yet, a third pre-construction meeting was required in week 105 before the OK to pull permits was given.

Pilot goals

The proposed pilot will:

- Shorten the interconnection application review process and pre-construction timelines.
- Lower costs by decreasing inefficiencies in costing and design review.

Core pilot components

To achieve these goals, the pilot will employ:

- **A more complete application package from the customer of record** (including proposed POI, PCC, site generation size)
 - The interconnection applicant will be required to submit a more complete package, ready for detailed analysis.
- **Scoping review merged into technical analysis and mandatory field meeting**
 - This step allows for early exploration of alternative solutions to PG&E discretionary thresholds.
 - Requiring all the relevant PG&E departments to meet early with the applicant to review both technical and construction issues, and to begin early resolution of any potential issues that have been uncovered, will prevent issues from arising later in the process.
- **Final design and costing locked in early**
 - The financial burden of changes (cost and/or design) that are made after the technical analysis and mandated field meeting is placed on PG&E.
- **Reduced costs** for interconnection facilities upgrades and design changes
- **Shortened timeline gap** between SGIA/financial security deposit phase to pre-construction/permit-ready status

Accelerating the application process to finish in six months depends upon the following elements, which require the applicant to provide more actionable information upfront. This enhanced application will allow PG&E to bring the process area experts together early in the sequence to analyze the site needs and constraints, ensuring that potential issues are uncovered early in the process and giving the applicant time to resolve them in a cost-effective manner.

Participant eligibility

- Interconnection applicant projects will be eligible to participate in the pilot and will be guaranteed Fast Track status throughout the application process if they meet these requirements:
 - Are no larger than 1 MWac (if at 1MWac or larger, use of hardware/software limiting solutions is to be considered).
 - Are able to interconnect at locations where no significant grid upgrades are required (as determined by engineering analysis and field meeting).

Enhanced application package

- The application package must include the SLD, site plans, site control docs, generator size, and proposed POI & PCC.
- This completeness allows all the reviewers to apply their varying expertise to assess all of the potential issues or needed changes early in the review process, rather than waiting for more input to be received from the applicant over a longer period of time.

Technical analysis prior to field meeting (received by applicant minimum of 5 days prior to field meeting)

- Analyze impact of generation on PG&E's electrical system. Show needed capital improvements to PG&E's electrical system and initial cost estimates to ensure safety and reliability of the grid. Distribution upgrades to be triggered by generator.

Mandated field meeting with PG&E service planning, interconnection, engineering, field inspector, and project developer

- This site meeting is required to complete the physical site inspection, design review, and interconnection review, and determine any necessary adjustments that may be required on the utility grid.
- Combining the expertise of the reviewers early in the process reduces the uncertainty that plagued the VGES Project. This mandated meeting ensures that all the reviewers have combined their expertise in a timely and effective manner.

Signoff on design and costs

- No additional design or costing reviews will be allowed after signoff. Any design and or costing changes after this point are to be paid for by PG&E.
- If the proper review and assessment energy is expended early in the process, there should be no surprises later.

Execute SGIA/financial security deposit posting

- Thirty days should be sufficient time to finish processing the Interconnection Application after the design and costs are signed off.
- It should take less than two weeks to post the security deposit.

Pre-construction phase

- PG&E to host a pre-construction site meeting.
- PG&E's construction sketch is **required** to be shared at this meeting. Any design and/or costing changes from the SGIA are to be paid for by PG&E.

PG&E construction drawing

- PG&E is to furnish the construction drawing, allowing the project developer to pull permits.

OK to pull permits

- Applicant can begin construction.

Timeline of pilot components

Starting week from application	Weeks to complete	FOM Interconnection Process steps	Notes, deliverables, and impacts
0	3	Application submittal and review	Enhanced application package for Fast Track Interconnection must include SLD, site plans, site control docs, generator size, and proposed POI & PCC; reviewer to determine if Fast Track status can be approved prior to technical analysis.
3	4	Technical analysis	Enhanced application package on file; Fast Track status granted. Analyze impact of proposed system and determine needed upgrades to discuss at mandatory field meeting.
7	1	Customer review and comment	Customer checks for surprises and gets a first look at possible issues or significant costs.
8	2	Mandatory field meeting	Verify facility upgrade requirements and obtain all information needed to finalize design, costing, protection, and schedule.
10	4	Final design and costing	Deliver to customer.
14	2	Customer review and comment	Comments, questions, resolution of issues.
16	2	Signoff on design and costs between PG&E and customer	Changes after signoff are responsibility of PG&E; design and costing flow into SGIA.
18	2	Prepare SGIA	Obtain PG&E management approvals.
20	1	Execute SGIA	Sign SGIA contract.
21	2	Set up and fund escrow account	Work with PG&E's credit risk department, EGI, and post security deposit.
23	3	Pre-construction starts	PG&E to host pre-construction meeting; construction sketch is required at meeting; any design and/or costing changes are to be paid by PG&E
26	1	Final construction drawings to customer	OK to pull permits.

Anticipated pilot outcomes

The pilot is projected to reduce project costs and timelines, while giving the project developer more certainty and control during the Interconnection Application process. By finalizing the design early in the process, proposed projects can reduce discretionary upgrade costs and equipment design changes that directly increase project costs. As an example, the VGES 2-BESS project required upgrades that increased costs (including the cost of ownership), with project costs totaling **\$461,000**. The primary upgrades that PG&E required for the 2-BESS project were a vault and a recloser. These could have been avoided as follows.

Resolution for vault requirement:

- A mandated field meeting would have uncovered safety and access requirements related to a new transformer being placed next to the existing site transformer.
- This would have allowed time to find an alternate location for a transformer pad by working with the site host. Thus, the vault would not have been required.

Resolution for recloser requirement:

- Early technical analysis would have uncovered the discretionary recloser threshold level of over 1 MW, allowing ample time to pursue an IEEE-certified hardware limiter solution after PG&E rejected a software limiter solution on the BESS.
- Solar and BESS normal operation would never be at maximum export at the same time (solar would max at noon, and BESS would max during the evening peak).
- The hardware fix would have served as a backup solution.

The VGES 2-BESS experience illustrates how these factors affected the timeline and cost:

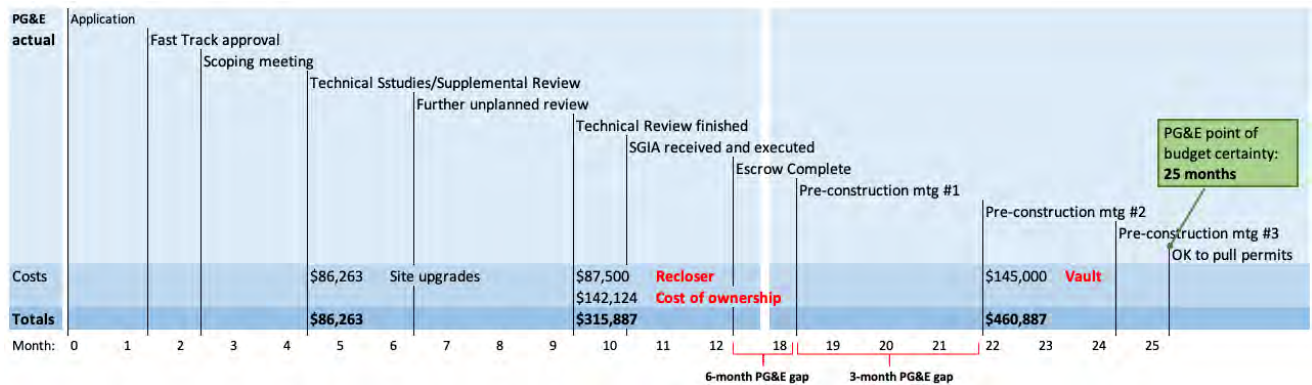

In contrast, our proposed pilot would significantly shorten the schedule and lower the costs, also making costs more predictable. Based on our VGES experience, the pilot could save about 19 months from application to pulling permits, with the point of budget certainty about 8 months earlier:

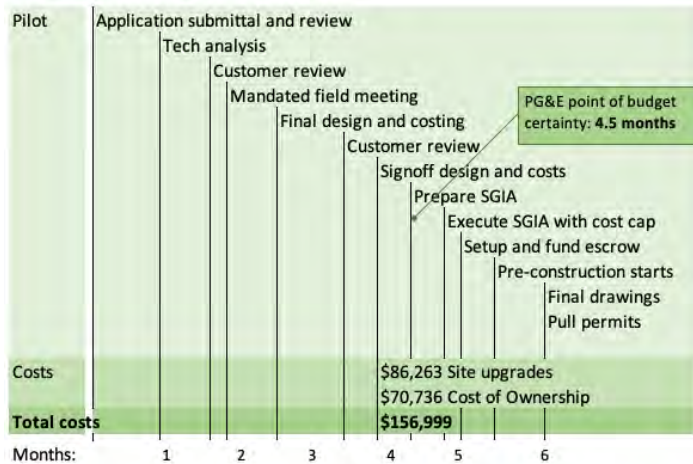

The following image summarizes the proposed pilot changes; green boxes represent changes or additions to the existing FOM Fast Track Interconnection Process.

Proposed FOM pilot with VGES 2-BESS project as an example

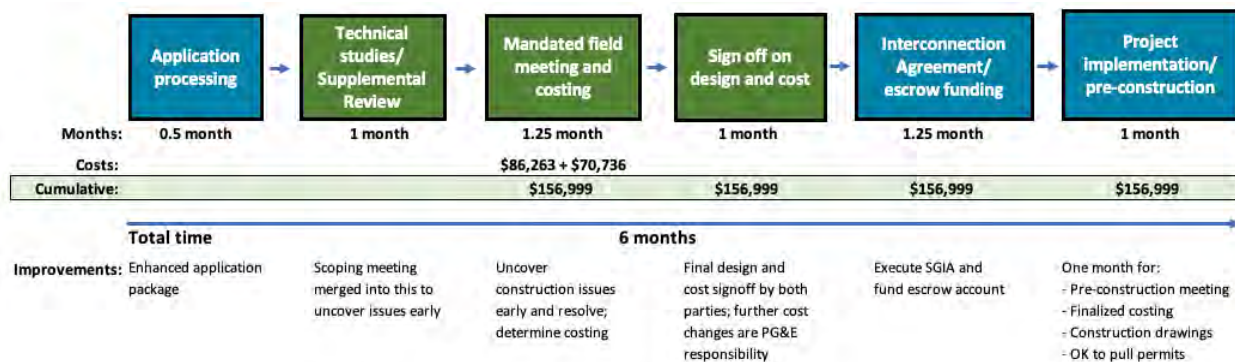

The following table highlights gaps and surprises encountered during the VGES Project, as well as the core pilot components needed for a streamlined FOM interconnection process.

Timeline and process comparison of FOM Pilot vs VGES experience

FOM pilot			VGES FOM experience		
Weeks to complete from application	FOM Interconnection process steps	Notes and impacts	Weeks to complete from application	FOM Interconnection Process steps	Notes and impacts
0-2	Application submittal and review, Fast Track approval	Enhanced application package must include SLD, site plans, site control docs, generator size, proposed POI & PCC	0	Application submittal	New application submitted
3-6	Technical analysis done	Review application package, analyze needed system improvements and upgrades	7	Scoping Meeting	Reviewed POI and generator size; rough cost estimate provided
7-13	Mandated field meeting	Verify facility upgrades requirements, obtain all information needed to finalize design and costing	20-28	Technical studies / Supplemental Review	Impacts identified and analyzed; site upgrades disclosed; no initial mention of recloser or cost of ownership
14-15	Sign off on design and capped costs	Changes after signoff are responsibility of PG&E; design and costing flow into SGIA	} Reduce uncertainty by mandating budget cap		
17-18	Execute SGIA	Sign SGIA contract	44	SGIA received	Cost of recloser and cost of ownership now added to facility upgrade costs
18-21	Execute SGIA, Financial Security Deposit	Post security deposit	51-53	PG&E SGIA/escrow process completed	Executed SGIA and posted security deposit
21-24	Pre-construction starts	PG&E to host; construction sketch is required at meeting Any design and or costing changes are to be paid for by PG&E	80	PG&E pre-construction kickoff meeting held	No mention of vault
} 6 months of churn could have been prevented by early discovery and resolution from initial mandated field meeting			93	PG&E-approved engineering drawing received	No mention of vault
			95	PG&E pre-construction meeting #2 held	PG&E now identifies need for an underground vault
			95-102	Escalation of challenge to vault requirement fails	Revised engineering drawings received
25-26	Final construction drawings to customer	Needed to pull permits	105	Final construction drawings to customer/final pre-construction meeting	New Service Planner/ Inspector requests one last field meeting. Drawings received; okay to pull permits.

Reference materials for pilot

PAEC pilot report

An earlier report on this topic was submitted in 2018 for the Peninsula Advanced Energy Community (PAEC) project, another CEC grant project. That report can be found at:

https://clean-coalition.org/wp-content/uploads/2019/01/PAEC-Task-4.4-Final-Design-of-Pilot-for-Testing-Streamlined-Interconnection-Procedures-23_wb-27-Dec-2017-1.pdf

BTM vs FOM estimated costs

The typical cost for FOM projects is **more than eight times** the cost for similarly sized BTM projects. Additionally, FOM projects take **more than double** the time to complete the interconnection process. Both factors make it difficult to secure funding for FOM projects (for more details, see [Appendix B, Barriers to FOM interconnection](#)).

Several potentially mitigatable factors account for these current differences. First, FOM interconnection costs cannot be definitively determined prior to application from publicly available information. Second,

FOM interconnections are not allowed on existing customer service line drops, adding substantial costs and complexity, including unnecessary construction, scheduling, and potential transfer of ownership related to new service facilities. Third, FOM projects face significant delays during interconnection studies of impact and cost responsibility.

Additional pilot components for consideration

Future considerations involve policy innovations such as the following (for more on these, see [Appendix C, Policy innovations to streamline FOM interconnection](#)):

- Reconsidering confidentiality of interconnection information
- Enhanced ICA data and modeling access
- Combined Interconnection Applications for DER aggregations
- Direct utility upgrade ownership without transfer
- Permission for qualified third-party utility upgrades
- Networked secondary system interconnections

Appendix B: Barriers to FOM interconnection compared to BTM interconnection

Interconnection is recognized by the California Public Utilities Commission (CPUC) as a significant barrier to developing distributed energy resources (DER) and achieving statewide energy and emission goals. Streamlining interconnection practices is a specific goal of Distribution Resource Planning (DRP), as required by Commission Guidance on implementing AB 327. While interconnection of BTM net energy metered (NEM) facilities has realized efficiencies, identically sized and similarly sited FOM projects suffer from Wholesale Distribution Tariff (WDT) and Rule 21 interconnection processes in IOU service territories that:

- Cost significantly more
- Take much longer
- Are far less predictable

Several mitigatable factors account for these current differences:

1. FOM interconnection costs cannot be definitively determined prior to application from publicly available information.
2. FOM interconnections are not allowed on NEM customer service line drops. This adds substantial costs and complexity, including unnecessary construction, extended scheduling, and potential transfer of ownership related to new service facilities.
3. FOM projects face significant delays during interconnection impact and cost responsibility studies. Where upgrades are required, utility distribution upgrade design, engineering costing (post SGIA), and construction timelines are not being set, communicated, and/or adhered to in a sufficiently predictable and consistent manner.

Comparison of BTM and FOM project costs and timeframes

Factor	BTM 1 MW rooftop project	FOM 1 MW rooftop Fast Track project
Typical cost	\$37,500	\$312,450
Typical timeframe	302.5 business days	723 business days

Some consequences are that:

1. Project developers cannot give reliable estimates to their customers.
2. Customers may have to carry their own facilities loan or leasing costs for what could be considered unreasonably or unpredictably long periods, forgoing revenue to cover these loan or lease costs until facilities are operational.
3. Utilities are not being held sufficiently accountable for communicating and adhering to timelines.

The severity of these issues varies depending on utility, project type, and project size. In general, delays, uncertainties, and lack of communication for FOM projects are serious issues that affect the commercial viability of businesses, the availability of jobs, and the very willingness of companies to operate in the distributed energy sector. Types of projects that are more frequently associated with significant delays and uncertainties include:

- Fast Track FOM energy storage projects taking more than the expected 6 months.

- Metering for solar and storage (with examples of this taking 6-12 months).
- Scheduling PG&E pre-construction site walk meetings (7 months).
- Obtaining final engineering drawings and construction drawing (12 months).
- Residential 5 kW solar systems (with examples of taking 6-12 months for a transformer).

FOM vs BTM project timeline and cost comparisons

As the VGES experience demonstrates, the Fast Track Interconnection process for FOM projects needs to be streamlined to provide transparency and consistency. But as noted above, these issues aren't unique to VGES. Currently, 1 in 10 FOM projects fail due to high interconnection costs and uncertainty surrounding project timelines.

There's also uncertainty about costs, with a huge range of interconnections costs a project might face. While the low end of the spectrum for FOM interconnection is \$42,900, the high end of the range is \$594,800. That range of costs, \$551,900, makes it extremely difficult for a developer to plan for the economics of a project, especially when initial estimates put costs on the low side of the range.

FOM project timeline and costs

FOM rooftop 1 MW Fast Track project development (projects where ICA map indicates sufficient capacity)	Timeframe (business days)			Fees			Costs		
	Max	Min	Typical	Max	Min	Typical	Max	Min	Typical
PRELIMINARY WORK AND SITE CONTROL	371	113	215						
Site selection	2	1	1	\$-	\$-	\$-	\$600	\$200	\$300
Preliminary site evaluation and project screening	2	1	2	\$-	\$-	\$-	\$600	\$150	\$300
Preliminary layouts and performance models	7	1	3	\$-	\$-	\$-	\$4,000	\$1,000	\$2,000
Site control (Lease Option Agreement)	180	60	100	\$-	\$-	\$-	\$40,000	\$15,000	\$25,000
Preapplication reports	60	30	35	\$600	\$300	\$600	\$1,500	\$500	\$1,000
Other site research and selection	120	20	75	\$5,000	\$500	\$1,500	\$15,000	\$3,000	\$9,000
INTERCONNECTION REQUEST AND INITIAL REVIEW	50	23	37						
Prepare and submit interconnection application	10	3	5	\$800	\$800	\$800	\$20,000	\$5,000	\$10,000
Utility deems application complete	10	5	7	\$0	\$0	\$0	\$0	\$0	\$0
Initial review results	15	15	15	\$0	\$0	\$0	\$4,000	\$2,000	\$3,000
Developer requests initial review results meeting or proceeds to supplemental review	10	0	5	\$0	\$0	\$0	\$0	\$0	\$0
Initial review results meeting (if clear, go to GIA cost estimate or GIA)	5	0	5	\$0	\$0	\$0	\$1,000	\$500	\$750
INTERCONNECTION SUPPLEMENTAL REVIEW	110	50	70						
Decide to proceed to Supplemental Review	15	0	5	\$2,500	\$2,500	\$2,500	\$600	\$150	\$300
Supplemental review results	60	20	30	\$0	\$0	\$0	\$4,500	\$2,100	\$3,300
Developer requests supplemental review results meeting	15	0	5	\$0	\$0	\$0	\$0	\$0	\$0
Supplemental review results meeting	5	0	5	\$0	\$0	\$0	\$1,000	\$300	\$500
Decide to proceed to GIA draft	30	30	30	\$0	\$0	\$0	\$0	\$0	\$0
POWER SALES CONTRACT	340	100	180						
Review power sales options	100	20	60	\$0	\$0	\$0	\$5,000	\$2,000	\$3,500
Obtain Power Purchase Agreement	240	80	120	\$2,000	\$0	\$1,000	\$20,000	\$5,000	\$12,500
Negotiate GC/EPC and engineering contracts	30	10	20	\$-	\$-	\$-	\$10,000	\$1,000	\$5,000
GENERATOR INTERCONNECTION AGREEMENT (GIA)	60	1	30						
GIA negotiations and signatures (90 Calendar Day max time allowed)	60	1	30	\$0	\$0	\$0	\$5,000	\$2,000	\$3,500
GRID UPGRADES CONSTRUCTION	250	0	190						
Grid upgrade costs				\$0	\$0	\$0	\$300,000	\$0	\$150,000
O&M costs (Cost of Ownership or COD)				\$0	\$0	\$0	\$150,000	\$0	\$75,000
Coordinate upgrade construction with utility, deed transfers				\$0	\$0	\$0	\$10,000	\$2,000	\$6,000
PTO				\$0	\$0	\$0	\$1,000	\$500	\$750
COD				\$0	\$0	\$0	\$1,000	\$500	\$750
Totals (accounting for overlapping times)	1181	287	723	\$10,900	\$4,100	\$6,400	\$594,800	\$42,900	\$312,450
Typical totals			723			\$6,400			\$312,450

BTM project timeline and costs

BTM rooftop 1 MW project development (third-party owned)	Timeframe (business days)			Fees			Costs		
	Max	Min	Typical	Max	Min	Typical	Max	Min	Typical
PRELIMINARY WORK	245	30	45						
Customer acquisition and site selection	75	5	20	\$-	\$-	\$-	\$10,000	\$2,500	\$5,000
Preliminary site evaluation, Pre-application Reports, and project screening	60	5	10	\$2,600	\$600	\$1,600	\$10,000	\$2,500	\$5,000
Preliminary layouts and performance models	30	5	5	\$-	\$-	\$-	\$4,000	\$1,000	\$2,000
Avoided cost and project models	20	5	5	\$-	\$-	\$-	\$3,000	\$1,000	\$1,000
Proposal and LOI	60	10	5	\$-	\$-	\$-	\$3,000	\$1,000	\$1,000
POWER SALES CONTRACT	140	40	50						
PPA/lease negotiation	60	10	20	\$-	\$-	\$-	\$3,000	\$1,000	\$1,000
Site due diligence (structural, roof condition, soils, electrical/services, etc)	50	20	20	\$-	\$-	\$-	\$10,000	\$1,000	\$5,000
Negotiate GC/EPC and engineering contracts	30	10	10	\$-	\$-	\$-	\$10,000	\$1,000	\$5,000
INTERCONNECTION REQUEST AND GENERATOR INTERCONNECTION AGREEMENT	150	50	105						
Prepare and submit interconnection application; receive response from IOU	90	20	60	\$145	\$145	\$145	\$20,000	\$5,000	\$10,000
Negotiate NEMEXP IA (Form 79-978, for 1,000 watts or less)	60	30	45	\$-	\$-	\$-	\$3,000	\$250	\$500
GRID UPGRADES CONSTRUCTION	200	0	180						
Grid upgrade costs				\$0	\$0	\$0	\$0	\$0	\$0
Coordinate upgrade construction with utility				\$0	\$0	\$0	\$5,000	\$500	\$1,000
PTO				\$0	\$0	\$0	\$1,000	\$250	\$500
COD				\$0	\$0	\$0	\$1,000	\$250	\$500
Totals (accounting for overlapping times)	590	75	302.5	\$2,745	\$745	\$1,745	\$83,000	\$17,250	\$37,500
Typical totals			302.5			\$1,745			\$37,500

Appendix C: Policy innovations to streamline FOM interconnection

The VGES 2-BESS case study, and the issues detailed in Appendix B above, highlight the need to improve FOM interconnection. In addition to the proposed Pilot for Streamlining Fast Track FOM Energy Storage Interconnection, the following are the primary policy innovations needed to streamline the FOM interconnection process. CPUC action is needed to implement these policy innovations, and it will be crucial to collaborate with the utilities to address the issues that were uncovered during VGES and to determine potential solutions before jointly submitting the issues to the appropriate policy bodies.

Adopt a standard fee to mitigate prohibitive interconnection costs

As the VGES Project has illustrated, current project economics, as well as uncertainties, make FOM interconnection costs prohibitive. As the **single most important policy innovation to streamline FOM interconnection**, the Clean Coalition is proposing a **Fixed Fee & Utility Pays (FixUP)** policy to extend the streamlined BTM interconnection processes, timing, and price certainty to small FOM projects.

FixUP will allow FOM projects to determine whether they qualify for Fixed Fee interconnection, based on publicly accessible eligibility criteria. Further, all FOM projects that are no greater than 1 MW will avoid the bureaucratically complex and unnecessary process of having to pay for grid upgrades and then legally deed those upgrades to the utility, as well as avoiding the need for an escrow account, which eliminates further complexities and costs. The Clean Coalition estimates that FixUP will yield an average of at least **\$25,000 in bureaucratic savings alone** per FOM project.

For details, see [Appendix E, Fixed Fee & Utility Pays \(FixUP\) for small FOM interconnections](#).

Develop cost-effective Feed-In Tariffs (FITs) to unleash FOM projects

The auction process employed for FOM projects in California is expensive, slow, and risky, delayed by many rounds of proposals, evaluation, negotiation, and approvals. This raises costs for all parties, including ratepayers, and results in far fewer projects being built. Across California Renewable Portfolio Standard (RPS) solicitations, for example, fewer than 1 in 10 project bids have actually been developed — resulting in high administrative costs for the program and exorbitant risks and costs for renewable energy project development. As illustrated in the chart below, **roughly 97% of the bid capacity fails to reach contract, and 30-50% of the contracts fail to achieve online operation**.

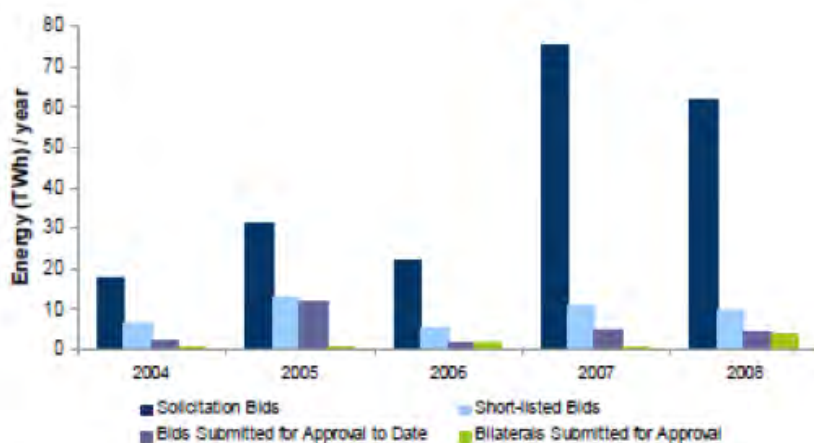

Source: California Public Utilities Commission, 2nd Quarter 2009

In contrast, innovative FITs with Market Responsive Pricing like the ones [the Clean Coalition designs](#), which also feature streamlined interconnection, are highly effective for deploying FOM projects. FITs are faster, cheaper, and more reliable than auctions because they are simpler for developers, property owners, utilities, and regulators. The standardized contracts and prices of FITs can be approved in a single decision — compared to the many rounds of proposals, evaluation, negotiation, and approvals that delay auctions — saving both time and money. The [German FIT program](#), which made Germany a global solar leader, includes Utility Pays interconnection (as in our proposed FixUp policy), with no fees assessed to FOM projects.

Allow FOM resources to participate in more markets and regulatory programs

Also helpful will be to allow FOM resources access to participate in a greater number of markets and regulatory programs; however, this is a longer-term solution. The CPUC has two programs that would be suited for an FOM energy storage project like VGES: the Standard Operating Contract DER Deferral Pilot Program and the Emergency Load Response Program, as well as other traditional demand response programs. Energy storage can participate in CAISO markets as non-generating resources, proxy demand resources, or reliability demand response resources.

Change project confidentiality rules

PG&E currently considers project-specific interconnection information to be confidential, but developers generally do not request confidential treatment of this information. As seen in PG&E's service territory, providing details on interconnection study results, with identifying information redacted upon request, can reduce timelines and costs for all parties and potentially foster collaboration. The Clean Coalition proposes to work with the CEC, PG&E, and developers to determine the universe of interconnection information that should by default be deemed not confidential unless the applicant opts out. Information would include constraints discovered through the study process, as well as the types of upgrades and costs associated with them.

Provide enhanced ICA data and modeling access

The purpose of providing enhanced ICA data and modeling access is not only to show how much capacity is available without grid upgrades, but also to allow applicants to determine what upgrades are cost-effective prior to submitting an application. Enhanced ICA data on each component of capacity limits will allow applicants to determine how to limit their project's operational profile, or alternatively how much additional hosting capacity may result from upgrading one or more limiting factors, should it be cost-effective to do so. On-demand, online modeling practices could allow applicants to input project design through a web interface to analyze what violations occur, along with information on why and by what degree, to allow applicants to optimize system size and design relative to impact mitigation costs.

Allow combined Interconnection Applications for DER aggregations

This proposal would allow aggregations of DER to apply for interconnection together and for PG&E to determine how the resources may respond both individually and in aggregate. The application process would take into consideration the ability of software to impose operational constraints that would prevent otherwise necessary grid upgrades. Operational standards and liability stipulations would be included in interconnection agreements for eligible resources. This proposal supports other efforts currently under way. For example, the Integrated Distributed Energy Resources (IDER) Pilot DER solicitation framework will result in developers proposing portfolios of DER to meet identified grid needs. PG&E will need more visibility into how the resources will behave when called upon in aggregate. The Group Study

interconnection process addresses how to share fees in electrically related areas but does not consider coordinated operation of DER.

Allow direct utility upgrade ownership without transfer

Currently, upgrades are paid for by developers and deed-transferred to the utility, which results in a complex process and unneeded tax liabilities. Instead, where upgrades are required, PG&E could own and install the assets and assess an interconnection upgrade fee based on work performed, avoiding an ownership transfer process and the associated Income Tax Component of Contributions (ITCC) liabilities.

Give permission for qualified third-party utility upgrades

Rule 21 currently allows interconnection applicants to hire qualified third-party providers to perform required upgrades, subject to utility discretion. Under this proposal, PG&E would identify contractors that are currently qualified to perform work for the utility, creating a pathway to allow developers to contract with these third parties directly. This effort would address scheduling delays in service planning while likely reducing costs and increasing transparency. PG&E would maintain authority over upgrade requirements, equipment specifications, final inspection, and approval of all work performed (as an alternative to direct utility upgrade ownership).

Allow networked secondary system interconnections

Special considerations must be given to generating facilities proposed to be installed on networked secondary systems because of the design and operational aspects of network protectors. This proposal will explore opportunities to include networked secondary interconnections under specific defined conditions, including the use of existing service lines.

Appendix D: Fixed Fee & Utility Pays (FixUP) proposal for small FOM interconnections

Goal

The goal of the Fixed Fee & Utility Pays (FixUP) policy innovations is to extend the streamlined BTM interconnection processes, timing, and price certainty to small FOM projects.

Overview

FOM interconnection is hobbled by numerous barriers, but two of the biggest barriers can be eliminated with the straightforward FixUP policy innovations. FixUP will allow FOM projects to determine whether they qualify for Fixed Fee interconnection, based on publicly accessible eligibility criteria. Further, all FOM projects that are no greater than 1 MW will avoid the bureaucratically complex and unnecessary process of having to pay for grid upgrades and then legally deed those upgrades to the utility, as well as avoiding the need for an escrow account, which eliminates an additional bundle of complexities and costs. The Clean Coalition estimates that FixUP will yield an average of at least **\$25,000 in bureaucratic savings alone** per FOM project.

Importantly, FixUP merely treats small FOM projects in a similar manner to BTM projects of up to 1 MW. From a physical standpoint, FixUP-eligible FOM and BTM projects have identical impacts on the grid; their interconnections should benefit from equally straightforward processes accordingly. Sadly, that is far from the case today, with FOM interconnection processes being far more costly, lengthy, and uncertain. Even more sadly, existing FOM interconnection processes cause the death of the vast majority of projects that have to face them.

FixUP resolves these issues by providing deterministic and reasonable costs upfront and eliminating a heap of costly, time-consuming, and unnecessary bureaucratic complexity.

Fixed Fee eligibility

FOM projects will be eligible for Fixed Fee pricing if they meet the following three criteria:

- Sized under 1 MWac.
- Sited on the property of a utility customer.
- In aggregate, sized less than the associated service rating of the site where the FOM project will be located. For example, projects sited at an apartment complex with an aggregate service rating of 800 kW will be Fixed Fee eligible for FOM projects that are less than 800 kW in aggregate capacity.

Fixed Fee amount

The Fixed Fee amount will be set at a revenue-neutral level, based on average actual costs incurred by the utility. Initially, \$10,000¹ is estimated to be appropriate for the Fixed Fee amount and covers the Pre-Application Reports (PAR), Fast Track (FT) Application, review, and approval, and Fast Track Supplemental Review (SR). See the tabular view below. Of course, the Fixed Fee does not include facility costs on the

¹ PAR, FT/SR application, review, and study fees are already standardized based on average costs (\$600 + \$800 + \$2,500 = \$3,900). With the average cost of results review meetings ~\$750, this total fee of \$10,000 allows \$5,350 for the average cost of pre-construction meetings, final construction drawings and engineering costing, site visits for inspection, and actual interconnection. See table for more details.

FOM project side of the point of common coupling, as those are costs of the project and are always owned as part of the project.

Breakdown of initial FOM interconnection Fixed Fee amount

Description	Fees
Pre-application report	\$600
Application submittal / Scoping meeting (Fast Track and standardized interconnection fee approval)	\$800
Technical study / Supplemental Review	\$2,500
Results review meetings	\$750
Pre-construction meetings, final construction drawings, engineering costing, site visits for inspection, and actual interconnection	\$5,350
Total:	\$10,000

Utility Pays process

For FOM projects that are no larger than 1 MW and that do not meet all of the other Fixed Fee eligibility criteria, the utility will still directly pay for any interconnection costs to streamline the interconnection process for these small FOM projects and then recover those costs based on standardized unit costs, which each utility already publishes annually. In addition to the Fixed Fee, the projects will pay fixed fees for required grid upgrades based on the published equipment unit costs. The Utility Pays approach will provide significant streamlining and price certainty by eliminating the complex and unnecessary processes associated with paying the utility to perform grid upgrades and then having to deed those same grid upgrades to the utility. This also avoids the need for an escrow account, which eliminates an additional bundle of complexities and costs. Importantly, Utility Pays streamlines processes for the utilities too, thereby saving ratepayers from paying for unnecessary and wasteful bureaucracy on the utility side.

Based on PG&E’s current WDT Unit Cost Guide,² the following standard costs are examples of fees that could be added to the Fixed Fee amount for FOM projects up to 1 MW that do not meet the remaining Fixed Fee eligibility criteria:

Grounding/Stabilizing Transformer- Padmounted	\$52,000
Conductor (Per feet) - Overhead-Urban	\$220/ft (Bay cost)
Reconductor (Per feet) - Overhead-Rural	\$160/ft (Non-Bay cost)
Reconductor (Per feet) - UG	\$260/ft (Non-Bay); \$315/ft (Bay cost)
Overhead Fuses	\$10,000

One section of PG&E’s WDT Unit Cost Guide

With an upfront fee-based structure for all FOM projects of up to 1 MW, FixUP streamlines the interconnection process for small FOM projects, including by eliminating the complex and unnecessary deeding process — saving time, energy, and money for all parties involved, including ratepayers.

² See PG&E’s 2021 WDT Unit Cost Guide here: https://www.pge.com/pge_global/common/pdfs/for-our-business-partners/interconnection-renewables/Unit-Cost-Guide.pdf

Appendix E: PG&E's Wholesale Distribution Generation Interconnection Process for FOM projects

The VGES Project went through the Fast Track Interconnection process available for qualifying FOM projects under PG&E's Wholesale Distribution Generation Interconnection Process.



Wholesale Distribution Generation Interconnection Process ³



- PG&E's distribution voltage level: facilities operating below 60 kV
 - Governed by PG&E's Wholesale Distribution Tariff (WDT)
 - All applications must be submitted to PG&E
 - This presentation supplements WDT Attachment I



Application Processing Timeline (Independent Study Process and Fast Track Process) ⁴



Milestone	Duration	Responsible Party
Submit application	Clock start	Customer
Deem application complete or provide notice of outstanding items	10 BD	PG&E
Provide outstanding items or request extension	10 BD	Customer
Provide outstanding items if extension requested	20 BD*	Customer
Deem application complete		PG&E

* PG&E Extension Business Rule BD – Business Day



Application Processing Timeline (Cluster Study Process)

5



Process Milestone	Duration	Responsible Party
Submit application	Clock start	Customer
Deem application complete or provide notice of outstanding items	10 BD	PG&E
Provide outstanding items	10 BD from deemed incomplete notification or 20 BD from close of cluster application window	Customer
Notify customer of whether application is complete	5 BD after additional information is provided	PG&E
Deem application complete		PG&E

BD – Business Day



Complete Distribution Interconnection Application

6

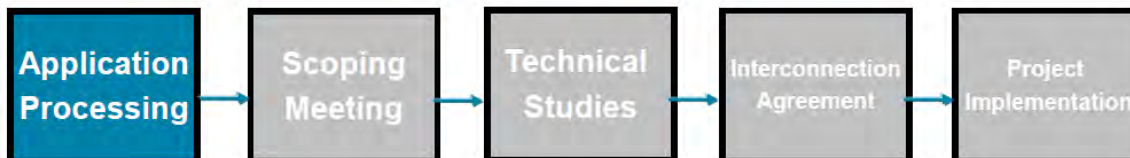

Include:

- Completed application (with Appendix A)
- Site plan diagram
- Single-Line Diagram
- Application fee*
- Site control document

*Application fee paid after PG&E issues invoice letter



Distribution Interconnection Application

7



- Submit complete interconnection application* online at <http://pge.com/wholesale/apply>
- Direct inquiries to the Application Desk at WholesaleGen@pge.com

*GIS will send your invoice letter with instructions on wire payment after we receive your interconnection request



Scoping Meeting Purpose

8



Scoping meeting:

- Ensures common understanding of project
- Ensures customer understanding of generator interconnection process
- Secures agreement on point of interconnection and generator size
 - PG&E provides technical system details, limitations and queued-ahead projects
- Advises which process (Independent, Fast Track or Cluster study) customer qualifies for and studies to be conducted
- Determines next steps

Five business days after scoping meeting, customer must confirm point of interconnection and generator size.



Scope of Studies



Technical studies:

- Show impact of generation on PG&E’s electric system
- Show capital improvements to PG&E’s electric system required to ensure safety, reliability and integrity of the grid:
 - Generator-specific facilities required for interconnection
 - Distribution upgrades to be triggered by generator or cluster
- Provide schedule and cost estimate for scope of capital improvements



Interconnection Study Process

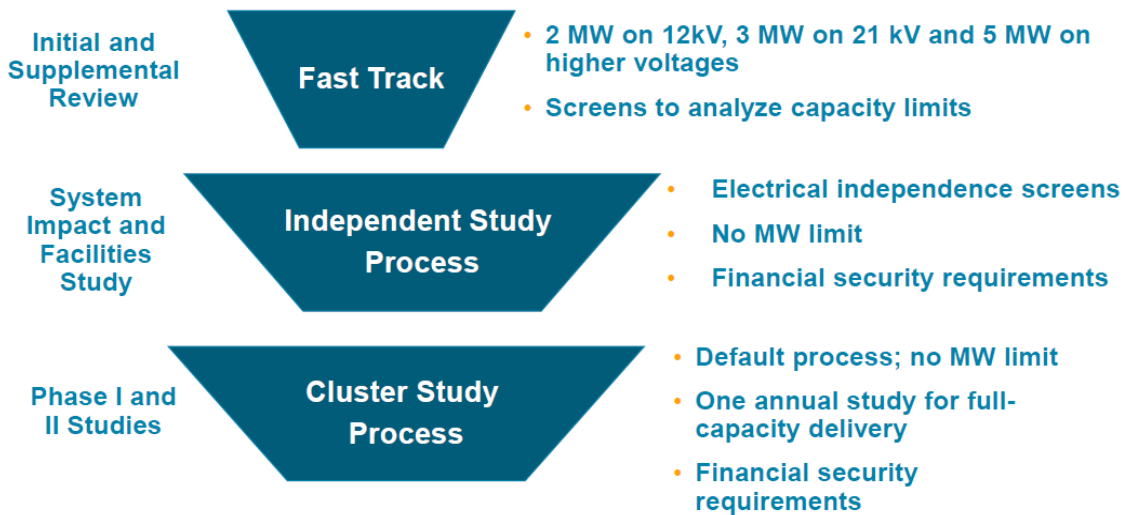

Customers requesting an Independent Study Process or a Cluster Study Process may apply for Full-Capacity Delivery. (Full-Capacity Delivery is the generating facility's ability to deliver its full output to the grid without constraints.)



Study Results

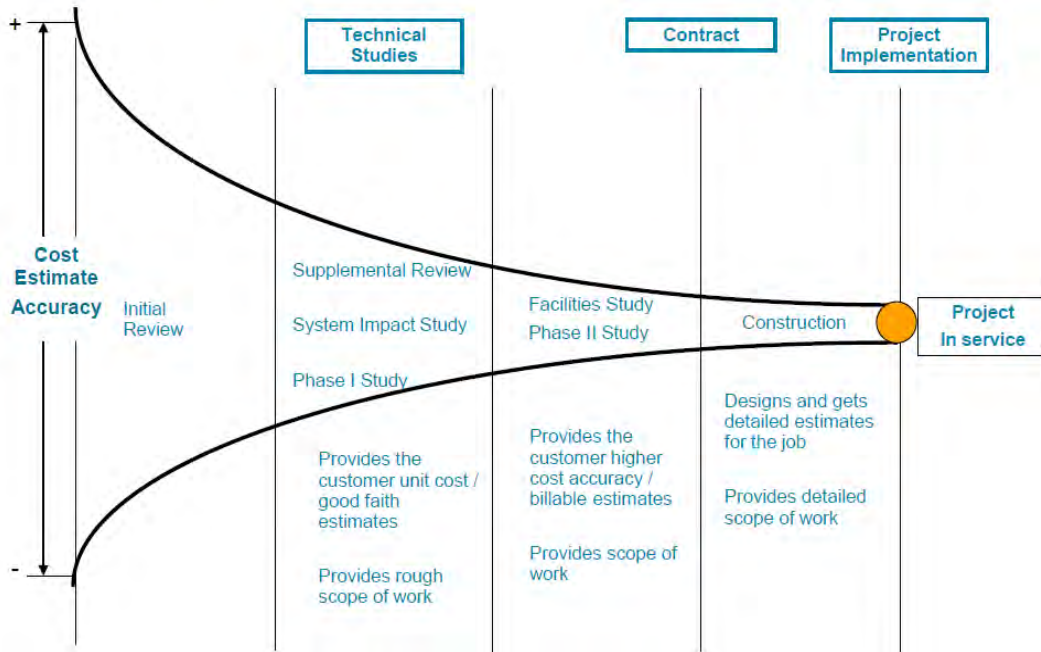

Fast Track Process

Tariff section	2
Applicability	Must pass screens
MW limit	2MW on 12kV 3MW on 21kV 5MW on higher voltages
Application fee	\$500 (includes initial review)

Study	Timing	Fee
Initial review	15 BD	Included in application fee
Supplemental review	10 BD	\$1,500 deposit

BD – Business Day



Independent Study Process

13

Tariff section	3
Applicability	Electrical Independence Test
MW limit	No limit
Application fee	\$50K plus \$1K/MW (max \$250K)

Study	Timing	Fee
System impact study	60 BD	Included in app fee
Facilities study	60 BD	Included in app fee

BD – Business Day



Cluster Study Process

14

Tariff section	4
Applicability	Default
Cluster application window	See section 4.1 of Generation Interconnection Procedures
Application fee	\$50K plus \$1K/MW (max \$250K)

Study	Timing	Fee
Phase I	134 CD	Included in app fee
Phase II	196 CD	Included in app fee

CD – Calendar Day



Financial Security Postings

Posting Number	Posting Type	Posting Amount	Timing	Phase
Initial	Interconnection facilities and distribution upgrades	Lesser of 20% or \$20K/MW	30 CD	After System Impact Study (ISP)
	Network upgrades	15% or \$20K/MW or \$7.5M (>20MW)	90 CD	After Phase I (Cluster)
Second	Interconnection facilities and distribution upgrades	30%	120 CD	After Facilities Study (ISP)
	Network upgrades	30% or \$1M (<20MW) or \$15M (>20MW)	180 CD	After Phase II (Cluster)
Third	Interconnection facilities and distribution upgrades	100%	On or before start of construction	After Interconnection Agreement (acquisition of permits)
	Network upgrades	100%		

CD – Calendar Day



Financial Security Posting Instructions

Links to the following forms can be found on the Additional Resources page of <http://pge.com/wholesale> under: “Wholesale Distribution Financial Postings Resources” including:

- Letters of Credit
- Escrow Agreements
- Surety Bonds
- Guaranty Agreements

For Certificate of Deposit or Payment Bond Certificates, please contact PG&E to determine acceptable forms



Interconnection Agreement

17



Small Generator Interconnection Agreement (SGIA) – 20 MW or less
 Large Generator Interconnection Agreement (LGIA) – greater than 20 MW

Process Milestone	Duration	Responsible Party
Provide final study results	Clock start	PG&E
Tender Interconnection Agreement (IA)	30 CD/15 BD (Fast Track)	PG&E
Respond to draft	30 CD	Both
IA negotiated and agreed on	90 CD from clock start	Both
PG&E issues executable IA	15 BD	PG&E
Execute IA	ASAP	Both
Post final posting (except Fast Track)	On or before start of construction	Customer

BD – Business Day CD – Calendar Day



Project Implementation

18



- **Post-Interconnection Agreement, PG&E and customer engineer, design, procure and construct (EPC) electrical interconnection**
 - PG&E engineers capital improvements per Interconnection Agreement
 - Customer engineers electrical system on customer side of meter and any upgrades to be customer-built and deeded
- **Post-EPC, PG&E and customer coordinate pre-parallel inspection and commissioning to achieve commercial operation**



Distribution Deliverability Assessment

19

- Customers who apply for interconnection under the Independent Study Process or Cluster Study Process can request a Deliverability Assessment
 - Customers can request that CAISO perform a Deliverability Assessment by selecting “Full Capacity” on the Interconnection Request form submitted to PG&E
- All generating facilities interconnected under the Fast Track Process will have “Energy-Only” deliverability status
 - Fast Track or other Energy-Only customers may apply for Full Capacity using the Additional Deliverability Assessment Options under WDT GIP Section 4.22



Interconnection Resources

20

- PG&E Wholesale Generation Interconnections website:
<http://pge.com/wholesale>
 - PG&E’s Public Distribution (WDT) Queue
 - Getting Started Guides
 - Application Checklists
 - Online Application at <http://pge.com/wholesale/apply>
- Questions? Contact wholesalegen@pge.com

Distribution Schedule Summary

Fast Track Process

		2011 (weeks)																																																																								
		6	7	8	9	10	11	12	13	14	15	16	17	18	19	20	21	22	23	24	25	26	27	28	29	30	31	32	33	34	35	36	37	38	39	40	41	42	43	44	45																																	
IR Validation	Initial Review	Options Mtg	Supp Review Agmt	Supp Review	IA	EPC																																																																				
			IA	EPC																																																																						

Independent Study Process

		2011 (bi-weeks)																		2012 (bi-weeks)																								
		3	4	5	6	7	8	9	10	11	12	13	14	15	16	17	18	19	20	21	22	23	24	25	26	1	2	3	4	5	6	7	8	9	10	11	12	13	14	15	16	17	18	1
IR Validation	Scoping Mtg	SIS Agmt (15 BD)	System Impact Study 60 BD						Security Posting	Facilities Study 60 BD						IA	EPC																											

Cluster Study Process

		2011 (Monthly)												2012 (Monthly)												2013 (Monthly)											
		Jan	Feb	Mar	Apr	May	Jun	Jul	Aug	Sep	Oct	Nov	Dec	Jan	Feb	Mar	Apr	May	Jun	Jul	Aug	Sep	Oct	Nov	Dec	Jan	Feb	Mar	Apr	May	Jun	Jul	Aug	Sep	Oct	Nov	Dec
Queue Window	IR Validation	Scoping Mtg	Phase I Study						Results Mtg	Security	Phase II Study						IA	EPC																			

Definitions

Distribution Upgrades – Additions, modifications and upgrades to the distribution provider's distribution system at or beyond the point of interconnection that facilitate interconnection of the GF and render the service necessary to effect the Interconnection Customer's wholesale sale of electricity in interstate commerce. Distribution upgrades do not include interconnection facilities.

Distribution System – Those non-ISO transmission and distribution facilities owned, controlled and operated by the Distribution Provider that are used to provide distribution service under the Tariff, which facilities and equipment are used to transmit electricity to ultimate usage points such as homes and industries directly from nearby generators or from interchanges with higher voltage transmission networks which transport bulk power over longer distances. The voltage levels at which Distribution Systems operate differ among areas.

Interconnection Facilities – The distribution provider's and interconnection customer's interconnection facilities. Interconnection facilities include all facilities and equipment between the generation facility (GF) and the point of interconnection, including any modifications, additions or upgrades necessary to physically and electrically interconnect the GF to the distribution provider's distribution system. Interconnection facilities are sole-use facilities and do not include distribution upgrades or network upgrades.

Network Upgrades – Additions, modifications, and upgrades to the distribution provider's transmission system required at or beyond the point at which the distribution system connects to the distribution provider's transmission system to accommodate the interconnection of the GF to the distribution provider's transmission system. Network upgrades do not include distribution upgrades.

Point of Interconnection – The point where the interconnection facilities connect with the distribution provider's distribution system.

Upgrades – The required additions and modifications to the distribution provider's transmission system and distribution system at or beyond the point of interconnection. Upgrades may be network upgrades or distribution upgrades. Upgrades do not include interconnection facilities.

Appendix F: VGES interconnection review experience with PG&E

In contrast to the expected process outlined in the previous appendix, the following Interconnection Application (IA) timeline notes for VGES illustrate the issues and delays experienced in the interconnection review for this project.

- 12/3/2017: WDAT Interconnection Applications are submitted for VGES 1 and VGES 2. VGES 1 (different site location) was eventually withdrawn and VGES 2 was moved (see 5/2/2018).
- 12/8/2017: PG&E takes 5 days to confirm receipt of VGES 1 application; no confirmation is received for VGES 2 application. (5 days)
- 12/8/2017: PG&E advises in confirmation that an invoice for each system will be following shortly. (5 days)
- 12/11/2017: PG&E takes 8 days to confirm receipt of VGES 2 application and re-confirms VGES 1 application. (8 days)
- 12/11/2017: Invoices for both applications are received; however, the expected \$800 fee is increased to \$1,800 with no explanation. The CEO of the project EPC contacts the PG&E Project Manager (PM) assigned to the project to discuss the reason behind the increase. (8 days)
- 1/17/2018: Between 12/11/2017 and 1/17/2018, EPC CEO attempts numerous times to contact the PG&E PM to discuss the \$1,800 fee for each application; EPC CEO finally reaches the PM, who explains that the \$1,800 is PG&E's engineering study fee and advises that in order for PG&E to move forward with the next step of reviewing the application for completeness, the fee must be paid in full; EPC CEO pays both invoices. (38 days)
- 1/24/2018: "APPLICATION DEEMED COMPLETE" received for both applications; subcontractor and EPC feel the interconnection process to get to the executed SGIA is still on track for March 2018.
- 1/29/2018: EPC CEO reaches out to the Interconnection Manager at PG&E to learn the status of the applications. The PG&E Interconnection Manager indicates to EPC CEO that everything is on track; however, we may need to go to Supplemental Review, but results from PG&E will not be available until around 2/14/2018. (48 days)
- 2/20/2018: PG&E advises that Supplemental Review is recommended due to FOM system configurations. EPC instructs PG&E to move forward to Supplemental Review. (3 months and 2 weeks)
- 3/22/2018: PG&E notifies EPC CEO that the previous PM assigned to project has been re-assigned and a new PM has been assigned.
- 4/11/2018: **Delay notification received from PG&E.** The notice advises that the Supplemental Review scheduled to be completed on 4/12/2018 will now be completed on 4/26/2018. (4 months and 4 days)
- 4/12/2018: EPC CEO speaks with the PM, who informs EPC CEO that the Supplemental Review delay is due to the California wildfires.
- 4/25/2018: Supplemental Review results are received: PASS with mitigation. Supplemental Review results include estimated utility costs (\$188,313) and options to proceed — one option is to request a Supplement Review meeting. The results note PG&E's engineering recloser requirement and the separation of VGES 1 from VGES 2 battery grid connection. (4 months and 15 days)
- 4/27/2018: The Clean Coalition, the project subcontractor, and the EPC meet to discuss the Supplemental Review results and next steps. A decision is made to move forward with a

Supplemental Review Meeting. The EPC CEO notifies the PG&E PM and receives dates and times options; the Supplemental Review Meeting is scheduled for 5/2/2018.

- 5/2/2018: The Clean Coalition, subcontractor, EPC CEO, and PG&E PM and engineer meet to discuss the Supplemental Review results and options for moving forward:
 - Accept the Supplemental Review results and move to a Small Generator Interconnection Agreement (SGIA).
 - Withdraw the project from further consideration in the Fast Track Interconnection Process.
 - Eliminate VGES 1 and continue forward with VGES 2 in its current configuration.
 - Keep generation size of VGES 2 at 500 kW but install a generation-limiting scheme to cap inverter output to mitigate upgrades.
 - Incorporate VGES 1 into VGES 2, thereby increasing VGES 2 to 750 kW, but install a generation-limiting scheme to cap generation output.
- 5/21/2018: PG&E is notified of decision on moving forward: VGES 1 is withdrawn, VGES 2 will proceed with no change to the inverter and will remain at 500 kW; proposal changes VGES 2 to be connected via the battery bank; revised SLD is submitted (with no change to VGES 2 inverter or switchgear). A follow-up meeting is requested to discuss eliminating the SCADA recloser and using subcontractor's Energy Management System (EMS) to limit the combined export of the solar and the energy storage to 1 MW (specifications submitted to PG&E). (5 months and 13 days)
- 5/29/2018: PG&E informs EPC CEO that the proposed VGES 2 changes would trigger a re-study and that an EMS managing maximum output of solar and storage would not be considered; proposed changes are not allowed due to tariff restrictions. Options are received on how to move forward: a) retract request for VGES 2 and EMS and move forward to SGIA (IA), b) withdraw VGES 2 from the Distribution Interconnection Queue and submit a new Interconnection Request (not an option, as the project loses its place in the queue), or c) withdraw VGES 2 entirely. A decision is made to go with option a; still waiting on request to remove recloser and to connect VGES 1 and VGES 2 via the battery pack.
- 5/31/2018: PG&E accepts the proposed changes of connecting VGES 2 via the battery pack; recloser decision still pending.
- 6/21/2018: PG&E completes its secondary Supplemental Review and results are received. The SCADA recloser is not removed from the system configuration. EPC CEO follows up with the PG&E PM asking why the recloser was not removed; PG&E indicates that VGES 2 is still greater than 1 MW (48 kW over). A request is submitted for waiver on the 48 kW, but the PG&E engineer will not consider this due to safety protocols for the grid. (6 months and 13 days)
- 6/21/2018 – 7/3/2018: IA negotiations continue.
- 7/3/2018: Draft IA received with a Permission to Operate/Commercial Operation Date (PTO/COD) date of 10/15/2020; the Clean Coalition, subcontractor, and EPC CEO discuss system changes and utility construction schedule, which are unacceptable. The decision is made to continue with IA negotiations; PG&E is notified of decision along with submission of requested proposed PTO/COD 9/15/2019. (7 months and 20 days)
- 7/3/2018 – 9/5/2018: Negotiations continue on PTO/COD date.
- 9/10/2018: SGIA is finalized with an agreed-upon PTO/COD of 11/15/2019; revised draft SGIA to be received 9/10/2018. (9 months and 5 days)
- 9/21/2018: Revised IA is received, but the PG&E PM advises not to sign it as he still needs to have the agreement reviewed and approved by management before the IA can be officially sent out via PG&E's DocuSign email. The PM only needs email confirmation that subcontractor accepts the

IA; subcontractor CEO signs the IA as confirmation of acceptance, and EPC CEO forwards the signed IA to the PG&E PM; however, the PG&E PM requests email confirmation of acceptance. (9 months and 12 days)

- 9/24/2018: The EPC CEO replies to the PG&E PM upon his return to office with an email confirmation acceptance of the IA.
- 9/28/2018: EPC CEO follows up with the PG&E PM on the status of the DocuSign IA, which must go to subcontractor CEO; the PG&E PM advises that it is still being routed through PG&E's system.
- 10/3/2018: EPC CEO follows up again with the PG&E PM on status of the DocuSign IA.
- 10/5/2018: EPC CEO advises during CPR Meeting #1 that the DocuSign IA has been received and executed today; however, the subcontractor's VP of Business Development informs the team that the IA has not been received yet from PG&E. (10 months)
- 10/5/2018: The Project Manager /Principal Investigator at the Clean Coalition invites the Director of the Interconnections Division at PG&E and a Senior Advisor at CAISO to join the core VGES Technical Advisory Committee (TAC). A verbal commitment is received, but the PG&E Interconnections Division Director wants to enlist members from his team and needs time to look at resources; the PG&E Interconnections Division Director has inherited the Design Innovations group and another group consisting of engineers and wants to ensure he selects the right personnel.
- 10/11/2018: Subcontractor receives the IA, which must be reviewed by executive management team and legal before subcontractor CEO can execute (subcontractor CEO is on vacation, returning week of 10/24/2018); the subcontractor's VP of Business Development also forwards a copy of the IA to the CAISO Senior Advisor per his request.
- 10/25/2018: Subcontractor CEO executes the IA via PG&E DocuSign.
- 10/26/2018: The IA is fully executed; subcontractor receives escrow account instructions and begins the process of setting up the account.
- 10/31/2018 – 11/8/2018: The Clean Coalition Project Manager and Contract Management Lead, and the subcontractor's VP of Business Development, engage in continued communications about the escrow account; subcontractor's bank (East West Bank) works with PG&E Credit Risk on account setup.
- 11/15/2018: Escrow account is set up. PG&E Credit Risk continues their due diligence; subcontractor executes the Escrow Agreement and confirms the \$173,763 financial security deposit is secured, thus the wire transfer is ready to go once the escrow account is set up. (11 months and 10 days)
- 11/26/2018: The Escrow Agreement is executed (10 days for PG&E to execute), but account setup is still pending and may take another 10 days, because East West Bank is not in PG&E's preferred vendor database.
- 11/26/2018 – 12/14/2018: East West Bank continues working with PG&E Credit Risk on escrow account setup.
- 12/14/2018: The escrow account is set up and the \$173,763 financial security posting transaction is completed. (12 months and 7 days; 10 days for escrow account to be set up post execution of Escrow Agreement)

Appendix G: VGES interconnection estimated costs

The table below represents the initial estimated costs for the VGES interconnection received from PG&E on 4/25/2018. PG&E also advised that VGES had passed the Supplemental Review but with mitigation. Thus, a Supplemental Review meeting was requested by the subcontractor and the project EPC on 4/27/2018 to review the results. Subsequent to this meeting, the final interconnection costs estimates were received on 5/31/2018, as described in the Table "[VGES 2017 – 2019: Key milestones, impacts, and costs.](#)"

Estimated costs for VGES interconnection

Distribution upgrades	IC cost
San Fran X (Mission) Substation	
No work required	n/a
Mission (X) 1124 Feeder	
PG&E to remove (E) 300 kVA pad-mounted transformer and replace with (N) 750 kVA pad-mounted transformer	\$55,263
Subtotal	\$55,263

Interconnection facilities	IC cost
Generating facility	
Pre-parallel inspection, protection review, and testing witnessing	\$1,000
PG&E to install (N) underground secondary service for battery	\$25,000
PG&E secondary service metering	\$5,000
Customer to install PG&E-approved visible, lockable, gang-operate AC disconnect switch	n/a
Subtotal	\$31,000

Total project costs	IC cost
Total project cost (excludes COO)	\$86,263

Appendix H: VGES integration capacity analysis (ICA) data

San Francisco, the “end of the line”: San Francisco is served by a vulnerable transmission and sub-transmission infrastructure. Interruption of either the transmission to, or the sub-transmission and feeders within, San Francisco may result in outages.

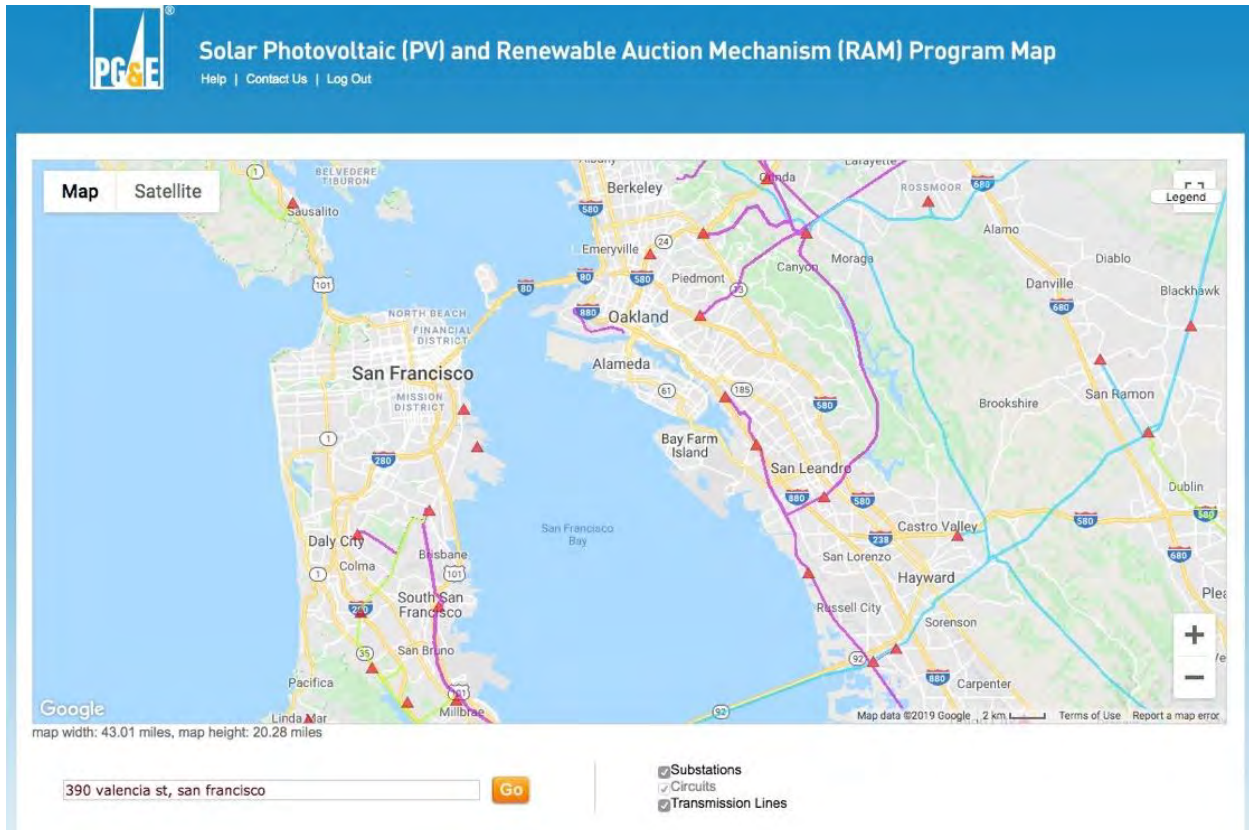

San Fran X (Mission) Substation "XSF" (ID# 2201)

The San Fran X (Mission) 2201 is an urban station serving the local area with > 60 circuits, 1101 - 1162+, on the Mission (X) 1124 Feeder.

A screenshot of a software interface. The main window displays a map with red power lines and a yellow label "MISSION XSF X". A data window is open, titled "MISSION (X) 1124 (022011124)". The window has tabs for "Info" and "Feeder Load Profile". Under the "Info" tab, there is a "Download data" section with the following information:

Feeder Name:	MISSION (X) 1124
FeederID:	022011124
CSV LineSection:	312184
ICA Analysis Date:	Dec 2018
Load Hosting Capacity (kW):	0
Generation Hosting Capacity (kW):	0
Generic PV Hosting Capacity (kW):	0

Circuit 1124 Serving Valencia Gardens Apartments

VGA is on the 1124 circuit.

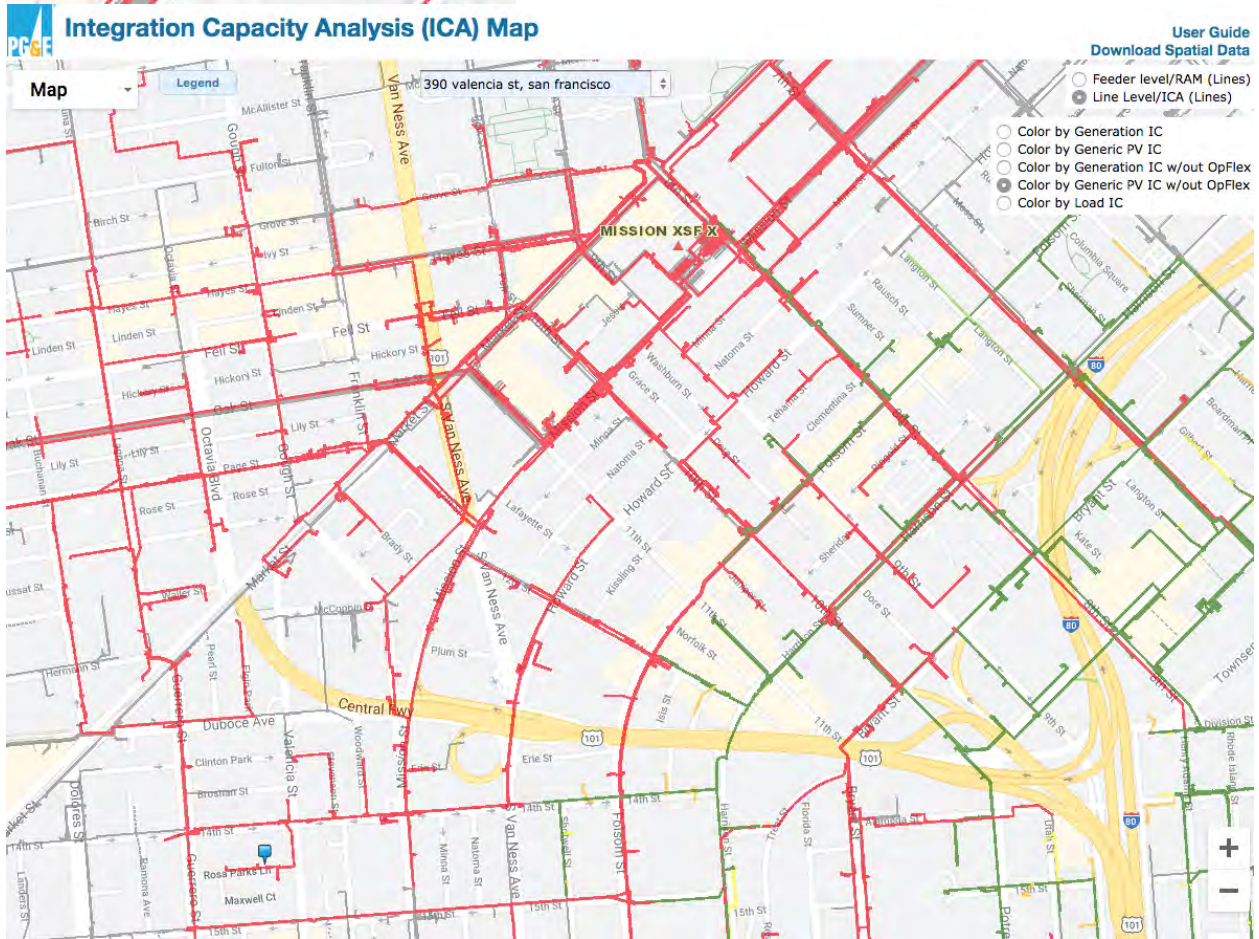



Asset information for Mission (X) 1124

MISSION (X) 1124

1 of 1

Asset Info

Feeder Name	MISSION (X) 1124
Feeder Number	022011124
Nominal Circuit Voltage (kv)	12kv
Circuit Capacity (MW)	9.96
Circuit Projected Peak Load (MW)	5.47
Substation Bank	0
Substation Bank Capacity (MW)	0
Substation Bank Peak Load (MW)	0
Existing Distributed Generation (MW)	0.81
Queued Distributed Generation (MW)	0.05
Total Distributed Generation (MW)	0.86
Total Customers	3410
Residential Customers	2906
Commercial Customers	371
Industrial Customers	118
Agricultural Customers	1
Other Customers	14

ICA map: VGES “section” and “node”

Data containing ICA power flow analysis results for a typical 24 hours for each month can be downloaded from the ICA map. In this instance, voltage and thermal limits were exceeded at all hours. Typical upgrade costs are published annually in the Unit Cost Guide from each IOU; however, a fee-based Pre-Application Report or Interconnection Application and Initial Review are typically required to determine the types of upgrades required.

1	LineSection ID	Load Or Gen	Month	Hour	IC_Thermal _kW	IC_Voltage _kW	IC_Protection _kW	IC_Safety _kW
2	307203	G	1	0	0	0	9947	REDACTED
3	307203	G	1	1	0	0	9947	REDACTED
4	307203	G	1	2	0	0	9947	REDACTED
5	307203	G	1	3	0	0	9947	REDACTED
6	307203	G	1	4	0	0	9947	REDACTED
7	307203	G	1	5	0	0	9947	REDACTED
8	307203	G	1	6	0	0	9947	REDACTED
9	307203	G	1	7	0	0	9947	REDACTED
10	307203	G	1	8	0	0	9947	REDACTED
11	307203	G	1	9	0	0	9947	REDACTED
12	307203	G	1	10	0	0	9947	REDACTED
13	307203	G	1	11	0	0	9947	REDACTED
14	307203	G	1	12	0	0	9947	REDACTED
15	307203	G	1	13	0	0	9947	REDACTED
16	307203	G	1	14	0	0	9947	REDACTED
17	307203	G	1	15	0	0	9947	REDACTED
18	307203	G	1	16	0	0	9947	REDACTED
19	307203	G	1	17	0	0	9947	REDACTED
20	307203	G	1	18	0	0	9947	REDACTED
21	307203	G	1	19	0	0	9947	REDACTED
22	307203	G	1	20	0	0	9947	REDACTED
23	307203	G	1	21	0	0	9947	REDACTED
24	307203	G	1	22	0	0	9947	REDACTED
25	307203	G	1	23	0	0	9947	REDACTED
26	307203	G	2	0	0	0	9947	REDACTED

Appendix I: VGES interconnection SLD from PG&E, showing PCC and POI

This single-line diagram (SLD) was received from PG&E after the technical analysis review for the VGES 2-BESS project, showing the point of common coupling (PCC) and point of interconnection (POI). The SLD shows the major new components for both the applicant and PG&E.

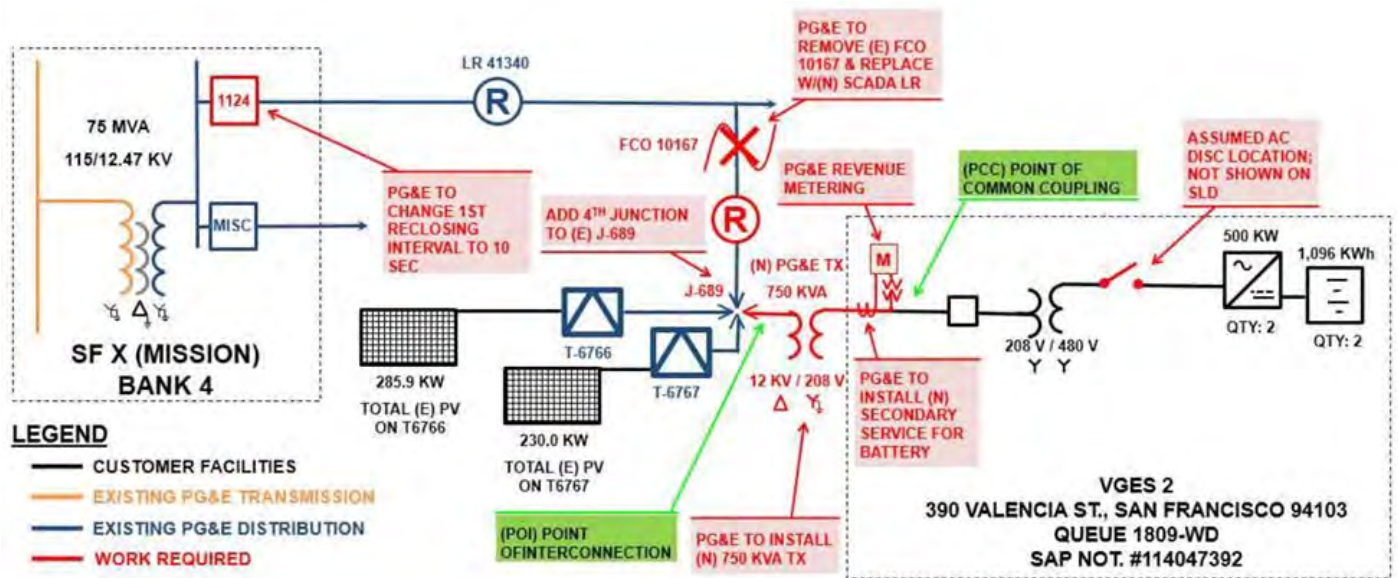

Appendix J: VGES economics forecast

		2020	2021	2022	2023	2024	2025	2026	2027	2028	2029	Assumptions
Operational Cash Flows		Cost Basis										
Electricity Revenues												
Wholesale Sale Price (\$/MWh)	Selected evening/peak hours	\$ 63.39	\$ 64.66	\$ 65.30	\$ 65.96	\$ 66.61	\$ 67.28	\$ 67.95	\$ 68.63	\$ 69.32	\$ 70.01	Bayshore node. NP15 forward curve
Electricity Sold (MWh)	92%	331.23	323.28	315.52	307.95	300.56	293.35	286.31	279.44	272.73	266.18	RT efficiency
Wholesale Sale Revenue (\$)		\$ 20,996.18	\$ 20,902.12	\$ 20,604.47	\$ 20,311.07	\$ 20,021.84	\$ 19,736.73	\$ 19,455.68	\$ 19,178.63	\$ 18,905.52	\$ 18,636.31	
Ancillary Services Revenue												
Regulation Revenue (\$)	Selected by arbitrage schedule	\$ 12,576.29	\$ 12,576.29	\$ 12,576.29	\$ 12,576.29	\$ 12,576.29	\$ 12,576.29	\$ 12,576.29	\$ 12,576.29	\$ 12,576.29	\$ 12,576.29	Reg up and Reg down - based on Caiso_Exp Prices
Spinning Revenue (\$)	(not used in calculations)	\$ -	\$ -	\$ -	\$ -	\$ -	\$ -	\$ -	\$ -	\$ -	\$ -	All energy to Reg b/c higher pricing
Resource Adequacy [200kW] (\$/kW/y)	\$ 4.75	\$ 11,400.00	\$ 11,400.00	\$ 11,400.00	\$ 11,400.00	\$ 11,400.00	\$ 11,400.00	\$ 11,400.00	\$ 11,400.00	\$ 11,400.00	\$ 11,400.00	Based on "2018 RA Report" - 85th percentile local RA for PG&E (\$4.75)
Additional operation cycle (CAISO AS)	(not used in calculations)	\$ 2,647.77	\$ 2,647.77	\$ 2,647.77	\$ 2,647.77	\$ 2,647.77	\$ 2,647.77	\$ 2,647.77	\$ 2,647.77	\$ 2,647.77	\$ 2,647.77	<- Requires second battery charge cycle - not worth it (not included in calculations)
Demand Response	(not used in calculations)	\$ -	\$ -	\$ -	\$ -	\$ -	\$ -	\$ -	\$ -	\$ -	\$ -	DR conflicts with higher value ancillary services
Total Ancillary Revenues		\$ 23,976.29	\$ 23,976.29	\$ 23,976.29	\$ 23,976.29	\$ 23,976.29	\$ 23,976.29	\$ 23,976.29	\$ 23,976.29	\$ 23,976.29	\$ 23,976.29	
Total Revenues		\$ 44,972.48	\$ 44,878.41	\$ 44,580.77	\$ 44,287.36	\$ 43,998.13	\$ 43,713.02	\$ 43,431.97	\$ 43,154.92	\$ 42,881.82	\$ 42,612.60	
Project Operational Expenses												
Scheduling Coordinator Rate (\$/Month)	\$ 2,400.00	\$ 2,400.00	\$ 2,400.00	\$ 2,400.00	\$ 2,400.00	\$ 2,400.00	\$ 2,400.00	\$ 2,400.00	\$ 2,400.00	\$ 2,400.00	\$ 2,400.00	Multiple Quotes - starting at \$3k/month
Coordinated group size (kW, <=10k)	1,000	\$ 1,200.00	\$ 1,200.00	\$ 1,200.00	\$ 1,200.00	\$ 1,200.00	\$ 1,200.00	\$ 1,200.00	\$ 1,200.00	\$ 1,200.00	\$ 1,200.00	Max charge assuming no SC aggregation
Scheduling Coordinator Capacity Fee (\$/mo/kWh)	\$ 0.20	\$ 219.20	\$ 219.20	\$ 219.20	\$ 219.20	\$ 219.20	\$ 219.20	\$ 219.20	\$ 219.20	\$ 219.20	\$ 219.20	
Scheduling Coordinator Expense (\$ per year)	Annual Total	\$ 17,030.40	\$ 17,030.40	\$ 17,030.40	\$ 17,030.40	\$ 17,030.40	\$ 17,030.40	\$ 17,030.40	\$ 17,030.40	\$ 17,030.40	\$ 17,030.40	
Market Expenses												
Wholesale Purchase Price (\$/MWh)	Selected mid-day hours	\$ 29.06	\$ 29.65	\$ 30.24	\$ 30.84	\$ 31.46	\$ 32.09	\$ 32.73	\$ 33.39	\$ 34.05	\$ 34.73	
Electricity Purchased (MWh)		360	351	343	335	327	319	311	304	296	289	365 cycles * 90% utilization of 1096 kWh capacity * 2.4% annual degradation
Wholesale Purchase Cost (\$)		\$ 10,464.13	\$ 10,417.26	\$ 10,370.59	\$ 10,324.13	\$ 10,277.87	\$ 10,231.83	\$ 10,185.99	\$ 10,140.36	\$ 10,094.93	\$ 10,049.70	
Net Market Revenues		\$ 17,477.94	\$ 17,430.76	\$ 17,179.78	\$ 16,932.83	\$ 16,689.86	\$ 16,450.79	\$ 16,215.58	\$ 15,984.16	\$ 15,756.49	\$ 15,532.50	
Operational Expenses												
Site Lease	\$0k/mo	\$ -	\$ -	\$ -	\$ -	\$ -	\$ -	\$ -	\$ -	\$ -	\$ -	
Site O&M	\$4.2k/year	\$ 4,200.00	\$ 4,200.00	\$ 4,200.00	\$ 4,200.00	\$ 4,200.00	\$ 4,200.00	\$ 4,200.00	\$ 4,200.00	\$ 4,200.00	\$ 4,200.00	
Site Maintenance	\$400/mo	\$ 4,800.00	\$ 4,800.00	\$ 4,800.00	\$ 4,800.00	\$ 4,800.00	\$ 4,800.00	\$ 4,800.00	\$ 4,800.00	\$ 4,800.00	\$ 4,800.00	
Internet	\$100/mo	\$ 1,200.00	\$ 1,200.00	\$ 1,200.00	\$ 1,200.00	\$ 1,200.00	\$ 1,200.00	\$ 1,200.00	\$ 1,200.00	\$ 1,200.00	\$ 1,200.00	
Total Expenses (\$)		\$ 37,694.53	\$ 37,647.66	\$ 37,600.99	\$ 37,554.53	\$ 37,508.27	\$ 37,462.23	\$ 37,416.39	\$ 37,370.76	\$ 37,325.33	\$ 37,280.10	
Net Total Operational Cash Flow (\$)	*	\$ 7,277.94	\$ 7,230.76	\$ 6,979.78	\$ 6,732.83	\$ 6,489.86	\$ 6,250.79	\$ 6,015.58	\$ 5,784.16	\$ 5,556.49	\$ 5,332.50	
Project Owner Cash Flows												
Project Revenues		\$ 7,277.94	\$ 7,230.76	\$ 6,979.78	\$ 6,732.83	\$ 6,489.86	\$ 6,250.79	\$ 6,015.58	\$ 5,784.16	\$ 5,556.49	\$ 5,332.50	
Cap Ex (total installed cost of storage facility)	\$ 1,710,942	\$ 1,710,942	\$ 1,710,942	\$ 1,710,942	\$ 1,710,942	\$ 1,710,942	\$ 1,710,942	\$ 1,710,942	\$ 1,710,942	\$ 1,710,942	\$ 1,710,942	
Cap Ex repayment (est.)	\$ 1,710,942	\$ 124,415.64	\$ 124,415.64	\$ 124,415.64	\$ 124,415.64	\$ 124,415.64	\$ 124,415.64	\$ 124,415.64	\$ 124,415.64	\$ 124,415.64	\$ 124,415.64	20 yr loan @ 4% interest
VGES Net Cap Ex after CEC grant		\$ 1,400,872	\$ 1,018,688.00	\$ 1,018,688.00	\$ 1,018,688.00	\$ 1,018,688.00	\$ 1,018,688.00	\$ 1,018,688.00	\$ 1,018,688.00	\$ 1,018,688.00	\$ 1,018,688.00	20 yr loan @ 4% interest
Net Cap Ex repayment (est.)	\$ 1,400,872	\$ 101,868.00	\$ 101,868.00	\$ 101,868.00	\$ 101,868.00	\$ 101,868.00	\$ 101,868.00	\$ 101,868.00	\$ 101,868.00	\$ 101,868.00	\$ 101,868.00	annualized cost of replacement @ year 15, assuming 50% cost reduction from 2020 cost basis
Replacement cell cost (2.4% annual degradation)	\$ 428,891	\$ 14,296.37	\$ 14,296.37	\$ 14,296.37	\$ 14,296.37	\$ 14,296.37	\$ 14,296.37	\$ 14,296.37	\$ 14,296.37	\$ 14,296.37	\$ 14,296.37	annualized cost of replacement @ year 15, assuming 2020 cost basis
Replacement inverter (15yr)	\$ 100,000	\$ 6,666.67	\$ 6,666.67	\$ 6,666.67	\$ 6,666.67	\$ 6,666.67	\$ 6,666.67	\$ 6,666.67	\$ 6,666.67	\$ 6,666.67	\$ 6,666.67	
Net Project Owner Cash Flow												
Added - interconnection upgrade cap ex:												
New Transformer	\$ 86,263											
Recloser	\$ 87,500											
Cost of Ownership charge underground vault	\$ 142,124											
	\$ 56,736											
Total	\$ 372,623											