

Comment Received From: Michael Ivanovich
Submitted On: 4/29/2022
Docket Number: 22-AAER-01

AMCA Publication 211-22 - in whole - to supplement AHRI-AMCA and AMCA-AHRI-NEEA Comments

Please find attached to this comment the complete AMCA 211-22 Certified Ratings Program Product Rating Manual for Fan Air Performance, which supports the AHRI-AMCA Joint Comment to the NOPA Proposed Regulatory Language, and the Joint Comments submitted by AMCA, AHRI, and NEEA.

AMCA makes this document available at no cost from its online store at www.amca.org/store, and is providing it to the docket for convenience.

Additional submitted attachment is included below.

AMCA 211-22

Certified Ratings Program Product Rating Manual for Fan Air Performance



Air Movement and Control Association International

AMCA Corporate Headquarters

30 W. University Drive, Arlington Heights, IL 60004-1893, USA
communications@amca.org | Ph: +1-847-394-0150 | www.amca.org

© 2022 Air Movement & Control Association International, Inc.

AMCA Publication 211-22

Certified Ratings Program Product Rating Manual for Fan Air Performance



Air Movement and Control Association International
30 West University Drive
Arlington Heights, Illinois
60004

AMCA Publications

Authority AMCA Publication 211-22 was adopted by the membership of the Air Movement and Control Association International Inc. on January 11, 2022.

Copyright © 2022 by the Air Movement and Control Association International Inc.

All rights reserved. Reproduction or translation of any part of this work beyond that permitted by sections 107 and 108 of the United States Copyright Act without the permission of the copyright owner is unlawful. Requests for permission or further information should be addressed to the executive director, Air Movement and Control Association International Inc. at 30 West University Drive, Arlington Heights, IL 60004-1893, U.S.A.

Objections The Air Movement and Control Association (AMCA) International Inc. will consider and take action upon all written complaints regarding its standards, certification programs or interpretations thereof. For information on procedures for submitting and handling complaints, write to:

AMCA International
30 West University Drive
Arlington Heights, IL 60004-1893
U.S.A.

European AMCA
Avenue de Tervueren 188a
Postbox 4
1150 Brussels, Belgium

Asia AMCA Sdn Bhd
No. 7, Jalan SiLC 1/6,
Kawasan Perindustrian SiLC Nusajaya,
Mukim Jelutong, 79200 Nusajaya, Johor
Malaysia

Disclaimer AMCA uses its best efforts to produce publications for the benefit of the industry and the public in light of available information and accepted industry practices. However, AMCA does not guarantee, certify or assure the safety or performance of any products, components or systems tested, designed, installed or operated in accordance with AMCA publications or that any tests conducted under its publications will be non-hazardous or free from risk.

Review Committee

Voting Members

Rad Ganesh, Chair
Armin Hauer, Vice Chair
Adam Sterne
Dave Johnson
Christian Taber
Nathan Fetting
Josh Felver
Aaron Saldanha
Bob Valbracht
Frank Cuaderno
Andy Timm
Kim Osborn
Ola Wettergren
Yong Ning Chen

Company/Affiliation

Twin City Fan Companies Ltd.
ebm-papst Inc.
Acme Engineering & Manufacturing Corp.
Berner International LLC
Big Ass Fans
Greenheck Fan Corp.
Hartzell Air Movement
Howden Americas
Loren Cook Co.
Mars Air Systems
The New York Blower Co.
Nortek Air Solutions
Systemair Manufacturing Inc.
Zhejiang Yilida Ventilator Co. Ltd.

Non-Voting Members

Abhishek Jain
Brian Mleziva

Company/Affiliation

Air Flow Pvt. Ltd.
Greenheck Fan Corp.

Staff

Joe Brooks, Staff Liaison

AMCA International Inc.

Contents

Preface	viii
Certified Ratings Program—Product Rating Manual for Fan Air Performance	1
1. Purpose and Scope.....	1
2. Normative References.....	1
3. Definitions.....	2
4. Data Submittal Requirements	4
5. Drive Methods.....	5
6. Ducted Inlet Simulation	5
7. Catalog Requirements	5
7.1 Scope of certification	5
7.2 Statement required adjacent to the AMCA Certified Ratings Program seals	5
7.3 Application statements.....	6
7.4 Noncertified FEI, CFEI, FEG and/or sound ratings	6
7.5 The AMCA Certified Ratings Program seals	6
8. Fan Performance Ratings.....	6
8.1 Manufacturer’s responsibility	6
8.2 AMCA International staff’s responsibility.....	7
8.3 Ratings development.....	7
8.4 Catalog data	11
8.5 Alternate performance determination methods (APDM)	11
8.6 Alternate electrical input determination method (AEDM)	12
8.7 Alternate testing determination methods (ATDM)	12
9. Ratings Method Details.....	13
9.1 Rating method A/B/D: Centrifugal, mixed-flow, axial, propeller fans, power roof ventilators (PRVs), energy recovery ventilator (ERVs) and axial impellers (constant speed rating method).....	13
9.2 Rating method C/E: centrifugal, mixed-flow, axial, propeller fans, PRVs, ERVs, axial impellers and single room air handlers (as-run speed rating method)	15
9.3 Rating method F: Centrifugal, mixed-flow, axial, propeller fans, PRVs, ERVs, axial impellers and single room air handlers	16
9.4 Rating method G: Air curtains.....	17
9.5 Rating method H: Jet fans	19
9.6 Rating method I: Agricultural ventilation fans	20
9.7 Rating method J: PPVs	21
9.8 Rating method K: Circulating fans	21
9.9 Rating method L: Induced flow fans	22
9.10 Rating method M: Residential ventilating fans	23
9.11 Rating method N: Large-diameter ceiling fans	25
10. Check Tests.....	26
10.1 Centrifugal, mixed-flow, axial, propeller and agricultural fans, PRVs, PPVs and ERVs	26
10.2 Air curtains	31
10.3 Jet fans	31
10.4 Circulating fans.....	32

10.5 Induced flow fans.....	32
10.6 PDS	32
11. Product Rating Requirements for Centrifugal and Mixed Flow Fans	33
11.1 Product configuration.....	33
11.2 Test conditions	33
11.3 Test data submittal requirements	34
12. Product Rating Requirements for Axial Fans	34
12.1 Product configuration.....	34
12.2 Test conditions	35
12.3 Test data submittal requirements	35
12.4 Precertification check tests.....	35
13. Product Ratings Requirements for Propeller Fans	35
13.1 Product configuration.....	35
13.2 Test conditions	36
13.3 Test data submittal requirements	36
14. Product Ratings Requirements for PRVs	36
14.1 Product configurations.....	36
14.2 Test conditions	37
14.3 Test data submittal requirements	37
14.4 Exhaust/supply units.....	37
15. Product Ratings Requirements for Jet Fans	38
15.1 Test setups	38
15.2 Product configuration.....	38
15.3 Test conditions	38
15.4 Test data submittal requirements	38
16. Product Ratings Requirements for Air Curtains	38
16.1 Conformance to standards	38
16.2 Product configuration.....	39
16.3 Test conditions	39
16.4 Test data submittal requirements	39
17. Product Ratings Requirements for Agricultural Ventilation Fans	40
17.1 Product configuration.....	40
17.2 Catalog photographs or illustrations	40
17.3 Test conditions	40
17.4 Test data submittal requirements	41
17.5 Alternate motors	41
18. Product Ratings Requirements for Positive Pressure Ventilators	41
18.1 Test setups.....	41
18.2 Product configuration.....	41
18.3 Catalog photographs or illustrations	42
18.4 Test conditions	42
18.5 Test data submittal requirements	42
18.6 Alternate motors/engines	42

- 19. Product Ratings Requirements for ERVs/HRVs 42**
 - 19.1 Definitions 42
 - 19.2 Test conditions 43
 - 19.3 Catalog requirements 43
- 20. Product Ratings Requirements for Circulating Fans 44**
 - 20.1 Test setups 44
 - 20.2 Product configuration or examples of installation 44
 - 20.3 Test conditions 44
 - 20.4 Test data submittal requirements 45
- 21. Product Ratings Requirements for Induced Flow Fans 45**
 - 21.1 Basic conditions 45
 - 21.2 Test setups 45
 - 21.3 Electrical power requirements 45
 - 21.4 Test data submittal requirements 45
- 22. Product Ratings Requirements for Large-Diameter Ceiling Fans 45**
 - 22.1 Test setups 45
 - 22.2 Product configuration or examples of installation 46
- Annex A Dimensional Requirements (Normative) 48**
 - A.1 General requirements 48
- Annex B CRP Forms (Informative) 63**
- Annex C Electronic Catalogs (Normative) 64**
 - C.1 Introduction 64
 - C.2 Scope 64
 - C.3 Allowable performance modifications 64
 - C.4 Required qualifying statements 65
 - C.5 Certification of electronic performance data 67
 - C.6 Version numbers 67
 - C.7 Identifying certified performance 67
 - C.8 AMCA International directory listings 68
- Annex D Guidelines for Development of Fan Performance Ratings (Informative) 69**
 - D.1 Introduction 69
 - D.2 Similarity 69
 - D.3 Compressibility 69
 - D.4 Test fan sizes and test speeds 70
 - D.5 Power transmission losses 71
- Annex E Reference Material (Informative) 73**
- Annex F Summary of Available Ratings Methods (Informative) 74**
- Annex G Labeling Requirements for Fans with a Regulated Motor and/or Certified FEI (Normative) 75**
 - G.1 Scope 75
 - G.2 Information required 75
 - G.3 Performance map requirements 75
 - G.4 Label's physical requirements 76
- Annex H Fan Electrical Input Power with Unregulated Motors and Controllers (Normative) 78**

H.1 General	78
H.2 PDS testing	79
H.3 Lab requirements and instrumentation	79
H.4 Test conditions	79
H.5 Test report.....	79
H.6 Speed and load points	79
Annex I Calculation Methods for Determining Fan Performance Ratings (Normative)	82
I.1 Scope.....	82
I.2 Symbols and subscripts.....	82
I.3 Compressibility	83
I.4 Fan laws (extrapolation)	84
I.5 Interpolation based on fan speed	85
I.6 Interpolation based on fan diameter	87
I.7 General dimensional interpolation between tested fans	90

Preface

This edition of AMCA Publication 211, *Certified Ratings Program, Product Rating Manual for Fan Air Performance*, incorporates many major changes to the AMCA International Certified Ratings Program for fans. Many of the changes resulted from experiences gained over the past several years with some of the changes originating with the AMCA International's Fan Committee. Other changes were developed to support and anticipate foreseeable government regulations. All changes were made keeping the needs of the industry in mind along with the needs of the public.

AMCA Publication 211, has been in committee since October 2018. The last revision focused on the introduction of FEI certification into 211. The utility and adoption of FEI is a key strategy for AMCA, with pending regulation referencing this efficiency metric.

This edition of AMCA 211 contains major changes that strategically align AMCA members with their customers and various other regulatory bodies. A summary of these major changes, why they were made and their impact on licensees of the AMCA International Certified Rating Program follow:

1. Changes to AMCA 211-18 check Test Tolerances in Section 10:

A. What changed:

- i. Check test tolerances will be applied to each test point individually as opposed to the entire fan curve at once.
- ii. Each test point will individually have a +/- 5% tolerance on speed to achieve the Point of Rating (POR) while not exceeding 7.5% tolerance on the POR power for shaft-to-air ratings and 10% tolerance on POR power for wire-to-air ratings.

B. Reason for change:

- i. Provides consistency with AHRI 430 tolerances as both are closely aligned.
- ii. Aligns testing validation with field installation and application of fans.
- iii. Regulators will test performance to a Point of Rating, POR (duty point, design point) of airflow, power consumption and static or total pressure.
- iv. Customers in the field can fine tune performance using speed change (VFD or sheave/belts) to achieve desired POR.
- v. With the current check test tolerances, a certified fan (if not certified for efficiency) could have up to a 13% lower than published efficiency in its performance rating and can still pass a test. It was understood in the committee that pending state and federal fan-efficiency regulations would require stricter check test tolerances. The intent is that the new changes will closer align with acceptance of regulators and they will therefore reference this standard and bring stronger reliability to AMCA's Certified Ratings Program.
- vi. Open market test tolerances are aligned with the same methodology, but at a greater tolerance than if supplied directly by the manufacturer.
- vii. During its approval phase, some concerns were shown for products that have been certified over many years without any performance issues (including check tests). These fans may only need a catalog change to meet the new requirements. For currently certified fans, such catalog changes will not be required for three years after final Board approval of this revised publication so that member companies may comply. For new certified products, the requirements would go into effect the first of the month after final Board approval.
- viii. During a check test of a fan certified prior to Final Approval of AMCA 211, if a fan fails using the new check test tolerance and would have passed using the old check test tolerance, and the licensee chooses to re-catalog, the licensee shall re-catalog based on the check test performance. The fan will then be called with normal periodicity, i.e. within 36 months. The normal requirement of a check test within 1 year shall be waived.

2. New Annex I on Speed and Diameter Interpolation:

A. What changed:

- i. Smallest size and lowest speed shall be tested. Fan laws can only be used for 'upward' speed and diameter scaling when one fan speed is tested.
- ii. Diameter and speed interpolation from base test to scaled tests are allowed for catalog data when multiple fan speeds are tested.

B. Reason for change:

- iii. To provide better accuracy for low-speed fan performance.
- iv. Interpolation better reflects accuracy of smooth efficiency transitions from small to large size fans rather than 'step' transitions that were resulting from pure Fan laws calculations.
- v. All rating methods were consistently applied for wire-to-air and shaft-to-air performance.

3. Alternate Test Determination Methods (ATDMs) in Section 8.7:

A. What changed:

- i. This method allows extension of rating factor approach to various pressure loss accessories of a fan like hoods, stack caps, dampers, filters, nozzles, evasés etc. Rating factors shall be verified via precertification tests for 'non-tested' configurations.

B. Reason for change:

- ii. This approach minimizes testing burden for manufacturers by utilizing advanced modeling and simulation techniques in fan design.

4. Testing and Calibrating Power Drive Systems (PDS) for air performance / FEI certification in Section 10.6:

A. What changed:

- i. Requirements for testing PDS have been added to the CRP.

B. Reason for change:

- ii. Ultimately this total system energy consumption is what the market, our customers and regulators seek.
- iii. This feature enables fan manufacturers to mix and match the performance of PDS (wire-to-shaft) with their fans (shaft-to-air) to create Certified Ratings of Fan/Motor/Drive Systems that could exceed default AMCA 207/208 performance.
- iv. If Sound Power Levels (L_w) are acquired for a PDS, they can be also combined with fan L_{wo} , L_{wi} to determine and certify noise levels for complete fans with motors and drives.

5. Large Diameter Ceiling Fan (LDCF) modification to comply with revised US Federal Regulations in Section 8.3.9.3 and 9.11

6. Added Jet Fan and LDCF seals to better differentiate the distinct types of fan rating programs.

7. Clarified the definition of a "product line" (included examples) and added a definition of a "model" in Section 3.

A. What changed:

- i. Specifically added information regarding product line differentiation for propeller fans.

B. Reason for change:

- ii. This clarification may cause some propeller fan product lines to split into more than one product line. This change will help level the playing field for all member companies.
- iii. All product nomenclature, marketing literature and selection program implementation shall be up to the discretion of the fan manufacturers.
- iv. The 'product line' interpretation by AMCA shall go into effect three (3) years after Board approval of this revised publication. This change may affect member companies' catalogs, selection programs, number of products called for check tests and check test scheduling. The three (3) year period will allow member companies to assess the business impact for compliance.

- 8. Deleted certification of efficiency due to its very limited usage since its inception in 2005. Adoption of FEI by regulatory bodies negates the need for efficiency certification.**
- 9. Manufacturers shall be permitted to assume the compressibility ratio is equal to 1 if the fan total pressure is less than 2,500 Pa (10 in. wg) at any fan air density as outlined in Annex I.**

Certified Ratings Program—Product Rating Manual for Fan Air Performance

1. Purpose and Scope

The purpose of this manual is to prescribe technical procedures to be used in connection with the AMCA Certified Ratings Program for fan air performance.

Products that can be certified by AMCA to bear the AMCA certified ratings seals are those defined in ANSI/AMCA Standard 99, Section 0068; ISO 13349; and IEC 60335-2-80 and are within the product scope of AMCA International.

The program applies only to fans and axial impellers.

2. Normative References

AMCA Publication 11, *Certified Ratings Program Operating Manual*, Air Movement and Control Association International Inc., Arlington Heights, IL USA.

ANSI/AMCA Standard 99, *Standards Handbook*, Air Movement and Control Association International Inc., Arlington Heights, IL USA.

AMCA Publication 111, *Laboratory Accreditation Program*, Air Movement and Control Association International Inc., Arlington Heights, IL USA.

AMCA Publication 200, *Air Systems*, Air Movement and Control Association International Inc., Arlington Heights, IL USA.

AMCA Publication 311, *Certified Ratings Program Product Rating Manual for Fan Sound Performance*, Air Movement and Control Association International Inc., Arlington Heights, IL USA.

ANSI/AHRI Standard 1210, *Performance Rating of Variable Frequency Drives*, Air-Conditioning, Heating, and Refrigeration Institute, 2311 Wilson Blvd, Suite 400, Arlington, VA 22201-3001 U.S.A

ANSI/AMCA Standard 205, *Energy Efficiency Classification for Fans*, Air Movement and Control Association International Inc., Arlington Heights, IL USA.

ANSI/AMCA Standard 207, *Fan System Efficiency and Fan System Input Power Calculation*, Air Movement and Control Association International Inc., Arlington Heights, IL USA.

ANSI/AMCA Standard 208, *Calculation of the Fan Energy Index*, Air Movement and Control Association International Inc., Arlington Heights, IL USA.

ANSI/AMCA Standard 210, *Laboratory Methods of Testing Fans for Certified Aerodynamic Performance Rating*, Air Movement and Control Association International Inc., Arlington Heights, IL USA.

ANSI/AMCA Standard 220, *Laboratory Methods of Testing Air Curtain Units for Aerodynamic Performance Rating*, Air Movement and Control Association International Inc., Arlington Heights, IL USA.

ANSI/AMCA Standard 230, *Laboratory Methods of Testing Air Circulating Fans for Rating and Certification*, Air Movement and Control Association International Inc., Arlington Heights, IL USA.

ANSI/AMCA Standard 240, *Laboratory Methods of Testing Positive Pressure Ventilators for Aerodynamic Performance Rating*, Air Movement and Control Association International Inc., Arlington Heights, IL USA.

ANSI/AMCA Standard 250, *Laboratory Methods of Testing Jet Tunnel Fans for Performance*, Air Movement and Control Association International Inc., Arlington Heights, IL USA.

ANSI/AMCA Standard 260, *Laboratory Methods of Testing Induced Flow Fans for Rating*, Air Movement and Control Association International Inc., Arlington Heights, IL USA.

ANSI/AMCA Standard 300, *Reverberant Room Methods for Sound Testing of Fans*, Air Movement and Control Association International Inc., Arlington Heights, IL USA.

ANSI/ASHRAE Standard 222, *Standard Method of Test for Electrical Power Drive Systems*, ASHRAE, 180 Technology Parkway NW, Peachtree Corners, Georgia 30092 USA

CAN/CSA C838, *Energy efficiency test methods for three-phase variable frequency drive systems*, CSA Group, 178 Rexdale Blvd., Toronto, ON, Canada M9W 1R3

CAN/CSA C747, *Energy efficiency test methods for small motors*, CSA Group, 178 Rexdale Blvd., Toronto, ON, Canada M9W 1R3

HVI Publication 916, *Air Flow Test Procedure*, Home Ventilating Institute, 1740 Dell Range Blvd., Ste. H, PMB 450, Cheyenne, WY 82009 USA

IEC 60335-2-80, *Household and similar electrical appliances – Safety-Part 2-80: Particular requirements for fans*, International Electrotechnical Commission, 3 rue de Varembe, PO Box 131, CH-1211 Geneva 20, Switzerland

IEEE 112-96, *Test Procedure for Polyphase Induction Motors and Generators*, IEEE Standards Association, 501 Hoes Lane Piscataway, NJ 08854-4141 USA

ISO 5801, *Industrial Fans — Performance Testing Using Standardized Airways*, International Organization for Standardization, Geneva, Switzerland.

ISO 13349:2010 – *Fans – Vocabulary and definitions of categories*, International Organization for Standardization, Geneva, Switzerland.

ISO 13350, *Fans – Performance Testing of Jet Fans*, International Organization for Standardization, Geneva, Switzerland.

ISO/IEC 17025, *Testing and calibration laboratories* 10 CFR Part 429, Subpart B – *Certification*, International Organization for Standardization, Geneva, Switzerland.

10CFR Part 430, Subpart B, Appendix U – *Uniform Test Method for Measuring the Energy Consumption of Ceiling Fans* 42 U.S. Code 6295 – Energy Conservation Standards

U.S. Environmental Protection Agency's ENERGY STAR program requirements, *Product Specification for Residential Ventilating Fans*, Eligibility Criteria (found on the ENERGY STAR website, www.energystar.gov).

3. Definitions

All definitions in AMCA Publication 11, ANSI/AMCA Standard 99, as well as the following, apply to this program:

3.1 AMCA Certified Ratings Program air performance

A program for certifying a product's aerodynamic performance ratings, as defined in this document.

3.2 Appurtenance

Any item in or on the inlet or discharge airstream that affects the performance of the fan. An accessory is henceforth referred to as an appurtenance.

3.3 As-run speed

The test results are reported at the fan test speed.

3.4 Axial impeller

An impeller in which airflow enters and exits substantially parallel to the shaft axis, designed to operate in an orifice, partition or bell-mouth structure. See Figure A.38 for mandatory dimension reporting requirements.

See Section 13.1.4 for a sampling of different propeller shapes that shall constitute a method of differentiating product lines.

3.5 Ceiling fan energy index (CFEI)

A ratio of the electrical input power of a reference ceiling fan to the electrical input power. CFEI is calculated in accordance with ANSI/AMCA Standard 208, with the modifications listed in Section 8.3.9.3.3.

3.6 Constant speed

Test data are converted to a single speed before catalog data are generated.

3.7 Fan efficiency grade (FEG)

A metric defined by ANSI/AMCA Standard 205 that represents an efficiency grade for fans without consideration of the drives.

3.8 Fan energy index (FEI)

A ratio of the electrical input power of a reference fan to the electrical input power as defined by ANSI/AMCA Standard 208.

3.9 Free inlet

Without a duct on the inlet.

3.10 Free outlet

Without a duct on the outlet.

3.11 Model

A product line subdivision that identifies unique physical attributes that result in varied performance from other products in the line. For example, size is a common attribute that would distinguish a model in a product line. Optional appurtenances would not be considered as separate models.

3.12 Performance rating(s)

A statement of the pressure performance and power vs. airflow at a given speed at standard inlet air density or other specified density. Efficiency also may be included in the performance ratings at the option of the licensee. Power shall be specified as impeller, shaft or electrical input power as appropriate. The rating may be published in tabular and/or graphical format. Specific performance rating requirements are given in the product rating requirements sections of this document.

3.13 Power drive system (PDS)

An adjustable speed electric alternating current (AC) PDS, which includes a complete drive module and motor.

3.14 Product line

A series of fan models with a common design purpose and similar aerodynamic features (or an individual product where only one size is offered for sale) that are cataloged under the same product description name and/or identifying reference and are within this program's scope. Significant differences in blade construction, for example, a change from single thickness to airfoil blade or different blade shapes shall constitute different product lines. Figures 3a – 3d show examples of designs that shall constitute different product lines. Modifications that do not differentiate product lines may include changes in pitch angle at a designated radius, hub-to-tip ratio or solidity (number of blades).

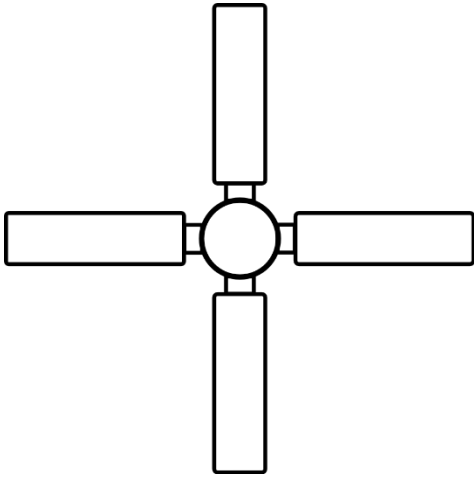

Figure 3a - Straight Blade

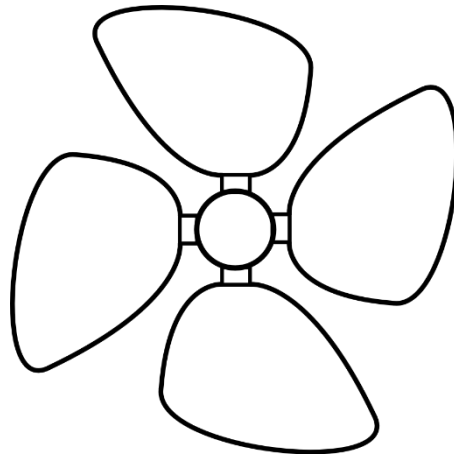

Figure 3b - Paddle Blade

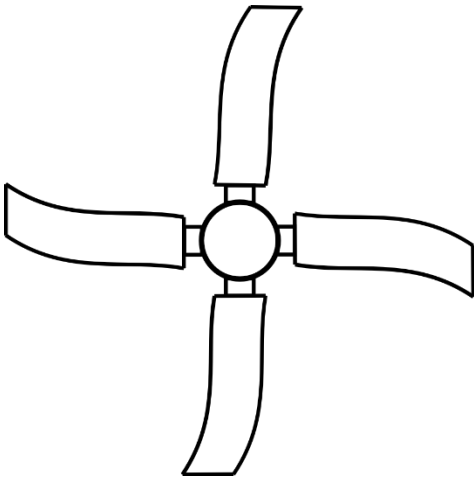

Figure 3c - Forward/Backward Swept

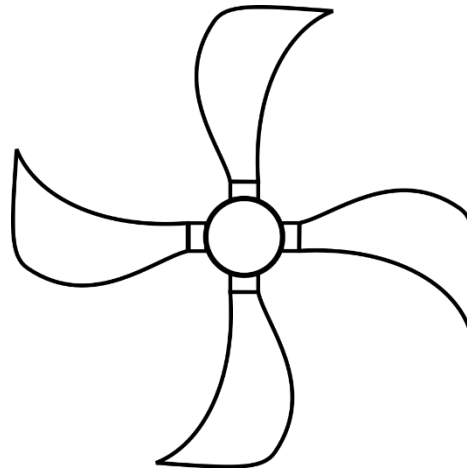

Figure 3d - Sickle Blade

3.15 Shall and should

The word *shall* is understood to be a mandatory requirement, and the word *should* is understood to be advisory.

3.16 Single room air handler

An enclosed assembly consisting of a fan(s) and at least one electric motor. It may include additional components to condition and/or control the air. Only single inlet/outlet testing may be used for ratings.

4. Data Submittal Requirements

The following data shall be submitted with the CRP-8 application form:

- Test data for each test conducted (observations of all variables measured for each test point), which must conform to the test standard used.
- Results of the test(s) converted to standard air density and constant speed, where applicable.
- Drawings of each size of the product line, showing the dimensions specified in Annex A for the type of product being submitted.
- Photograph of each test setup.

5. Drive Methods

Various methods may be used to drive the test unit and measure the power input to the fan. The power measurements may or may not include the power transmission losses, but for fans supplied with shaft and bearings, the bearing losses shall be included in the fan power input measurement. See Annex D for more information about allowable methods of accounting for bearing and/or power transmission losses when calculating test data to other sizes and speeds.

Direct driven fans using “low-slip” motors (e.g., squirrel cage induction motors) may be driven by a dynamometer or a calibrated motor when the fan power rating is the output power of the dynamometer or calibrated motor. When the fan power rating is the motor input power, the fan shall be driven by its own motor. Direct driven fans using “high slip” motors (e.g., shaded pole or capacitor start motors) shall be driven by those motors, and the power rating shall be the motor input power.

Motor calibrations shall be performed by an AMCA laboratory, or a laboratory accredited for the appropriate motor test standard(s) under AMCA 111 or ISO 17025. Motor calibrations shall be performed at the voltage and frequency to be used for the fan test and shall be conducted at the motor’s operating temperature.

If fan systems include electric drivers (e.g., variable frequency drives [VFDs] or electronically commutated motors), then the input power is the electrical power consumed by the electric drive.

6. Ducted Inlet Simulation

Ducted inlet performance may be simulated by using an inlet bell or an inlet bell and one diameter of inlet duct.

7. Catalog Requirements

7.1 Scope of certification

This certified ratings program applies to fans within the scope of AMCA for which performance rating catalogs are published and made available to the public. When only a portion of a cataloged series of sizes are certified, a majority of the sizes cataloged shall be certified. It does not apply to special units for which performance ratings are not published. When performance ratings for both certified and non-certified products are contained in the same catalog, there must be a clear distinction made between them, as required in AMCA Publication 11, Section 11. The same requirement applies if some catalog performance data are not certified.

7.2 Statement required adjacent to the AMCA Certified Ratings Program seals

7.2.1 Certified products statement

In catalogs containing ratings of certified products, the following statement shall be printed prominently and immediately adjacent to the reproduction of the AMCA certified ratings seals, except as noted in Section 10.5 of AMCA Publication 11:

“[Licensee’s name] certifies that the [product description] shown herein [is/are] licensed to bear the AMCA seal. The ratings shown are based on tests and procedures performed in accordance with AMCA Publication 211 (and AMCA Publication 311 if sound is also certified) and comply with the requirements of the AMCA Certified Ratings Program.”

7.2.2 Additional FEI, CFEI and FEG statement requirements

In cases in which some models within a product line are FEI, CFEI or FEG certified, but others are not, provide the following statements in addition to the qualifying statement stated above:

“The AMCA Certified Ratings Program seal applies to air performance (and sound) for models [XXX] (or models on pages [XX-XX]) only.”

“The AMCA Certified Ratings Program seal applies to the [add as appropriate: FEI, CFEI, FEG] for models [XXX] (or models on pages [XX-XX]) only.”

7.3 Application statements

The qualifying statements required in the rating method details (sections 9.1 through 9.11) shall be shown immediately adjacent to the ratings, not with the seal.

7.4 Noncertified FEI, CFEI, FEG and/or sound ratings

Where noncertified FEI, CFEI, FEG and/or sound ratings are shown adjacent to the certified air performance ratings, the following statement shall be shown prominently adjacent to the noncertified ratings:

“The AMCA certified ratings seal applies to air performance [add as appropriate: sound, FEI, CFEI, FEG ratings] only.”

7.5 The AMCA Certified Ratings Program seals

All AMCA Certified Ratings Program seals can be seen on the AMCA website (www.amca.org)

7.5.1 FEG seal usage

7.5.1.1 All models FEG certified

Use the AMCA sound and air performance seal, AMCA FEG seal or AMCA air performance FEG seal, whichever is applicable, with the qualifying statement, as usual. The blue and yellow AMCA seal also may be used if desired.

7.5.1.2 Some models FEG certified

Use the AMCA sound and air performance seal or AMCA air performance seal, whichever is applicable, for models not AMCA certified for FEG. Additionally, use the AMCA sound and air performance FEG seal, AMCA air performance FEG seal or generic FEG seal for models that are AMCA certified. See Section 7.2.2 for additional statement requirements.

7.5.2 Certification/seal types

See Table 7.1 for seal types available for each certifiable product type

7.6 FEI label requirements

See Annex G regarding labeling requirements for fans with a regulated FEI.

7.7 Further information

See Section 9 for further information on qualifying statements and use of the AMCA Certified Ratings Program seals.

8. Fan Performance Ratings

8.1 Manufacturer's responsibility

The fan manufacturer is responsible for developing fan performance ratings for its production fans that perform within the tolerances established by the AMCA Certified Ratings Program as defined in Section 10. Separate product rating requirements sections define specific requirements for each type of product. Licensees shall certify their products based on test methods appropriate for the designed purpose of the fan (e.g., a jet fan cannot be certified based on a circulating fan test).

8.2 AMCA International staff's responsibility

AMCA International staff is responsible for the administration of the AMCA Certified Ratings Program by verifying that the manufacturer's air performance ratings were developed in accordance with the requirements of this program.

AMCA International staff is also responsible for verifying that the catalog published by the licensee conforms to the program requirements.

8.3 Ratings development

8.3.1 General requirements

The air performance rating of a fan or a series of similar fans is developed from tests conducted in accordance with ANSI/AMCA Standard 210, ISO 5801 or other testing standards recognized in AMCA Publication 111, using the same standardized airways.

The manufacturer is responsible for determining the product sizes to be tested and the number of tests that must be performed to provide the data necessary for the development of certified ratings.

8.3.2 Conversion formulae

Calculation to other sizes and speed will be performed in accordance with Annex I and the appropriate product rating sections.

8.3.3 Geometrically similar products

Products of different materials, such as steel vs. aluminum, or fiberglass vs. carbon fiber, where differences in thickness are small, shall be considered geometrically similar. Products using materials with large thickness or roughness variations, such as steel vs. fiberglass, are not considered similar. Where differences in thickness or roughness are large, the manufacturer shall demonstrate similarity through comparison testing. Refer to Annex D.

8.3.4 Appurtenances

An appurtenance should be considered a part of the fan if it is in place when the fan is tested for a performance rating, and the effect of the appurtenance is included in the cataloged performance rating.

Table 7.1 -- Seal Availability and Method of Test (MOT) Standards for Product Types

Product Types →	Centrifugal and mixed flow fans	Axial fans	PRVs	Prop fans	Air curtain Units	Circulating fans	Agricultural fans	Induced flow fans	PPVs	Jet fans	Large diameter ceiling fans	Axial props	Evaporative coolers	ERV/HRV	Ceiling ventilators
Seal Type															
Air	X	X	X	X	X							X	X	X	X
Sound & air	X	X	X	X	X								X	X	X
cfm/watt							X								X
cfm/watt, sound							X								X
PPV									X						
Circulating fan						X									
FEG, air	X	X	X	X											X
FEG, sound and air	X	X	X	X											X
Induced flow fan (IFF) air								X							
IFF air and sound								X							
IFF air and FEG								X							
IFF air, sound and FEG								X							
FEI, air	X	X	X	X			X								X
FEI, air, and sound															X
FEI, IFF air								X							
FEI, IFF air and sound								X							
Jet fan -thrust										X					
Jet fan -thrust and sound										X					
FEI, jet fan thrust & sound										X					
FEI, circulating fan						X									
LDCF air											X				
LDCF air & CFEI											X				
MOT Standard															
AMCA 210	X	X	X	X	X							X	X	X	X
ISO 5801	X	X	X	X	X										
AMCA 220					X										
AMCA 230						X					X				
AMCA 240									X						
AMCA 250										X					
ISO 13350										X					
AMCA 260								X		X					
AMCA 300	X	X	X	X	X					X					X
ISO 13347-2	X	X	X	X	X										X
AMCA 320	X	X	X	X											X
ISO 13347-4	X	X	X	X											X

A fan may include various appurtenances that affect its air performance, the effect of which may or may not be included in the fan's performance rating. Other appurtenances may affect the power absorbed, which also may or may not be included in the fan's performance rating.

8.3.5 Catalog performance rating

The performance rating is applicable only to the fan configuration tested, including any appurtenances tested with the fan. Statements of total (mechanical) or static efficiency may be included as part of the rating.

8.3.6 Bearings and shafts

If a fan impeller is provided with bearings, it shall be tested on its own shaft and bearings. The bearings shall be unmodified commercially available bearings but may be "run in" to simulate the losses occurring in practice.

8.3.7 Bi-stable operating region

When a fan shows a region of bi-stable operation in the certified range, the catalog data for that range shall be based upon tests that yield the lower pressure and corresponding power. The manufacturer shall inform AMCA if bi-stable operation for the fan is possible and if any appropriate requirements for the test procedures are known.

8.3.8 Published ratings

The catalog data published under the AMCA Certified Ratings Program shall contain the information listed for each rating method.

For all ratings methods, the following statement shall be shown immediately adjacent to the ratings tables, graphs or charts:

"Performance certified is for installation type (list one or more of the following types)."

- A. Free inlet, free outlet with partition
- B. Free inlet, ducted outlet
- C. Ducted inlet, free outlet
- D. Ducted inlet, ducted outlet
- E. Free inlet, free outlet without partition

8.3.9 Efficiency Metrics (FEG, FEI, CFEI)

8.3.9.1 FEG certification

Fan Efficiency Grades (FEGs) are based solely on fan total pressure. To be eligible to bear one of the AMCA FEG seals, the requirements detailed in sections 8.3.9.2.1 through 8.3.9.2.3 must be met.

8.3.9.1.1 Prerequisites and requirements

The air performance of the product line must be AMCA certified to obtain the AMCA Certified Ratings Program FEG seal. An entire product line or individual models within a product line may obtain FEG certification. A model that has its FEG certified may display the FEG rating (not the seal) on its nameplate. There is no minimum number of models required to be certified in each product line. All products that are certified to bear the AMCA Certified Ratings Program FEG seal shall be identified in AMCA's directory of certified products.

8.3.9.1.2 Eligibility

The following fan types in AMCA Publication 211 are ineligible to obtain the AMCA Certified Ratings Program FEG seal:

- Air curtain units
- Energy recovery ventilators (ERVs)/heat recovery ventilators (HRVs)
- Positive pressure ventilators (PPVs)

8.3.9.1.3 Determination of FEG

Certified FEGs are determined in accordance with ANSI/AMCA Standard 205. The data used in the determination of a model's FEG will be based on that its base test data as referenced in the product line's CRP-8 application form. If the base test data is not available or incomplete, the FEG will be based on the model's certified catalog performance.

If cataloged data is used and the only certified power is the maximum fan input power, the determination of that model's FEG shall be based on the base data that was used to generate the catalog data.

Note: As defined in ANSI/AMCA Standard 205, the FEG classification applies only to fans of 750 W (1 hp) or greater.

If an axial flow fan is certified in multiple pitches and the customer is able to change the pitch, the FEG is based on the peak total efficiency within the range of pitches certified.

8.3.9.1.4 FEG catalog requirements

FEGs shall be displayed either in the product line's approved catalog, listed in AMCA's directory of certified products or both. To be listed in the directory of certified products, written authorization must be received from the licensee. If listed in the directory of certified products, the peak fan total efficiency will be listed with that model's FEG.

8.3.9.2 FEI certification and scope

FEI values shall not be published for duty points below 125W air power (based on static pressure), and airflow below 2 m³/s (4238 cfm). If the air power is at or above 125W or if airflow is at or above 2 m³/s (4238 cfm), FEI values may be published.

To be eligible to bear one of the AMCA Certified Ratings Program FEI seals, the following requirements must be met.

8.3.9.2.1 Prerequisites

The air performance of the product line must be AMCA International certified. An entire product line or individual model within a product line may obtain FEI certification. See Annex G for more information.

8.3.9.2.2 Eligibility

The following fan types within AMCA Publication 211 are ineligible to obtain the AMCA Certified Ratings Program FEI seal:

- Air curtains
- PPVs
- Evaporative coolers
- Energy (or heat) recovery ventilators
- Large diameter ceiling fans
- Any fans not within the scope of ANSI/AMCA Standard 208

8.3.9.2.3 Calculation of FEI

Certified FEIs are calculated in accordance with ANSI/AMCA Standard 208. The published data of each model number shall include the following:

Choice of:

- "FEI calculation is based on default motor calculation in accordance with ANSI/AMCA Standard 208".
- Motor power and number of poles for regulated motor and motor controller capacity (if any). For example, "FEI calculation is based on 5 HP, 4 pole IE3 motor."
- Motor power, speed, and nominal efficiency for unregulated motor and motor controller capacity (if any). For example, "FEI calculation is based on 5HP, 1800 rpm, 89% efficient motor with 5 HP VFD".
- "FEI calculation is based on wire-to-air tests."

8.3.9.3 CFEI certification

To be eligible to bear the AMCA CFEI seal, the following requirements must be met:

8.3.9.3.1 Prerequisites

The air performance of the product line must be AMCA International certified. An entire product line or individual model within a product line may obtain CFEI certification.

8.3.9.3.2 Eligibility

Large diameter ceiling fans are eligible to obtain the AMCA CFEI certification seal:

8.3.9.3.3 Calculation of CFEI

Certified CFEIs are determined in accordance with ANSI/AMCA Standard 208, with the following modifications:

- (I) An airflow constant (Q_0) of 12.507 m³/s (26,500 cfm).
- (II) A pressure constant (P_0) of 0.6719 Pa (0.0027 in. wg).
- (III) A fan efficiency constant (η_0) of 42% .

8.3.10 Electrical input with unregulated motors and controllers

For determining electrical input power with unregulated motors and controllers, see Annex H.

8.3.11 Wire-to-air measurements: Calculations to other speeds and densities

For determining how to interpolate wire-to-air efficiencies, see Annex I.

8.4 Catalog data

All proposed catalog data is checked against the reference test data. The catalog data is considered satisfactory if it is within one-quarter of the equivalent check test tolerance. Conservative ratings may be cataloged.

8.5 Alternate performance determination methods (APDM)

As technologies advance in product design, proprietary methods are acceptable to establish product performance ratings. These methods can include computational fluid dynamics (CFD), empirical modeling techniques, a combination of testing and modeling or other advanced techniques. Performance data can be determined by any of these methods and submitted to AMCA International as part of the Certified Ratings Program.

8.5.1 APDM validation

To validate an APDM, a description of the method used must be provided to AMCA International per the member confidentiality agreement along with proposed rating data developed from the APDM. Precertification tests will be required as follows: Instead of a single comparison between the AMCA International testing laboratory (or independent laboratory) test data and the applicant's submitted test data, multiple tests at the AMCA International testing laboratory (or independent laboratory) will be compared with the applicant's APDM data. For every varied fan parameter in the APDM (e.g., axial blade pitch, number of blades, hub-to-tip ratio, centrifugal impeller width, etc.), all combinations of the maximum and minimum values of the parameter not tested by the licensee will be tested and compared with the predicted values. For example, if a licensee has developed an APDM for an axial fan line in which the blade pitch angle, number of blades and hub diameter vary for each size, then eight (2x2x2) fan tests would be required to validate the APDM.

For each fan, AMCA International shall choose a configuration of parameters not previously tested by the applicant. The fans will be tested and compared with the submitted APDM data.

8.5.1.1 Application of check test tolerances

Prior to the precertification tests, the applicant must submit to AMCA International all APDM data to be used for catalog certification. The check test tolerances as described in Section 10 shall be applied to each precertification test. If the tested performance is within the tolerances as described in Section 10, the APDM is accepted and the APDM results shall be used for the catalog performance check.

8.5.1.2 Precertification test failures

If any precertification test fails, the applicant will be informed and given the opportunity to inspect the fan for damage or defects. If any damage or defects are found, the applicant shall repair or correct the product and the test will be repeated. If no shipping damage occurred, the licensee shall modify the APDM and a new precertification fan(s) shall be selected and tested to validate the modified APDM. If the fan passes the retest the APDM is accepted. If it fails, the APDM is rejected and the applicant can choose to develop a new APDM; the process starts over with a new ratings data submittal and precertification test units.

8.5.2 Catalog checks for fans using APDM

The catalog checks performed for a product line using an APDM will employ either base tests, if applicable, or the APDM data submitted prior to the precertification tests.

8.6 Alternate electrical input determination method (AEDM)

This option shall specifically consider the wire-to-air electrical input metric, fan electrical input power (FEP) as defined in ANSI/AMCA Standard 207, to be used with fan-only ratings. The focus here is to consider AEDM methods that allow the certification of fans, motors and controls. Fan-only ratings are combined with motor and control performance ratings that are either provided by the motor/control manufacturer or tested in an AMCA International or ISO/IEC 17025 accredited laboratory.

8.6.1 AEDM validation

To validate the AEDM, a description of the method used must be provided to AMCA International per the member confidentiality agreement, along with the proposed ratings data developed from the AEDM. Precertification tests will be required as follows: Instead of a single comparison between the AMCA International testing laboratory (or independent laboratory) test data and the applicant's submitted test data, multiple tests at the AMCA International testing laboratory (or independent laboratory) shall be compared with the AEDM. Two tests per parameter shall be performed as follows, similar to the APDM approach for fans:

1. For every motor type and control in the AEDM (e.g., induction, permanent magnet, electronically commutated motor [ECM]) the maximum speed in cataloged range, or two speeds if a control is used (max, (max-speed range/2)), shall be tested and compared with the predicted FEP values. For example, if an applicant has developed an AEDM for an ECM, two speeds shall be required to validate it.
2. Combinations of the maximum and minimum values of the motor output power, not tested by the licensee, shall be tested and compared with the predicted FEP values.

For example, a total of eight (2x2x2) tests (two types of motors, two speeds, two motor output power ratings) shall be performed to validate the AEDM. FEP predictions from fan input power may be done using algorithms from ANSI/AMCA Standard 207 or other proprietary methods.

8.6.1.1 Application of check test tolerances

Prior to the precertification tests, the applicant must submit to AMCA International all AEDM data to be used for certification. The check test tolerances as described in Section 10 shall be applied to each precertification test. The tolerances for fan input power shall be applied to the FEP, as they are both "power" quantities. If the test is within the tolerances as described in Section 10, the AEDM is accepted and the predicted results shall be used for the catalog performance.

8.6.1.2 Precertification test failures

If any precertification test fails, the applicant will be informed and given the opportunity to inspect the fan for damage or defects. If any damage or defects are found, the applicant shall repair or correct the product and the test will be repeated. If no shipping damage occurred, the licensee shall modify the AEDM and a new precertification fan(s) shall be selected and tested to validate the modified APDM. If the fan passes the retest the AEDM is accepted. If the comparison fails, the AEDM is rejected and the applicant can choose to develop a new APDM; the process starts over with a new ratings data submittal and precertification test units.

8.6.2 Catalog checks for fans using AEDM

The catalog checks performed for a product line using an AEDM will employ base tests, if applicable, or the AEDM data submitted prior to the precertification tests.

8.7 Alternate testing determination methods (ATDM)

A certified product line may be used as the basis for a different product line when a modification is made, either permanently or as a detachable component to the existing product line using passive components. Examples include but are not limited to inlet/ discharge stack caps, hoods, filters, discharge nozzles, evasés, transitions, guide vanes, fans in a box with varying wall spacings etc. These modifications could either enhance or diminish the original fan performance.

The effect of the modification is determined by comparing tested fan curves with and without the modification. The difference between these fan curves, or rating factor, is normally quantified as a percentage of the inlet or

discharge velocity pressure of the component used to modify the base fan's performance. When multiple sizes are tested, this rating factor is compared with (or curve fit to) the model size or other pertinent dimensions.

Performance data can be determined with any of these methods and submitted to AMCA International as part of the Certified Ratings Program.

8.7.1 ATDM validation

To validate an ATDM, a description of the method used must be provided to AMCA International per the licensee's confidentiality agreement along with proposed testing and rating data developed from the ATDM. Precertification tests will be required as follows: Instead of a single comparison between the AMCA International testing laboratory (or independent laboratory) test data and the licensee's submitted test data, one test for each unique modification, on a non-tested size, --different from those used for rating factor development— shall be conducted at the AMCA International testing laboratory (or independent laboratory). This precertification test result/results shall be compared with the licensee's ATDM data to determine overall pass/ fail result.

For each product line, AMCA International shall choose a configuration of parameters not previously tested by the licensee. The fans will be tested and compared with the submitted ATDM data. The precertification test tolerances shall be applied to each precertification test. If the tested performance is within the tolerances as described in Section 10, the ATDM is accepted and the ATDM results shall be deemed acceptable.

The predicted efficiency for each model calculated by applying the ATDM may not be more than five percent greater than the fan efficiency determined from the corresponding test of the model. The predicted airflow and pressure for each model calculated by applying the ATDM may not be more than the tolerance for airflow and pressure in Section 10

8.7.1.1 Precertification test failures

Prior to the precertification tests, the licensee shall submit to AMCA International all ATDM data to be used for catalog certification. If any precertification test fails, the licensee will be informed and given the opportunity to inspect the fan for damage or defects. If any damage or defects are found, the licensee shall repair or correct the product and the test will be repeated. If no shipping damage occurred, the licensee shall modify the ATDM and a new precertification fan(s) shall be selected and tested to validate the modified ATDM. If the modification of the ATDM affects models other than the failed model, the licensee shall submit the revised catalog. If the fan passes the retest(s), then the ATDM is accepted. If the comparison fails, the ATDM is rejected and the licensee can choose to develop a new ATDM; the process starts over with a new ratings data submittal and precertification test units.

8.7.1.2 Catalog checks for fans using ATDM

The catalog checks performed for a product line using an ATDM will employ either base tests, if applicable, or the ATDM data submitted prior to the final precertification tests.

8.7.1.3 Application of check test tolerances

The check test tolerances as described in Section 10 shall be applied to each precertification test. If the tested performance is within the tolerances as described in Section 10, the ATDM is accepted and the ATDM results shall be used for the catalog performance check.

9. Ratings Method Details

A summary of available ratings methods is found in Annex F.

9.1 Rating method A/B/D: Centrifugal, mixed-flow, axial, propeller fans, power roof ventilators (PRVs), energy recovery ventilator (ERVs) and axial impellers (constant speed rating method)

This method applies to the following:

- Belt drive units with integral shaft and bearings rated at a constant speed.
- Direct drive units with low-slip motors rated at a constant speed.

9.1.1 Calculated performance

The test fan performance shall be used as the basis for calculating the performance of the test fan to other speeds, a larger fan or a series of larger fans using the fan laws or a validated APDM. See Annex D for more information. Calculating to other speeds for direct drive fans requires measuring fan input power.

9.1.2 Published data

The performance ratings of each model number shall include the following:

- Volumetric airflow rate
- Fan static pressure and/or fan total pressure
- Choice of (one or more):
 - Fan input power;
 - Maximum fan input power over the range cataloged;
 - Fan input power at the stated duty;
 - Maximum motor (or motor control) input power, nominal efficiency and/or motor model number, voltage and frequency over the range cataloged
 - Motor (or motor control) input power, nominal efficiency and/or motor model number, voltage and frequency at the stated duty.
- Impeller speed
- Inlet air density (if other than standard air)
- If publishing axial impeller ratings, see Figure A.38 and include:
 - D Impeller diameter
 - CL Cylinder length
 - Tip Tip clearance
 - G Geometry of inlet shape
 - T Position of the impeller
 - DD Driver distance

If the model also is certified for FEI or FEG, the performance ratings shall include the corresponding certified values.

Note: The “maximum fan input power over the range cataloged” is the peak input power value between the values at the greatest airflow and lowest airflow in all approved catalogs.

The following statements shall be shown immediately adjacent to the ratings tables, graphs and/or charts and may be identified by a footnote when appropriate:

“Power rating does not include transmission losses.”

Or:

“Power rating includes transmission losses.”

Note: “Transmission losses,” as used in these statements, may refer to belt drive losses, motor losses, control losses or losses caused by the addition of appurtenances, such as shaft seals, etc. Bearing losses and coupling losses are included in the power rating.

One of the following statements appropriate for the product being rated shall be shown immediately adjacent to the ratings tables, graphs and/or charts:

“Performance ratings do not include the effects of appurtenances.”

Or:

“Performance ratings include the effects of [list appurtenances here].”

In addition, for axial impellers, the following statement shall be shown immediately adjacent to the ratings tables, graphs and/or charts:

“Operation of the axial impeller in a configuration different from the published test configuration will affect performance.”

See Annex D for additional ratings information.

9.2 Rating method C/E: centrifugal, mixed-flow, axial, propeller fans, PRVs, ERVs, axial impellers and single room air handlers (as-run speed rating method)

This method applies to the following:

- Belt drive units with integral shaft and bearings featuring low slip motors rated at an as-run speed.
- Direct drive units with low slip motors rated at an as-run speed.

The actual speed cannot differ from the nominal speed by more than 3%. Power transmission losses are included in the fan power rating.

Note: “Nominal speed” is a speed midway between the highest speed of any cataloged rating point and the lowest speed of any cataloged rating point rounded to the nearest 5 rpm.

9.2.1 Calculated performance

The test fan performance shall be used as the basis for calculating the performance of the test fan to other as-run speeds, the performance of a larger fan size or a series of larger fan sizes using the fan laws. See Annex D for more information. The speed used for the calculated performance shall be based on the ratio of the test fan speed at each test point to the test fan nominal speed times the nominal speed of the calculated fan.

Calculating to other speeds for direct drive fans requires measuring fan input power.

9.2.2 Published data

The performance ratings of each model number shall include:

- Volumetric airflow rate
- Fan static pressure and/or fan total pressure
- Choice of (one or more):
 - Maximum fan input power over the range cataloged;
 - Fan input power at the stated duty;
 - Maximum motor (or motor control) input power, nominal efficiency and/or motor model number, voltage and frequency over the range cataloged
 - Motor (or motor control) input power, nominal efficiency and/or motor model number, voltage and frequency at the stated duty.
- Actual impeller speed at each point of rating or at the nominal speed
- Inlet air density (if other than standard air)
- If publishing axial impeller ratings, see Figure A.38 and include:
 - D Impeller diameter
 - CL Cylinder length
 - Tip Tip clearance

- G Geometry of inlet shape
- T Position of the impeller
- DD Driver distance

If the model is also certified for FEI or FEG, then the performance ratings shall include the corresponding certified values.

Note: The “maximum fan input power over the range cataloged” is the largest recorded input power value between the values at the greatest airflow and lowest airflow in all approved catalogs.

When a nominal speed is cataloged, the following statement shall be shown immediately adjacent to the ratings tables, graphs and/or charts:

“Speed shown is nominal. Performance is based on actual speed of test.”

One of the following statements appropriate for the product being rated shall be shown immediately adjacent to the ratings tables, graphs and/or charts:

“Performance ratings do not include the effects of appurtenances.”

Or:

“Performance ratings include the effects of [list appurtenances here].”

For belt driven fans, the following statement shall be shown immediately adjacent to the ratings tables, graphs and/or charts and may be identified by a footnote when appropriate:

“Power rating includes transmission losses.”

Additionally, for axial impellers, the following statement shall be shown immediately adjacent to the ratings tables, graphs and/or charts:

“Operation of the axial impeller in a configuration different from the published test configuration will affect performance.”

9.3 Rating method F: Centrifugal, mixed-flow, axial, propeller fans, PRVs, ERVs, axial impellers and single room air handlers

This method applies to direct driven units with high slip motors rated at an as-run speed where the actual speed varies over the cataloged range of fan performance by more than 3%.

9.3.1 Calculated performance

No calculations to other sizes are permitted. For calculations to other speeds, Annex I shall be utilized.

In the case of multiple speed high slip motors (shaded pole, permanent split capacitor, universal, etc.), the performance rating shall be as-run for each speed based on tests at each speed.

9.3.2 Published data

The performance ratings of each model number shall include:

- Airflow rate
- Fan static pressure and/or fan total pressure
- Maximum motor (or motor control) input power, nominal efficiency and/or motor model number, voltage and frequency over the range cataloged, or motor input power, voltage and frequency at the stated duty (optional if less than 500 W)
- Actual impeller speed at each point of rating or a nominal speed
- Inlet air density (if other than standard air)
- If publishing axial impeller ratings, see Figure A.38 and include:
 - D Impeller diameter
 - CL Cylinder length
 - Tip Tip clearance
 - G Geometry of inlet shape
 - T Position of the impeller
 - DD Driver distance

If the model is also certified for FEI or FEG, then the performance ratings shall include the corresponding certified values.

The nominal speed shall be approximately in the middle of the actual speed range over the performance range cataloged.

When a nominal speed is cataloged, the following statement shall be shown immediately adjacent to the ratings tables, graphs and/or charts:

“Speed shown [rpm] is nominal. Performance is based on actual speed of test.”

One of the following statements appropriate for the product being rated shall be shown immediately adjacent to the ratings tables, graphs and/or charts:

“Performance ratings do not include the effects of appurtenances.”

Or:

“Performance ratings include the effects of [list appurtenances].”

Additionally, for axial impellers, the following statement shall be shown immediately adjacent to the ratings tables, graphs and/or charts:

“Operation of the axial impeller in a configuration different from the published test configuration will affect performance.”

9.4 Rating method G: Air curtains

Air curtains may be direct or belt driven. Power transmission losses, if any, are included in the power rating.

9.4.1 Calculated performance

9.4.1.1 Air performance

The test air curtain air performance ratings may be used as the basis for calculating the air curtain performance at other speeds using the fan laws. See Annex D for more information.

If motor input power is measured during the air performance test, fan input power may be calculated using the motor calibration curve for the motor used during the test. Fan input power at other speeds then may be calculated using the fan laws. Motor input power then may be calculated using a motor calibration curve for the motor typically supplied with the air curtain at the rated speed.

If fan input power is measured during the air performance test, fan input power may be used to calculate fan input power at other speeds using the fan laws. A motor calibration curve for the motor typically supplied with the air curtain then shall be used to determine the motor input power at the rated speed.

9.4.1.2 Multiple identical modules

Where the test of a single module is used to rate a unit composed of a group of identical modules, the airflow rate shall be the airflow rate of the single module times the number of identical modules. The power rating for a combination of identical modules shall be the input power of the single module times the number of identical modules.

Where the airflow rate of a single module is derived from a test of a unit comprised of multiple identical modules, the airflow rate of each single module shall be the total airflow rate of the unit divided by the number of modules. The power rating of a single module shall be the total motor input power of the unit divided by the number of modules.

9.4.1.3 Dissimilar multiple modules

Where necessary, airflow rate and module power shall be determined from a comparative test of units made up of dissimilar modules.

Example:

Air Curtain Construction	
Unit No. 1	Unit No. 2
3 A modules + 1 B module	2 A modules + 1 B module

The airflow rate of Module A is the airflow rate of Unit No.1 less the airflow rate of Unit No. 2. The motor input power rate of Module A is the input power of Unit No.1 less the input power of Unit No. 2

Subsequently, the airflow rate of Module B is the airflow rate of Unit No.1 less three times the airflow rate of Module A. The motor input power of Module B is the motor input power of Unit No. 1 less three times the input power of Module A.

9.4.1.4 Average outlet velocity

The average outlet velocity for a single module or a combination of modules shall be the airflow rate divided by the face area of the discharge nozzle.

9.4.1.5 Outlet velocity uniformity

In an air curtain unit comprised of multiple modules, the unit's outlet velocity uniformity shall be equal to that of the module with the lowest uniformity in the unit.

9.4.1.6 Velocity projection

The velocity projection for a combination of identical modules is the same as the velocity projection found from the test of one of the single modules.

The velocity projection test of a unit with multiple identical modules shall not be used to determine the velocity projection of a single module.

The velocity projection of units comprised of multiple dissimilar modules shall not be derived from tests of single modules.

9.4.2 Published data

The performance ratings of each model number shall include the following:

- Volumetric airflow rate
- Average outlet velocity
- Motor input power, nominal efficiency and/or motor model number, voltage and frequency
- Outlet velocity uniformity
- Inlet air density (if other than standard air)

Published for only one size, which shall be stated, at standard inlet air density:

- Velocity projection

The following statement shall be shown immediately adjacent to the ratings tables, graphs and/or charts:

“The AMCA Certified Ratings Program seal applies to airflow rate, average outlet velocity, outlet velocity uniformity, velocity projection and power rating at free delivery only.”

The manufacturer shall describe with the following statement the conditions under which the air curtain unit was tested and list the presence or absence of optional appurtenances available for arrangements that are cataloged but not included in the certified ratings. For example:

“Rated data shown are only for base (unheated) units, as shown.”

The manufacturer may provide data that lists the effects on performance in the form of correction factors due to the presence of optional appurtenances available for arrangements that are cataloged but are not included in the AMCA Certified Ratings. It shall be described by the following statement, explaining that the performance obtained using these correction factors shall not be considered a certified rating but only an approximation.

“Performance data obtained from the correction factors shown herein are only an approximation and shall not be considered as part of the AMCA Certified Ratings.”

9.5 Rating method H: Jet fans

9.5.1 Calculated performance

Direct drive jet fans are rated at an as-run speed. The test fan performance may be used as the basis for calculating the performance of other fans sizes or speeds as permitted in accordance with ANSI/AMCA Standard 250 and ISO 13350.

9.5.2 Published data

The catalog data published under the AMCA Certified Ratings Program shall be determined in accordance with ANSI/AMCA Standard 250 and ISO 13350 and conform to the following requirements:

The performance rating for each model shall include:

- Nominal impeller speed
- Thrust
- Inlet air density (if other than standard air)

Choice of:

- Fan electrical input power or
- Fan impeller power

If volumetric airflow rate is published, it shall be calculated from thrust and gross outlet area in accordance with the following equation:

$$Q = \sqrt{\frac{A_2 T_c}{\rho_{std}}} \quad (\text{SI}) \quad \text{Eq. 9.1}$$

$$Q = 340.3 \sqrt{\frac{A_2 T_c}{\rho_{std}}} \quad (\text{IP}) \quad \text{Eq. 9.2}$$

If the model also is certified for FEI, the performance rating shall include the corresponding certified values.

The following statements shall be shown immediately adjacent to the ratings tables, graphs and/or charts:

“The AMCA Certified Ratings Program seal applies to thrust at free delivery only. Speed rpm] shown is nominal. Performance is based on actual speed of test.”

And:

“Performance ratings [include or do not include] the effects of appurtenances on the [inlet, outlet or inlet and outlet].”

When the effect of an appurtenance is included in the fan performance rating, the following statement shall be shown adjacent to the rating:

“Performance ratings include the effect of [list appurtenances (including silencers) here].”

9.6 Rating method I: Agricultural ventilation fans

This method applies to the following:

- Agricultural ventilation fans with integral shaft and bearings supplied with a low slip motor that is rated at as-run speeds. Power transmission losses are included in the fan power rating.
- Direct drive agricultural ventilation fans supplied with low slip motors that are rated at as-run speeds.

9.6.1 Calculated performance

No calculations to other speeds or sizes are permitted.

9.6.2 Published data

Each fan appurtenance assembly shall have a distinct model number different from one without appurtenances or with a different group of appurtenances.

The performance rating of each model number shall include:

- Volumetric airflow rate at 10 Pa (0.05 in. wg) and 30 Pa (0.125 in. wg) static pressure (Ratings at other static pressures are optional.)
- Actual impeller speed at each point of rating or a nominal speed
- Volumetric airflow rate/electrical input power, motor nameplate voltage and frequency
- Motor (or motor control) input power, nominal efficiency and/or motor model number
- Inlet air density (if other than standard air)

If the model is also certified for FEI, the performance rating shall include the corresponding certified values.

The nominal speed shall be approximately in the middle of the actual speed range over the performance range cataloged. The actual speed shall not differ from the nominal speed by more than 3%.

The following statement shall be shown adjacent to the rating:
“Speed [rpm] shown is nominal. Performance is based on actual speed of test.”

When the effect of appurtenances is included in the fan performance rating, the following statement shall be shown adjacent to the rating:
“Performance ratings include the effect of [list appurtenances here].”

9.7 Rating method J: PPVs

9.7.1 Calculated performance

Direct drive PPVs are rated at an as-run speed. No calculations to other speeds or sizes are permitted.

9.7.2 Published data

The catalog data published under the AMCA Certified Ratings Program shall be determined in accordance with ANSI/AMCA Standard 240 and conform to the following requirements: Each PPV appurtenance assembly shall have a distinct model number different from PPVs without appurtenances or with a different group of appurtenances.

The performance rating of each model number shall include:

- Volumetric airflow rate
- Impeller speed
- Setback distance
- Tilt angle
- Manufacturer and model number for all motors/engines listed for use on the PPV

When the effect of appurtenances is included in the PPV performance rating, the following statement shall be shown adjacent to the rating:

“Performance ratings include the effect of [list appurtenances here].”

9.8 Rating method K: Circulating fans

9.8.1 Calculated performance

Direct driven circulating fans are rated at an as-run speed. No calculations to other speeds or sizes are permitted.

9.8.2 Published ratings

The catalog data published under the AMCA Certified Ratings Program shall be determined in accordance with ANSI/AMCA Standard 230 and conform to the following requirements:

Each fan appurtenance assembly shall have a model number different from those without appurtenances or with a different group of appurtenances.

The performance rating shall include the following items at each prescribed operating point:

- Volumetric airflow rate
- Fan system input power, phase, voltage and frequency
- Efficacy (volumetric airflow rate/electrical input power)
- Nominal impeller speed
- Direction of operation

If the model also is certified for FEI, the performance rating shall include the corresponding certified values.

Catalogs containing ratings of products certified for aerodynamic performance shall include the following statement:

“The AMCA Certified Ratings Program seal applies at free delivery only.”

The following statement shall be shown adjacent to the rating:

“Speed [rpm] shown is nominal. Performance is based on actual speed of test.”

When the effect of an appurtenance is included in the fan performance rating, the following statement shall be shown adjacent to the rating:

“Performance ratings include the effect of [list appurtenances here].”

9.9 Rating method L: Induced flow fans

Induced flow fans are housed fans with centrifugal, mixed flow or axial impellers used in a free discharge configuration that have an outlet airflow greater than their inlet airflow. They are used extensively in laboratory exhaust systems.

This rating method applies to induced flow fans with integral shaft and bearings rated at a constant speed. Power transmission losses are not included in the fan power rating (multi-speed tables, single rating tables, curves or electronic data).

9.9.1 Calculated performance

The test fan performance may be used as the basis for calculating the test performance to other speeds or to a larger fan or series of larger fans using the fan laws. See Annex D for more information.

9.9.2 Published data

The catalog data published under the AMCA Certified Ratings Program shall be determined in accordance with ANSI/AMCA Standard 260. The test setup described in Section 7.1 of ANSI/AMCA Standard 260 shall be used to determine all performance ratings listed below with the exception of “outlet airflow rate,” which uses the setup described in Section 7.2 of ANSI/AMCA Standard 260. The performance rating of each model shall include:

- Inlet volumetric airflow rate
- Fan static pressure
- Fan input power
- Impeller speed
- Inlet air density (if other than standard air)
- Outlet airflow rate
- Outlet area
- Nozzle velocity (inlet airflow rate divided by nozzle discharge area)

If the model also is certified for FEI, the performance rating shall include the corresponding certified values.

For single rating performance tables, fan input power may be stated for each point of rating or as the peak fan input power in the cataloged performance range.

The following statements shall be shown immediately adjacent to the ratings tables, graphs and/or charts and may be identified by an asterisk when appropriate:

“Power rating does not include transmission losses.”

“Performance ratings do not include the effects of cross winds.”

One of the following statements appropriate for the product being rated shall be shown immediately adjacent to the ratings tables, graphs and/or charts:

“Performance ratings do not include the effects of appurtenances.”

Or:

“Performance ratings include the effects of [list appurtenances].”

9.10 Rating method M: Residential ventilating fans

This rating method applies to residential products as defined in the latest version of the U.S. Environmental Protection Agency’s ENERGY STAR Program Requirements Product Specification for Residential Ventilating Fans, Eligibility Criteria (found on the ENERGY STAR website, www.energystar.gov), which defines a residential ventilating fan as “a ceiling, wall-mounted, or remotely mounted in-line fan designed to be used in a bathroom or utility room, or a kitchen range hood, whose purpose is to move objectionable air from inside the building to the outdoors.”

This rating method uses the motor input power and not the fan shaft input power. Ratings are developed for specific operating points for each type of fan. All ratings are determined at the as-run speeds. Motors can be either high slip or low slip motors.

9.10.1 Calculated performance

No calculations to other speeds or sizes are permitted.

9.10.2 Published data

The performance rating of each model in a product line shall include:

- Airflow rate at prescribed operating points
- Static pressure at prescribed operating points
- Minimum efficacy level (cfm/W) at prescribed operating points
- Spherical sone rating at prescribed operating points (except for in-line fans)
- Actual impeller speed at each point of rating or a nominal speed

The nominal speed shall be approximately in the middle of the actual speed range over the performance range cataloged. When a nominal speed is cataloged, the following statement shall be shown immediately adjacent to the ratings tables, graphs and/or charts:

“Speed [rpm] shown is nominal. Performance is based on actual speed of test.”

One of the following statements appropriate for the product being rated shall be shown immediately adjacent to the ratings tables, graphs and/or charts:

“Performance ratings do not include the effects of appurtenances.”

Or:

“Performance ratings include the effects of [list appurtenances here].”

9.10.3 Testing

Testing shall be accomplished, at minimum, at the operating points found in Table 9.10.

9.10.4 ENERGY STAR

If the licensee desires to obtain ENERGY STAR approval for their product,

- The licensee must be an ENERGY STAR partner.
- The product must meet the performance requirements to obtain the ENERGY STAR.
- The product submittal must include a one-year warranty that will be provided to the purchaser. The product submittal must include the required installation instructions.

The intention of the licensee to apply for ENERGY STAR status must be indicated on the submitted CRP-8 form. After testing has been completed and the application filed with AMCA International, staff will submit the required information to ENERGY STAR. Once approved, the licensee will be informed.

Table 9.10 — Operating Points for Products Using Rating Method M

Product Type	Static Pressure (in. wg)	Notes
Products with an inlet or an outlet duct	0.1 and 0.25	Sound only at 0.1 in. wg
Ducted range hoods	See note	Test at working speed per HVI 916
Unducted products	0.03	
Inline fans (ducted inlet and ducted outlet)	0.2	No sound test required

If the product includes lighting, it will be shipped to an accredited and recognized ENERGY STAR certification body for the luminaire certification prior to AMCA submitting the package to ENERGY STAR for overall approval.

The significant digits and rounding requirements found in the ENERGY STAR program requirements shall be used for all ENERGY STAR certification procedures.

9.10.5 ENERGY STAR enhanced check test requirements

The ENERGY STAR program requires the enhancements in sections 9.10.5.1 through 9.10.5.3 of this document. The enhancements apply to the AMCA International check test program for products bearing the ENERGY STAR label.

9.10.5.1 Periodicity and selection of check (verification) test sample

For this procedure, a check test and verification test are the same. AMCA International is required to select models from 10% of all ENERGY STAR qualified product lines, of each type that AMCA certifies, for annual verification tests. To determine the number of tests required per year, AMCA is required to round up any fractional number. (For example, if two bath fan product lines are ENERGY STAR approved via the AMCA International certification body, one model per year from the two product lines will have to have a verification test: 10% of two is 0.2; 0.2 rounds up to one per year.)

The source for procurement of check test units in priority order are as follows:

1. Off-the-shelf (from the open market),
2. Warehouse (from a storage depot),
3. Off-the-line (from the manufacturing facility).

Note that the ENERGY STAR partner shall not choose the testing sample.

The ENERGY STAR partner is required to provide either a list of at least three locations where a unit(s) of the product(s) to be tested or a signed statement that none are available may be obtained. If there are no off-the-shelf locations to obtain the unit, the ENERGY STAR partner is required to provide access to AMCA staff to select a unit(s) from a warehouse or off-the-line.

9.10.5.2 Check test criteria

The unit selected for the check test is required to meet the same ENERGY STAR performance requirements that it originally met. A check test failure will be reported to ENERGY STAR within two business days of failure. ENERGY STAR will determine the consequences of the failure. (The procedure for ENERGY STAR products does not allow for the option to ship the check test unit to the licensee for inspection or a re-check test.)

For published data not required for ENERGY STAR approval, AMCA International's normal check test procedures apply.

9.10.5.3 Challenge tests

In addition to the challenge test procedures found in Section 12 of AMCA Publication 11, the following requirements and modifications are made for ENERGY STAR approved products:

The basis for a challenge, which must be provided, can be marketing material that claims better performance than proved by data on record with AMCA International or a product test the challenger performs on its own. The product test data is not required to be from the AMCA International testing laboratory or an AMCA accredited laboratory.

9.11 Rating method N: Large-diameter ceiling fans

9.11.1 Calculated performance

Large-diameter ceiling fans are defined in 10 CFR Part 430, Subpart B, Appendix U as ceiling fans with an impeller diameter larger than 2.13 m (7 ft) that are not belt driven. They are rated at an as-run speed. No calculations to other speeds or sizes are permitted. Each base model must be tested.

9.11.2 Published ratings

The catalog data published under the AMCA Certified Ratings Program shall be determined in accordance with ANSI/AMCA Standard 230; 10 CFR Part 430, Subpart B, Appendix U; Section 429.32 of 10 CFR Part 429; and Section 325(ff)(6) of the Energy Policy and Conservation Act (42 U.S.C. 6295(ff)(6));-and conforms to the following requirements:

Each fan appurtenance assembly shall have a distinct model number different from one without appurtenances or one with a different group of appurtenances.

Each base model will be tested at a minimum of two test points; the maximum impeller rotational speed (high speed) and 40 % speed or the nearest speed that is not less than 40 % speed. Additional test speeds are allowed.

The rating shall include:

- Impeller diameter
- Tested fan system input voltage, number of phases and frequency
- CFEI at maximum impeller rotational speed (high speed) and 40 % speed or the nearest speed that is not less than 40 % speed.

Additionally, the performance rating shall include the following items at each prescribed test point:

- Volumetric airflow rate
- Fan system input power
- Impeller rotational speed
- Direction of operation (downward or upward flow)

Airflow rate, fan system input power, and CFEI rating shall be calculated in accordance with 10 CFR Part 430: 10 CFR Part 429; and Section 325(ff)(6) of the Energy Policy and Conservation Act (42 U.S.C. 6295(ff)(6)). The ratings shall be based on a minimum of two samples for each model.

Conservative CFEI, airflow rate, and fan system input power ratings may be certified under the AMCA Certified Ratings Program.

Catalogs containing ratings of large diameter ceiling fan aerodynamic performance shall include the following statement:

“The AMCA Certified Ratings Program seal applies to airflow rate and power rating free delivery only.”

When the effect of an appurtenance is included in the fan performance rating, the following statement shall be shown adjacent to the ratings:

“Performance ratings include the effects of [list appurtenances].”

10. Check Tests

Certified products are subject to precertification and periodic check tests as defined in AMCA Publication 11. When products are check tested, the check test performance shall be within the tolerance for airflow, pressure, and power (defined below) when compared with the manufacturer’s catalog data. For precertification check tests, this comparison is made with the original rating test data.

For products cataloged using constant or as-run speed tables, the tolerance shall be applied to the catalog points only. For products cataloged using multi ratings tables or curves, the tolerance shall be applied over the performance range cataloged.

When one or more models within the product line have ratings calculated using the fan laws or other methods rather than tested, the first check test shall be conducted on a model not originally tested to validate the calculation procedures.

Fans check tested with calibrated motors shall be tested at the same voltage used for the motor calibration.

Fan check test performance shall be converted to the cataloged air density.

Fans rated at as-run speeds shall be check tested at a density within 1.12 to 1.2 kg/m³ (0.070 to 0.075 lbm/ft³).

Fans rated at a constant speed shall be tested at a speed within 5% of the cataloged speed.

Fans shall be check tested in the same configuration as originally tested.

10.1 Centrifugal, mixed-flow, axial, propeller and agricultural fans, PRVs, PPVs and ERVs

10.1.1 Test methods

Check tests will be conducted with the same inlet and outlet conditions as the original rating test.

10.1.2 Check test tolerances for fans delivered by the manufacturer

The following check test tolerances apply to all centrifugal, mixed-flow, axial propeller and agricultural ventilation fans, PRVs, PPVs and ERVs as defined in the product ratings requirements sections (Section 11 through 22 of this document).

10.1.2.1 Airflow tolerance

The low- and high-limit fan pressure curves for acceptable fan air performance is derived by applying the check test tolerance to the catalog air performance ratings or, in the case of a precertification check, to the original rating test data.

For periodic check tests, the airflow tolerance is 5%.

$$T_Q = 5\%$$

For precertification check tests where the same fan was tested at two different labs, the airflow tolerance is reduced to 3%.

$$T_Q = 3\%$$

The low limit for airflow is:

$$Q_{test} \geq Q \cdot (1 - T_Q) \quad \text{Eq. 10.1}$$

The low limit for pressure is:

$$P_{s,test} \geq P_s \cdot (1 - T_Q)^2 \quad \text{or} \quad P_{t,test} \geq P_t \cdot (1 - T_Q)^2 \quad \text{Eq. 10.2}$$

The high limit for airflow is:

$$Q_{test} \leq Q \cdot (1 + T_Q) \quad \text{Eq. 10.3}$$

The high limit for pressure is:

$$P_{s,test} \leq P_s \cdot (1 + T_Q)^2 \quad \text{or} \quad P_{t,test} \leq P_t \cdot (1 + T_Q)^2 \quad \text{Eq. 10.4}$$

Where:

T_Q is the airflow tolerance

Q is rated catalog fan airflow rate, or originally tested airflow for a precertification test

P_s is rated catalog fan static pressure, or originally tested fan static pressure for a precertification test

P_t is rated catalog fan total pressure, or originally tested fan total pressure for a precertification test

Q_{test} is the check test airflow

$P_{s,test}$ is the check test fan static pressure

$P_{t,test}$ is the check test fan total pressure

The check test performance shall not be outside the low and high tolerance limits (curve or points) over the performance range cataloged (see Figure 10.1).

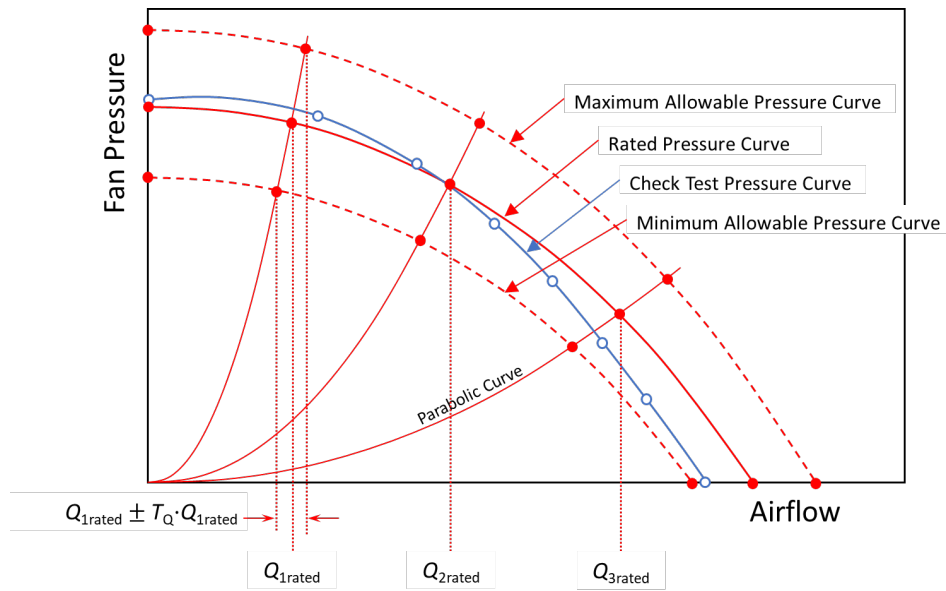

Figure 10.1 — Application of Airflow Tolerance

10.1.2.2 Power tolerance

The high limit power curve for acceptable fan performance is derived by applying the check test tolerance to the catalog air performance ratings or, in the case of a precertification check, to the original rating test data. The power required by the check test fan, when converted to the catalog airflow, shall not exceed the rated power (curve or points) by more than the power tolerance, T_H or T_W .

The converted check test power shall not be greater than the tolerance limit (curve or points) over the performance range cataloged (see Figure 10.2).

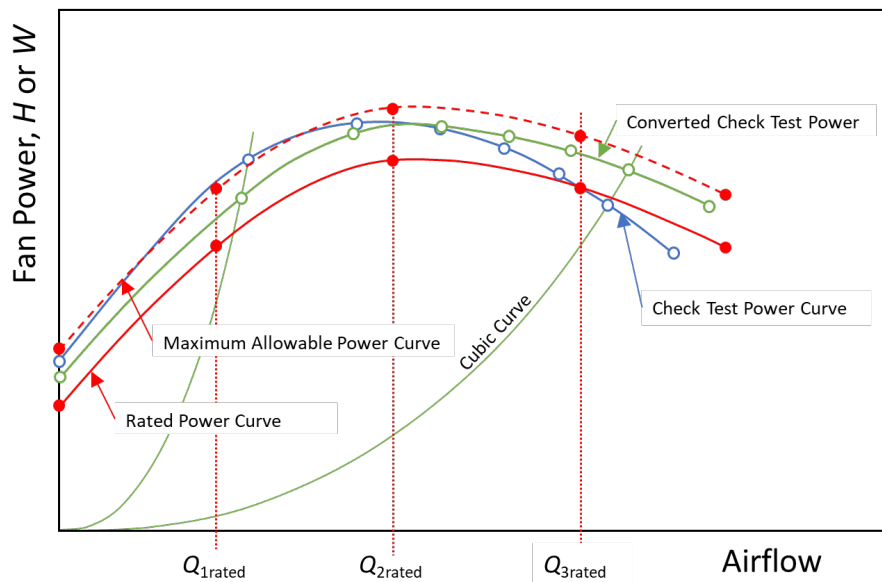

Figure 10.2 - Application of Power Tolerance

10.1.2.2.1 Fan shaft power

For fans tested shaft-to-air, the value of T_H for periodic check tests shall be 7.5% of the rated power at the rated airflow rate. For precertification check tests, the value of T_H is reduced to 5% of the rated power. The value of T_H shall in no case be less than 37 W (0.05 hp).

Periodic check tests:

$$\begin{aligned} T_H &= \text{Maximum (7.5\% rated power, 37 W)} && \text{(SI)} \\ T_H &= \text{Maximum (7.5\% rated power, 0.05 hp)} && \text{(I-P)} \end{aligned}$$

Precertification check tests:

$$\begin{aligned} T_H &= \text{Maximum (5\% rated power, 37 W)} && \text{(SI)} \\ T_H &= \text{Maximum (5\% rated power, 0.05 hp)} && \text{(I-P)} \end{aligned}$$

The converted power is:

$$H_c = H_{i,test} \cdot \left(\frac{Q}{Q_{test}} \right)^3 \quad \text{Eq. 10.5}$$

The high limit for power is:

$$H_c \leq H + T_H \quad \text{Eq. 10.6}$$

Where:

Q is the rated catalog fan airflow rate, or originally tested airflow for a precertification test

Q_{test} is the check test airflow

$H_{i,test}$ is the check test fan input power

H is the rated catalog fan input power, or the originally tested fan input power for a precertification test

T_H is the fan input power tolerance

H_c is the converted fan input power

10.1.2.2.2 Fan electrical input power

For fans tested wire-to-air, the value of T_W for periodic check tests shall be 10% of the rated power at the rated airflow rate. For precertification check tests, the value of T_W is reduced to 5% of rated power. The value of T_W shall in no case be less than 50 W.

Periodic check tests:

$$T_W = \text{Maximum (10\% rated power, 50 W)}$$

Precertification check tests:

$$T_W = \text{Maximum (5\% rated power, 50 W)}$$

The converted power is:

$$W_c = W_{test} \left(\frac{Q}{Q_{test}} \right)^3 \quad \text{Eq. 10.7}$$

The high limit for power is:

$$W_c \leq W + T_W \quad \text{Eq. 10.8}$$

Where:

Q is the rated catalog fan airflow rate, or the originally tested airflow for a precertification test

Q_{test} is the check test airflow

W_{test} is the check test electrical input power

W is the rated catalog electrical input power, or the originally tested electrical input power for a precertification test

T_W is the electrical input power tolerance

W_c is the converted electrical input power

10.1.2.3 Check test requirements for fans with certified FEG

If the check-test unit (the model subject to a check test) passes the air-performance check-test criteria, the FEG rating for that model shall be considered to have passed the check test. If the check-test performance is not within the air-performance check-test tolerance, the FEG for that model shall be determined based on the revised base test data.

If an axial flow fan is certified in multiple pitches (where the customer can change the pitch) and the check test for this product line fails, the FEG shall be determined based on the revised base test data.

10.1.2.4 Check test requirements for fans with certified FEI and CFEI

If the check test unit (the model subject to a check test) passes the air performance check test criteria, the catalog ratings for that model shall be used to verify the FEI or CFEI calculation. If the check test performance is not within the air performance check test tolerance, the FEI or CFEI for that model also is considered failed, and an updated FEI or CFEI value shall be determined based on the revised base test data.

In the context of a check test for a fan with certified FEI, the air performance will include the airflow, pressure and power ratings. There are several ways in which power ratings can be developed and several ways they can be published. The comparison of tested power ratings vs. published power ratings shall be made according to Table 10.1. In the context of a check test for a fan with certified CFEI, the air performance will include the airflow and power ratings, other commonly published data such as air speed at occupant level is not included.

Table 10.1 – FEI Power Ratings Check Tests

Base Test Configuration	Calculation Method	Published Data	Check Test	Additional Check
Wire-to-air	Annex I	FEI, W_c	W_c	FEI calculations
Shaft input power	AMCA 207	FEI, W_c and/or H_i	H_i	FEI and W_c calculations
Shaft input power	Annex H	FEI, W_c and/or H_i	H_i	FEI and W_c calculations, periodic motor test, see Section 10.6

Notes: W_c is electrical input power to the motor control
 H_i is fan input power

10.1.3 Tolerances for fans obtained in the marketplace

If the device's air performance is within Table 10.2 modified tolerances, no further action must be taken. If outside Table 10.2 tolerances, then the procedures of AMCA Publication 11 shall be followed.

For single rating tables, P is based on the maximum cataloged power at the tested speed.

Table 10.2 — Tolerance Modifiers for Fans Obtained from the Marketplace

Category	Cataloged Power, P (kW)		Multiply Airflow Tolerance (T_a) By	Multiply Power Tolerance (T_w) By
	Min	Max		
1		0.74	3	*
2	0.75	7.4	2	1.5
3	7.5		1.5	1.2

* Power less than 0.75 kW shall not be more than 50 W above the cataloged figure

10.2 Air curtains

10.2.1 Check test tolerances for air curtains delivered by the manufacturer

The following check test tolerances apply to all air curtains delivered by the manufacturer.

10.2.1.1 Airflow rate and power tolerances

Air curtain units or modules when operated at standard inlet air density shall perform to deliver no less than 95% of rated airflow at no more than 115% of the published input power rating. The measured check test results shall be converted to standard air density.

10.2.1.2 Outlet velocity uniformity tolerance

Air curtain units shall perform so the outlet velocity uniformity is not less than 85% of the published outlet velocity uniformity.

10.2.1.3 Velocity projection tolerance

Air curtain units shall perform so the average core velocity measured is not less than 85% of the average core velocity at each distance published.

10.2.2 Check test tolerances for air curtains obtained in the marketplace

The following check test tolerances apply to all air curtains obtained in the marketplace:

10.2.2.1 Airflow rate and power tolerances

Air curtain units or modules when operated at standard inlet air density shall deliver no less than 90% of rated airflow at no more than 130% of the published input power rating. The measured check test results shall be converted to standard air density.

10.2.2.2 Outlet velocity uniformity tolerance

Air curtain units shall perform so the outlet velocity uniformity is not less than 70% of the published outlet velocity uniformity.

10.2.2.3 Velocity projection tolerance

Air curtain units shall perform so the average core velocity measured is not less than 70% of the average core velocity at each distance published.

10.3 Jet fans

10.3.1 Check test tolerances for jet fans delivered by the manufacturer

The following check test tolerances apply to all jet fans delivered by the manufacturer:

10.3.1.1 Thrust and power tolerances

Jet fans shall deliver no less than 95% of their rated thrust at no more than 102% of their rated power.

10.3.2 Check test tolerances for jet fans obtained in the marketplace

The following check test tolerances apply to all jet fans obtained in the marketplace:

10.3.2.1 Thrust and power tolerances

Jet fans shall deliver no less than 94% of their rated thrust at no more than 105% of their rated power.

10.4 Circulating fans

10.4.1 Check test tolerances for circulating fans delivered by the manufacturer

The following check test tolerances apply to all fans at each prescribed operating point that are delivered by the manufacturer:

10.4.1.1 Airflow rate and power tolerances

Circulating fans shall deliver no less than 95% of their rated airflow at no more than 110% of the input power rating.

10.4.2 Check test tolerances for circulating fans obtained on the open market

The following check test tolerances apply to all circulating fans obtained on the open market:

10.4.2.1 Airflow rate and power tolerances

Circulating fans shall deliver no less than 90% of their rated airflow at no more than 120% of the input power rating.

10.5 Induced flow fans

Inlet airflow rate, fan static pressure, and fan input power check test tolerances as described in Section 10.1 shall be applicable to induced flow fans with the following additions:

The outlet airflow check test tolerance is based on the inlet airflow and the percent tolerance is twice the tolerance described in Section 10.1.

The induced-flow fan outlet area (wind band outlet area) shall measure within $\pm 2\%$ of the published value.

10.6 PDS

If motors and/or PDS are tested in an AMCA accredited laboratory in accordance with the test standards listed in Annex H, a sample PDS shall be chosen for a check test once every three years. The PDS losses shall not be greater than 120% of the published value. For example, if the published PDS efficiency is 90%, the losses would be 10%. The measured efficiency then shall be greater than 88% ($100\% - 10\% \times 1.2$). If the check test results for the PDS are not within this tolerance, PDS test will be considered as a failed check test. The performance of the PDS shall be determined based on the revised PDS check test data and another check test shall be conducted within one year.

If the PDS check test fails, the catalog ratings of the model that uses the PDS, shall be reviewed using the revised PDS test data. If the catalog data is not within one-quarter of the equivalent check test tolerance using the revised PDS test data, the catalog data shall be revised.

11. Product Rating Requirements for Centrifugal and Mixed Flow Fans

11.1 Product configuration

11.1.1 Basic conditions

All determinations for centrifugal fan performance ratings are to be based on an unobstructed inlet and outlet except for the structural features of the fan involved or on appurtenances in place that are shown or described as being in place as an integral part of the fan in the published catalog. Where appurtenances are included as part of the fan configuration, they shall be in place during the test and typical of the appurtenances provided to the public.

11.1.2 Non-similar products

When various width centrifugal impellers or various diameter impellers are used in the same scroll housings, the fans are not considered geometrically similar. The performance of various width impellers in the same housing, various width impellers in a housing that varies in width only and various diameters of impellers in the same housing may be derived by interpolation between tested fans, provided that a clear relationship of the variable to the fan performance can be demonstrated. Calculation to larger sizes may be based on interpolated performance, provided that requirements of Annex A for similarity are met (See Annex Section D.2 for more information on similarity). It is incumbent on the manufacturer to establish the validity of the relationship and ensure that the interpolation method used is consistent and results in ratings within the AMCA Certified Ratings Program tolerance.

11.1.3 Airstream restrictions

If the fan is designed with motors, sheaves, bearings and shafts in the airstream, they shall be in place during the test. Sizes of these components shall be as typically provided to the public.

11.1.4 Arrangements and classes

Where a centrifugal fan is manufactured in various arrangements or classes, any arrangement or class may be tested and used as the basis of performance ratings, provided that geometric similarity exists and all classes are identical in design except for heavier material gauges.

The effect of internal restrictions, such as tie rods, reinforcing rings and bearing supports in the impeller inlet, may be accounted for by using ratings factors.

Rating factors may be published to modify the performance rating of an unrestricted fan to account for the performance changes caused by restrictions in the airstream. The rating factor may be based on the manufacturer's experience and need not be the subject of separate validation tests. It is incumbent on the manufacturer to ensure that performance ratings obtained by using ratings factors result in performance ratings that are within the AMCA Certified Ratings Program tolerances.

11.2 Test conditions

11.2.1 Test methods

The air performance ratings of a fan or a series of similar fans shall be developed from tests conducted in accordance with ANSI/AMCA Standard 210, ISO 5801 or other testing standards recognized in AMCA Publication 111. The test method shall be consistent with the test setup of the reference test standard.

11.2.2 Electrical power requirements

When electrical input power is cataloged, the tested motor shall be operated at the catalog voltage and frequency or, where a voltage range is stated, it shall be the mean voltage. Additionally, the temperature of the motor winding must be stable for each tested operating point.

11.3 Test data submittal requirements

11.3.1 Test data

The test data submitted to AMCA International shall include the raw test data as defined in ANSI/AMCA Standard 210, ISO 5801 or other standards recognized in AMCA Publication 111. The test standard used shall be identified by the issuing organization, number and year of issue.

The test data shall be calculated to standard inlet air density and may be calculated to a constant speed.

11.3.2 Test range

The test shall cover the performance range to be cataloged, except that performance may be extrapolated to zero fan static pressure, provided that the airflow so obtained does not exceed the highest test airflow by more than 10%. The portion of the curve obtained by extrapolation shall be a smooth continuation of the curve. In the case of the total or fan static pressure curve, the extrapolation to zero must have the same or smaller radius of curvature as the adjacent portion of the curve, but in no case can it be concave upward.

Extrapolation of the power curve shall be via a straight-line tangent to the adjacent portion of the curve.

12. Product Rating Requirements for Axial Fans

12.1 Product configuration

12.1.1 Basic conditions

All determinations for axial fan performance ratings are to be based on an unobstructed inlet and outlet except for the structural features of the fan involved or appurtenances in place that are shown or described as being in place as an integral part of the fan in the published catalog. Where appurtenances are included as part of the fan configuration, they shall be in place during the test and typical of the appurtenances provided to the public.

12.1.2 Interpolation and solidity

12.1.2.1 Interpolation of data

The performance of a series of axial fans that are identical except for one variable (such as blade pitch angle, number of blades, hub to tip diameter ratio, etc.) may be derived by interpolation between tested fans, provided that a clear relationship of the variable to the fan performance can be demonstrated. Calculation to larger sizes may be based on interpolated performance, provided that the requirements of proportionality are met. It is incumbent upon the manufacturer to establish the validity of the relationship and ensure that the interpolation method used is consistent and results in ratings within the AMCA Certified Ratings Program tolerances.

12.1.2.2 Solidity and other identities

The performance of an axial fan product line that is geometrically similar except for the fan blades can be derived using solidity, changing blade numbers and chords while maintaining blade profile shape (same airfoil sections) and blade solidity (ratio of total of blade chords divided by swept circumference). In such cases, it may be possible to derive the aerodynamic performance, but not the sound, of the fan range or parts thereof by testing a minimum of three sizes of units and demonstrating that a clear relationship exists between the fan performance and the variables.

See the additional requirements for the precertification check test in Section 12.4.

12.1.2.3 Establishing relationship

The procedure for establishing the relationship between the fan performance and the variables is the manufacturer's responsibility, but it must be based on data derived from tests conducted to the same standard and test methods as those used for the remainder of the range.

12.1.3 Airstream restrictions

If the fan is designed with motors, sheaves, bearings and shafts in the airstream, they shall be in place during the test. Sizes of these components shall be as typically provided to the public. A dummy or simulated motor may be used when the fan power is measured using a dynamometer.

12.2 Test conditions

12.2.1 Test methods

The air performance ratings of a fan or series of similar fans shall be developed from tests conducted in accordance with ANSI/AMCA Standard 210, ISO 5801 or other testing standards recognized in AMCA Publication 111. The test method shall be consistent with the test setup of the reference test standard.

12.2.2 Electrical power requirements

When electrical input power is cataloged, the tested motor shall be operated at the catalog voltage and frequency, or, where a voltage range is stated, it shall be the mean voltage. Additionally, the temperature of the motor winding shall be stable for each tested operating point.

12.3 Test data submittal requirements

12.3.1 Test data

The test data submitted to AMCA International shall include the raw test data as defined in ANSI/AMCA Standard 210, ISO 5801 or other standards recognized in AMCA Publication 111. The test standard used shall be identified by issuing organization, number and year of issue.

The test data shall be calculated to standard inlet air density and may be calculated to a constant speed.

12.3.2 Test range

The test shall cover the performance range to be cataloged, except that performance may be extrapolated to zero fan static pressure, provided that the airflow so obtained does not exceed the highest test airflow by more than 10%. The portion of the curve obtained by extrapolation shall be a smooth continuation of the curve. In the case of the total or fan static pressure curve, the extrapolation to zero must have the same or smaller radius of curvature as the adjacent portion of the curve, but in no case can it be concave upward.

Extrapolation of the power curve shall be via a straight-line tangent to the adjacent portion of the curve.

12.4 Precertification check tests

When Section 12.1.2.2 is used to rate a product line, the precertification check test shall be conducted on a size and/or configuration not originally tested to validate the ratings procedures. In all other cases, the precertification check test shall be conducted on a size and configuration tested to establish the product's ratings.

13. Product Ratings Requirements for Propeller Fans

13.1 Product configuration

13.1.1 Basic conditions

All determinations for propeller fan performance ratings are to be based on an unobstructed inlet and outlet except for the structural features of the fan involved or appurtenances in place that are shown or described as being in place as an integral part of the fan in the published catalog. Where appurtenances are included as part of the fan configuration, they shall be in place during the test and typical of the appurtenances provided to the public.

13.1.2 Interpolation of data

The performance of a series of propeller fans that are identical except for one variable (e.g., blade pitch angle, number of blades) may be derived by interpolation among tested fans, provided that a clear relationship of the variable to the fan performance can be demonstrated. Calculation to larger sizes may be based on interpolated performance, provided that the requirements of proportionality are met. It is incumbent upon the manufacturer to

establish the validity of the relationship and ensure that the interpolation method used is consistent and results in ratings within the check-test tolerances.

13.1.3 Airstream restrictions

If the fan is designed with motors, sheaves, bearings and shafts in the airstream, they shall be in place during the test. Sizes of these components shall be as typically provided to the public. A dummy or simulated motor may be used when the fan power is measured using a dynamometer.

13.2 Test conditions

13.2.1 Test methods

The air performance ratings of a fan or a series of similar fans shall be developed from tests conducted in accordance with ANSI/AMCA Standard 210, ISO 5801 or other testing standards recognized in AMCA Publication 111. The test method shall be consistent with the test setup of the reference test standard.

13.2.2 Electrical power requirements

When electrical input power is cataloged, the tested motor shall be operated at the catalog voltage and frequency, or, where a voltage range is stated, the voltage range shall be the mean voltage. Additionally, the temperature of the motor winding has to be stable for each tested operating point.

13.3 Test data submittal requirements

13.3.1 Test data

The test data submitted to AMCA International shall include the raw test data as defined in ANSI/AMCA Standard 210, ISO 5801 or other standards recognized in AMCA Publication 111. The test standard used shall be identified by issuing organization, number and year of issue.

The test data shall be calculated to standard inlet air density and may be calculated to a constant speed.

13.3.2 Test range

The test shall cover the performance range to be cataloged, except that performance may be extrapolated to zero fan static pressure, provided that the airflow so obtained does not exceed the highest test airflow by more than 10%. The portion of the curve obtained by extrapolation shall be a smooth continuation of the curve. In the case of the total or fan static pressure curve, the extrapolation to zero must have the same or smaller radius of curvature as the adjacent portion of the curve, but in no case can it be concave upward.

Extrapolation of the power curve shall be via a straight-line tangent to the adjacent portion of the curve.

14. Product Ratings Requirements for PRVs

14.1 Product configurations

14.1.1 Basic conditions

All determinations for PRV performance ratings are to be based on an unobstructed inlet and outlet, except for the structural features of the fan involved or appurtenances in place that are shown or described as being in place as an integral part of the PRV in the published catalog. Where appurtenances are included as part of the fan configuration, they shall be in place during the test and typical of the appurtenances provided to the public.

14.1.2 Interpolation of data

The performance of a series of PRVs that are identical except for one variable (e.g., blade pitch angle, number of blades) may be derived by interpolation among tested PRVs, provided that a clear relationship of the variable to the PRV performance can be demonstrated. Calculation to larger sizes may be based on interpolated performance provided that the requirements of proportionality are met. It is incumbent upon the manufacturer to establish the validity of the relationship and ensure that the interpolation method used is consistent and results in ratings within the check-test tolerances.

14.1.3 Airstream restrictions

If the PRV is designed with motors, sheaves, bearings and shafts in the airstream, they shall be in place during the test. Sizes of these components shall be as typically provided to the public. A dummy or simulated motor may be used when the fan power is measured using a dynamometer.

14.1.4 Roof curb installations

PRVs usually installed on roof curbs shall be tested upon a simulated curb conforming to the minimum recommended curb height and inside dimensions shown in the catalog. In the absence of recommendations, the curb height shall not exceed 150 mm (6 in.) and the inside dimensions shall be at least 100 mm (4 in.) less than the inside dimensions of the curb cap for units with impeller diameters up to and including 750 mm (30 in.) and at least 200 mm (8 in.) less than the curb cap for units with impeller diameters greater than 750 mm (30 in.).

14.1.5 Simulated roofs

All PRVs with hoods that direct the air downward toward the roof shall be tested with a simulated roof that is flat and normal to the axis of the PRV. The simulated roof shall extend beyond the maximum overhang of the hood a distance of one-half the impeller diameter in all directions. However, one side of the hood may be blocked by the floor or a wall of the test setup.

14.2 Test conditions

14.2.1 Test methods

The air performance ratings of a fan or series of similar fans shall be developed from tests conducted in accordance with ANSI/AMCA Standard 210, ISO 5801 or other testing standards recognized in AMCA Publication 111. The test method shall be consistent with the test setup of the reference test standard.

14.2.2 Electrical power requirements

When electrical input power is cataloged, the motor shall be operated at the catalog voltage and frequency.

14.3 Test data submittal requirements

14.3.1 Test data

The test data shall be calculated to standard inlet air density and may be calculated to a constant speed.

14.3.2 Test range

The test shall cover the performance range to be cataloged, except that performance may be extrapolated to zero fan static pressure, provided that the airflow so obtained does not exceed the highest test airflow by more than 10%. The portion of the curve obtained by extrapolation shall be a smooth continuation of the curve. In the case of the total or fan static pressure curve, the extrapolation to zero must have the same or smaller radius of curvature as the adjacent portion of the curve, but in no case can it be concave upward.

Extrapolation of the power curve shall be by a straight-line tangent to the adjacent portion of the curve.

14.4 Exhaust/supply units

Axial exhaust/supply or axial combination exhaust/supply/circulate PRVs shall be rated separately for exhaust and supply performance. A single rating may be used provided the performance in both the exhaust and supply modes results in performance, verified by tests, that is within the AMCA Certified Ratings Program tolerances.

Ratings factors may be published to modify the performance rating of an exhaust PRV to obtain the performance rating of the PRV in the supply mode or vice versa. Ratings so obtained may be certified under this program provided that the ratings factors are based on tests of the PRV in both the exhaust and supply modes. It is incumbent on the manufacturer to ensure that performance ratings obtained by using ratings factors are within the AMCA Certified Ratings Program tolerances.

15. Product Ratings Requirements for Jet Fans

15.1 Test setups

15.1.1 Ratings methods

The test figures used for ratings tests shall be those given in ANSI/AMCA Standard 250 or ISO 13350.

15.2 Product configuration

The fan shall be tested as sold and intended for operation in a typical installation. A fan sold and intended for operation with a guard and attenuator shall be tested with the guard and attenuator in place. Published ratings shall indicate whether the effects of a guard and attenuator are included.

15.2.1 Basic conditions

All determinations for jet fan performance are to be based on an unobstructed inlet and outlet except for the structural features of the fan involved and the test rig or appurtenances in place that are shown or described in the published catalog as an integral part of the fan. Where appurtenances are included as part of the fan configuration, they shall be in place during the test and typical of the appurtenances provided to the public.

15.2.2 Non-similar products

The aerodynamic performance of fan assemblies that differ in impeller design (see figures in Annex A), tip diameter and motor physical size shall be determined by actual test. The only interpolation permitted shall be for a speed that lies between the speeds of two actual tests and pitch angles that lie between the pitch angles of two actual tests, conducted according to the previously mentioned conditions.

15.2.3 Airstream restrictions

If the fan is designed with motor, sheaves, bearings and shafts in the airstream, they shall be in place during the test. Sizes of these components shall be as typically provided to the public.

15.3 Test conditions

15.3.1 Test method

The air performance ratings of a fan shall be developed from tests conducted in accordance with ANSI/AMCA Standard 250 or ISO 13350. The test setup shall be consistent with that of the standard referenced.

15.3.2 Electrical power requirements

When electrical input power is cataloged the tested motor shall be operated at the catalog voltage and frequency or where a voltage range is stated, the voltage range shall be the mean voltage. Additionally, the temperature of the motor winding must be stable for each tested operating point.

15.4 Test data submittal requirements

15.4.1 Test data

The test data submitted to AMCA International shall include the raw test data as defined in ANSI/AMCA Standard 250 or ISO 13350. The test standard used shall be identified by issuing organization, number and year of issue.

16. Product Ratings Requirements for Air Curtains

16.1 Conformance to standards

Ratings test setups shall be conducted in accordance with the requirements of ANSI/AMCA Standard 220.

16.2 Product configuration

16.2.1 Basic conditions

All performance ratings determinations for an air-curtain unit or module are to be based on a complete unit with an unobstructed inlet and outlet, except for structural features of the air-curtain unit or module involved or appurtenances in place that are shown or described as being in place as an integral part of the air curtain unit or module in the published catalog. Where appurtenances are included as part of the unit configuration, they shall be in place during the test and typical of the appurtenances provided to the public.

16.2.2 Non-similar products

If in the construction of a module, a series is achieved by varying one aspect of the fan (e.g., the width or diameter of impellers in the same housings, varying blade pitch angle, number of blades or hub-to-tip diameter ratio), the results so obtained are not considered geometrically similar and performance ratings must be determined from a separate test.

16.2.3 Airstream restrictions

If the air-curtain unit or module is designed with motors, sheaves, belts, guards, bearings and shafts in the airstream, they shall be in place during the test. Sizes of these components shall be the same as typically provided to the public.

16.3 Test conditions

16.3.1 Test methods

The air-performance ratings of an air-curtain unit shall be developed from tests conducted in accordance with ANSI/AMCA Standard 220. The test method shall be consistent with the test setup of the reference standard.

16.3.2 Electrical power requirements

When electrical input power is cataloged, the motor shall be operated at the catalog voltage and frequency or, where a voltage range is stated, the voltage range shall be the mean voltage. Additionally, the temperature of the motor windings shall be stable for each tested operating point.

16.3.3 Outlet nozzle

Air-curtain units or modules with adjustable nozzle directions will be tested with the nozzle or vanes directed as close to 15 degrees outward as possible.

16.3.4 Variable volume control

Air-curtain units or modules with variable flow rate control will be tested with the control set for maximum volume.

16.3.5 Heating/cooling sections

If the manufacturer chooses not to catalog an unheated/uncooled air-curtain unit product line, the test made on the heated/cooled units will only be a rating for units with the same arrangements of modules and identical heating/cooling modules.

Units with heating/cooling modules as part of the base will be tested with the heating/cooling section inactive.

16.3.6 Velocity projection

All air-curtain units for which the velocity projection data are to be published shall be tested in accordance with ANSI/AMCA Standard 220 for velocity projection.

16.4 Test data submittal requirements

16.4.1 Test data

Test data shall include the raw test data as defined in ANSI/AMCA Standard 220.

Test data shall be calculated to standard inlet air density. The reduced data shall include the calculated values of performance for airflow rate, average outlet velocity, outlet velocity uniformity, velocity projection and power rating at a constant speed.

16.4.2 Outlet velocity uniformity

The results of the outlet velocity uniformity test shall be presented for each velocity projection in the form of a table. The calculated average of the peak velocities will be shown with the standard deviation as a percentage of the average. Uniformity is 100 less the percentage deviation.

If a unit has multiple nozzles, a table for each nozzle will be presented.

16.4.3 Velocity projection

The results of the velocity projection test will be presented in the form of a table. The distance from the nozzle will be listed with the average core velocity shown.

17. Product Ratings Requirements for Agricultural Ventilation Fans

17.1 Product configuration

17.1.1 Basic conditions

All determinations of agricultural ventilation fan performance are to be made with an unobstructed inlet and outlet except for the structural features of the fan and the appurtenances with which the fan is to be rated and represented or described in a catalog.

17.1.2 Belt tensioning systems

All agricultural belt drive fans shall be furnished and tested with means of maintaining belt tension, cog (timing) belt drive or other drive systems that will maintain running speed during the normal life of the fan.

The drive system tested shall be the same as that furnished on the fan as sold to the end user.

17.1.3 Bearings and shafts

If the fan is provided with bearings, it shall be tested on its own shaft and bearings as typically supplied on the fan provided to the public. The bearing shall include seals and lubricant as typically provided to the public but may be run in to minimize losses associated with new bearings.

17.1.4 Airstream restrictions

If the fan is designed with motors, sheaves, bearings and shafts in the airstream, they shall be in place during the test. Sizes of these components shall be as typically provided to the public.

17.2 Catalog photographs or illustrations

Photographs or illustrations shall be included adjacent to the performance ratings and shall be representative of the fan and assembled fan appurtenances for which ratings are certified.

17.3 Test conditions

17.3.1 Test methods

The air performance ratings of a fan shall be developed from tests conducted in accordance with ANSI/AMCA Standard 210, ISO 5801 or other testing standards recognized in AMCA Publication 111. The test method shall be consistent with the test setup of the reference test standard.

17.3.2 Power measurement

The motor input power (in W) shall be measured for each test point.

17.3.3 Test voltage

Agricultural ventilation fans shall be tested at the motor nameplate voltage. If the motor nameplate voltage is shown as 208 - 230 volts and the fan is to be rated at both voltages, the fan shall be tested at both voltages.

17.3.4 Motor calibration

Motor calibrations shall be performed at the voltage and frequency to be used for the fan test. Motor calibrations shall be performed by the AMCA testing laboratory, the motor manufacturer or by an AMCA-accredited laboratory.

The motor calibrator shall provide a certified calibration curve complete with values of hot efficiency.

17.4 Test data submittal requirements

17.4.1 Test data

The test data shall be calculated to standard inlet air density and may be calculated to a constant speed.

The data shall include the calculated values of airflow, fan static pressure, motor input power, cfm/W and the speed at each test point.

17.4.2 Description and related data

A complete description of the fan tested, including any/all appurtenances in place as tested, shall be submitted with the test data.

A complete identification of the motor used on the test fan, including the manufacturer and model number, shall be submitted with the test data. If the motor was calibrated, the calibration curve for the motor shall also be submitted.

17.4.3 Dimensional data

Basic dimensional data on the test fan shall include appurtenances.

17.5 Alternate motors

Other makes or models of motors may be used as alternates to the motor used on the test fan provided they have equal or higher efficiency. Alternate motors may be listed at the time of the initial certification, and additions or changes to the list of alternate motors can be made after certification. AMCA International shall be notified prior to the use of additional alternate motors or changes to listed motors. Equivalency of alternate motors shall be substantiated by submitting the calibration curve of the alternate motor showing equal or better efficiency compared with the test fan motor or via a test of the fan with the alternate motor verifying equal or better cfm/W performance.

18. Product Ratings Requirements for Positive Pressure Ventilators

18.1 Test setups

Rating test setup shall be conducted in accordance with the requirements of ANSI/AMCA Standard 240.

18.2 Product configuration

18.2.1 Basic conditions

All determinations of PPV performance are to be made with an unobstructed inlet and outlet except for the structural features of the PPV and the appurtenances with which the PPV are to be rated and represented or described in the published catalog. Where appurtenances are included as part of the fan configuration, they shall be in place during the test and typical of the appurtenances provided to the public.

18.2.2 Fume exhaust systems

All gasoline powered PPVs shall be furnished and tested with means for a direct, closed connection between the PPV engine exhaust and the laboratory exhaust removal system. This piece shall include a cylindrical section with an opening having an outside diameter of 41 mm (1.625 in.) for connection with the exhaust removal system and be constructed and installed so interference with airflow near the PPV inlet and outlet is minimized.

18.2.3 Belt tensioning systems

All belt drive PPVs shall be furnished and tested with means of maintaining belt tension, cog (timing) belt drive or other drive systems that will maintain running speed during the normal life of the PPV.

The drive system shall be the same as that furnished on the PPV as sold to the end user.

18.2.4 Bearings and shafts

If the PPV is provided with bearings, it shall be tested on its own shaft and bearings as typically supplied on the PPV provided to the public. The bearing shall include seals and lubricant as typically provided to the public.

18.2.5 Airstream restrictions

If the PPV is designed with motors, sheaves, bearings and shafts are in the airstream, they shall be in place during the test. Sizes of these components shall be as typically provided to the public.

18.3 Catalog photographs or illustrations

If photographs or illustrations are included adjacent to the performance ratings, they shall be representative of the assembled PPV appurtenances for which ratings are certified.

18.4 Test conditions

18.4.1 Test methods

The air-performance ratings of a PPV shall be developed from tests conducted in accordance with ANSI/AMCA Standard 240.

18.4.2 Test speed

A PPV model shall be tested at the speed obtained by its motor or engine.

18.4.3 Test density

A PPV shall be tested under atmospheric conditions in which the air density is within the range of 1.14 to 1.20 kg/m³ (0.071 to 0.075 lbm/ft³).

18.4.4 Drive method

PPVs shall be tested while driven by their own motor or engine.

18.5 Test data submittal requirements

18.5.1 Test data

The test data submitted to AMCA International shall include the raw data as defined in ANSI/AMCA Standard 240. The test standard shall be identified by issuing organization, number and year of issue.

18.5.2 Description and related data

A complete description of the PPV tested, including any/all appurtenances in place, shall be submitted with the test data.

18.6 Alternate motors/engines

Alternate motors are permitted. However, alternate engines are not.

19. Product Ratings Requirements for ERVs/HRVs

19.1 Definitions

19.1.1 ERV

An ERV/HRV is an assembly of fans, controls and energy recovery elements used to exhaust air from the interior space, bring in air from outdoors and transfer thermal energy between the two isolated airstreams.

19.1.2 ERV port nomenclature

The four ports of an ERV/HRV as depicted in Figure 19.1 are:

1. Supply air inlet (air from outside)
2. Supply air outlet (air from equipment to space)
3. Exhaust air inlet (air from space to equipment)
4. Exhaust air outlet (air from equipment to outside)

19.1.3 Gross airflow

Gross airflow, the total airflow measured at an inlet or outlet, from an ERV/HRV inlet/outlet may include casing leakage and cross-leakage.

19.1.4 Electrical power requirements

When electrical input power is cataloged, the tested motor on the supply side shall be operated at the catalog voltage and frequency, or, where a voltage range is stated, the voltage range shall be the mean voltage. Additionally, the temperature of the motor winding must be stable for each tested operating point.

19.2 Test conditions

The test range of external fan static pressures on port 2 to determine air performance ratings for gross supply airflow also shall be used to determine air performance ratings for gross exhaust airflow to port 3. Gross supply air performance ratings (airflow, pressure and power) are at port 2 with ports 1, 3 and 4 at manufacturer specified fan static pressures; ports 1 and 3 are equal. Gross exhaust air performance ratings (airflow, pressure and power) are at port 3 with ports 1, 2 and 4 at manufacturer specified fan static pressures; ports 2 and 4 are equal.

19.3 Catalog requirements

19.3.1 Gross supply airflow

19.3.1.1 Statements

The following statement shall be shown immediately adjacent to the ratings tables, graphs or charts:

“Air-performance ratings for gross supply airflow are from port 2.”

19.3.1.2 Published ratings

External fan static pressures on ports 1, 3 and 4.

19.3.2 Gross exhaust airflow

19.3.2.1 Statements

The following statement shall be shown immediately adjacent to the ratings tables, graphs or charts:

“Air-performance ratings for gross exhaust airflow are from port 3.”

19.3.2.2 Published ratings

External fan static pressures on ports 1, 2 and 4.

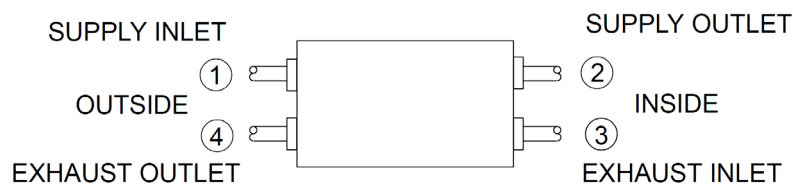

Figure 19.1 — Diagram of Generic ERV

20. Product Ratings Requirements for Circulating Fans

20.1 Test setups

20.1.1 Conformance to standards

Ratings test setups shall be conducted in accordance with the requirements of ANSI/AMCA Standard 230.

20.1.2 Ratings methods

The test figures used for ratings tests shall be those given in ANSI/AMCA Standard 230.

20.2 Product configuration or examples of installation

The fan shall be tested as-sold and as intended for operation in a typical installation. A fan sold and intended for operation with a guard shall be tested with the guard in place. Published ratings shall indicate whether the effect of a guard is included.

20.2.1 Basic conditions

All determinations for air-circulating fan performance are to be based on an unobstructed inlet and outlet except for the structural features of the fan involved and the test rig or appurtenances that are shown or described as being in place as an integral part of the fan described in the published catalog. Where appurtenances are included as part of the fan configuration, they shall be in place during the test and typical of the appurtenances provided to the public.

20.2.2 Non-similar products

The aerodynamic performance of fan assemblies that differ in impeller design (see figures in Annex A), motor, model number and/or tip diameter and motor physical size shall be determined by an actual test. The only performance interpolation permitted shall be for a speed, which lies between the speeds of two actual tests, conducted according to the above conditions.

20.2.3 Airstream restrictions

If the fan is designed with motor, sheaves, bearings and shafts in the airstream, they shall be in place during the test. Sizes of these components shall be as typically provided to the public.

20.3 Test conditions

20.3.1 Test methods

The air performance ratings of a fan shall be developed from tests conducted in accordance with ANSI/AMCA Standard 230 or other test standards as noted in this section. The test setup shall be consistent with the test setup of the standard referenced. In the case where a customer can change the pitch of the ceiling fan blades, the ratings shall be based on the maximum pitch available to the customer.

20.3.2 Test speed

A circulating fan shall be tested at the speeds indicated in ANSI/AMCA Standard 230, Section 8.2.4.

20.3.3 Test voltage

Test voltage shall be in conformance with the requirements of ANSI/AMCA Standard 230, Section 6.3.3.

The supply voltage shall be:

- 120 V if the ceiling fan's minimum rated voltage is 120 V or the lowest-rated voltage range contains 120 V.
- 240 V if the ceiling fan's minimum rated voltage is 240 V or the lowest-rated voltage range contains 240 V.
- The ceiling fan's minimum rated voltage (if a voltage range is not given) or the mean of the lowest-rated voltage range, in all other cases.

Fans rated for operation with only single- or multi-phase power supply shall be tested with single- or multi-phase electricity, respectively. Fans capable of operating with single- and multi-phase electricity shall be tested with multi-phase electricity.

20.4 Test data submittal requirements

The test data submitted to AMCA International shall include all items listed in Section 10 of ANSI/AMCA Standard 230. The test standard used shall be identified by issuing organization, number and year of issue.

21. Product Ratings Requirements for Induced Flow Fans

21.1 Basic conditions

All determinations for fan performance ratings are to be based on an unobstructed inlet and outlet except for the structural features of the fan involved or appurtenances in place that are shown or described as being in place as an integral part of the fan in the published catalog. Where appurtenances are included as part of the fan configuration, they shall be in place during the test and typical of the appurtenances provided to the public. The allowances found in Section 11.1 for centrifugal fans and Section 12.1 for axial fans shall be applicable for induced-flow fans.

21.2 Test setups

Induced-flow fans shall be tested in accordance with ANSI/AMCA Standard 260.

21.3 Electrical power requirements

When electrical input power is cataloged, the tested motor shall be operated at the catalog voltage and frequency, or, where a voltage range is stated, the voltage range shall be the mean voltage. Additionally, the temperature of the motor winding must be stable for each tested operating point.

21.4 Test data submittal requirements

21.4.1 Test data

The test data submitted to AMCA International shall include the raw test data as defined in ANSI/AMCA Standard 260.

The test data shall be calculated to standard inlet air density and may be calculated to a constant speed.

21.4.2 Test range

The test shall cover the performance range to be cataloged, except that performance may be extrapolated to zero fan static pressure provided that the airflow so obtained does not exceed the highest test airflow by more than 10%. The portion of the curve obtained by extrapolation shall be a smooth continuation of the curve. In the case of the fan static pressure curve, the extrapolation to zero must have the same or smaller radius of curvature as the adjacent portion of the curve, but in no case can it be concave upward.

Extrapolation of the power curve shall be via a straight-line tangent to the adjacent portion of the curve.

22. Product Ratings Requirements for Large-Diameter Ceiling Fans

22.1 Test setups

22.1.1 Conformance to standards

For ceiling fans with impeller diameters greater than 2.13 m (7 ft), the rating test setups shall be conducted in accordance with the requirements of ANSI/AMCA Standard 230, 10 CFR 430 and Section 325(ff)(6) of the Energy Policy and Conservation Act (42 U.S.C. 6295(ff)(6)).

22.2 Product configuration or examples of installation

The fan shall be tested as sold and as intended for operation in a typical installation. A fan sold and intended for operation with a fan guard shall be tested with the guard in place. Published ratings shall indicate whether the effect of a fan guard is included in the ratings.

22.2.1 Basic conditions

All determinations for air circulating fan performance are to be based on an unobstructed inlet and outlet except for the structural features of the fan involved and the test rig or the appurtenances in place that are shown or described as being in place as an integral part of the fan described in the published catalog. Where appurtenances are included as part of the fan configuration, they shall be in place during the test and typical of the appurtenances provided to the public.

22.2.2 Non-similar products

The aerodynamic performance of fan assemblies that differ in impeller design (see figures in Annex A), impeller diameter and motor physical size shall be determined by an actual test. The only performance interpolation permitted shall be for a fan speed, which lies between the fan speeds of two actual tests, conducted according to the above conditions.

22.2.3 Airstream restrictions

If the fan is designed with a motor, bearings and shafts in the airstream, they shall be in place during the test. Sizes of these components shall be as typically provided to the public.

22.3 Test methods

The air-performance ratings of a fan shall be developed from tests conducted in accordance with ANSI/AMCA Standard 230; 10 CFR Part 430; and Section 325(ff)(6) of the Energy Policy and Conservation Act (42 U.S.C. 6295(ff)(6)) for aerodynamic performance ~~and 10 CFR 430 and IEC 62301 for standby power consumption~~. The test setup shall be consistent with the test setup of the standard referenced. In the case where a customer can change the pitch of the ceiling fan blades, the ratings shall be based on the maximum pitch available to the customer.

22.3.1 Test speed

Each base model will be tested at a minimum of two test points: the maximum impeller rotational speed (high speed) and 40 % speed or the nearest speed that is not less than 40 % speed. Additional test speeds are allowed. The test speed shall be within $\pm 1\%$ or 1 rpm of the required speed, whichever is greater.

22.3.2 Test voltage

For ceiling fans with impeller diameters larger than 2.13 m (7 ft), the supply voltage shall be as follows:

- 120 V if the ceiling fan's minimum rated voltage is 120 V or the lowest-rated voltage range contains 120 V.
- 240 V if the ceiling fan's minimum rated voltage is 240 V or the lowest-rated voltage range contains 240 V.
- The ceiling fan's minimum rated voltage (if a voltage range is not given) or the mean of the lowest-rated voltage range, in all other cases.

Ceiling fans with impeller diameters larger than 2.13 m (7 ft) rated for operation with only single-phase or polyphase power supply shall be tested with single-phase or polyphase electricity, respectively. Ceiling fans with impeller diameters larger than 2.13 m (7 ft) capable of operating with single-phase and polyphase electricity shall be tested with polyphase electricity.

22.4 Test data submittal requirements

The test data submitted to AMCA International shall include all items listed in Section 10 of ANSI/AMCA Standard 230. The test standard used shall be identified by issuing organization, number and year of issue. The test data submitted to AMCA International shall also include all performance data required by 10 CFR Part 430; Section 325(ff)(6) of the Energy Policy and Conservation Act (42 U.S.C. 6295(ff)(6)); and all items listed in Section 10 of ANSI/AMCA Standard 230. For test data required by 10 CFR Part 430, the submitted data shall be for a minimum of two samples. Airflow rate, fan system input power, and CFEI rating shall be determined in accordance with 10 CFR Part 429, Subpart B; Section 429.32 and Section 325(ff)(6) of the Energy Policy and Conservation Act (42 U.S.C. 6295(ff)(6)).

Annex A

Dimensional Requirements (Normative)

A.1 General requirements

When submitting test data, the manufacturer shall submit dimensional information for the test units. They also shall submit dimensional information for all units that will be rated based on geometric similarity with a test unit. Dimensional data on both the impeller and fan unit shall be submitted.

The dimensional data shall be in sufficient detail to allow AMCA International staff to verify that the precertification test unit and check test unit are physically in accordance with the dimensional data submitted.

The following illustrations are intended to provide guidelines for the minimum dimensional information required. These illustrations are not intended to represent all possible fan types and configurations.

For products that are different than those shown, it is necessary to provide dimensional detail for the airflow passages and impellers similar to that shown in the illustrations.

It is incumbent on the manufacturer to establish and maintain geometric similarity between the test unit and larger units that are rated based on the test-unit performance data and fan laws.

A.1.1 Tolerance and precision

Absolute proportionality is not always required to maintain the validity of calculated performance using the fan laws. Exceptions to strict proportionality are listed below.

- Other than the items listed in the product ratings requirements sections and below, all design dimensions shall be proportional within $\pm 1\%$.
- The dimensions of the following items may be greater than those derived from proportionality:

<i>P</i>	Panel size
<i>T</i>	Length to belt tube
<i>K</i>	Orifice depth
<i>R</i>	Orifice radius
<i>M</i>	Height above roof
<i>I</i>	Inside curb
<i>F</i>	Discharge size or area
<i>Q</i>	Shaft height above base
<i>S</i>	Shaft diameter, if shaft extends through box
<i>V</i>	Hood size
<i>X</i>	Wind band diameter
- The number of blades, *N*, shall be equal for all proportional fans.
- The number of vanes, *NV*, shall be equal for all proportional fans.
- The belt tube dimension, *J*, may be less than that derived from proportionality or up to 7½% larger.
- The hood height above the roof, *M*, may be greater than that derived from proportionality. The hood depth, *N*, may be less than that derived from proportionality provided that the sum of the *N* and *M* dimensions is proportional or greater.

A.1.2 Illustrations

In the illustrations, the term “size” is understood to mean diameter, length or width as appropriate for the product being described.

- A Diameter at Blade Tip
- B Diameter at Blade Heel
- W Blade Width at Discharge
- D Minimum Diameter at Inlet Cone
- N Number of Blades

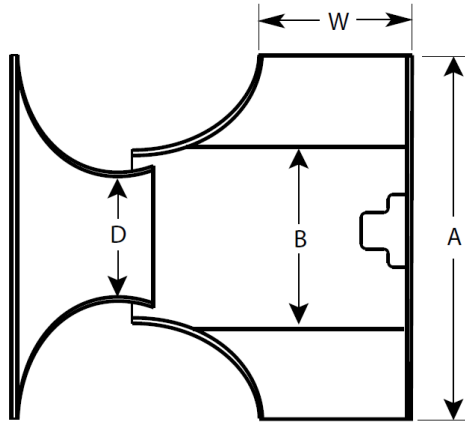

Figure A.1 — Backward Inclined Centrifugal Impeller

- A Diameter at Blade Tip
- B Diameter at Blade Heel
- W Blade Width at Discharge
- D Minimum Diameter at Inlet
- N Number of Blades

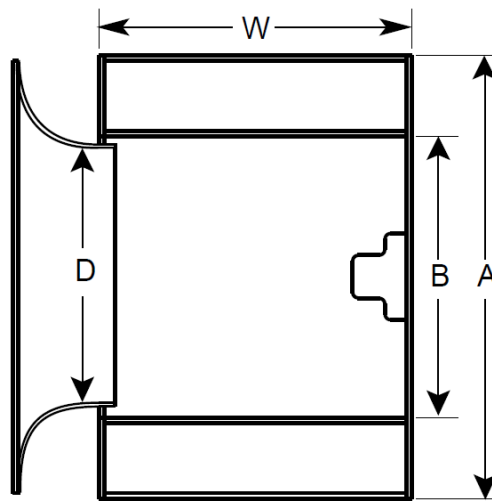

Figure A.2 — Forward Curved Centrifugal Impeller

- A Diameter at Blade Tip
- B Diameter at Blade Heel
- W Blade Width at Discharge
- D Inlet Diameter
- N Number of Blades

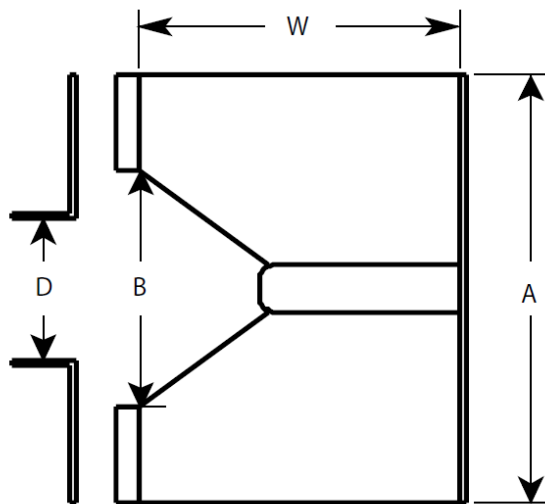

Figure A.3 — Radial Centrifugal Impeller

- A Major Diameter at Discharge
- A_1 Minor Diameter at Discharge
- B Major Diameter at Blade Heel
- W Blade Width at Discharge
- D Minimum Diameter at Inlet Cone
- N Number of Blades

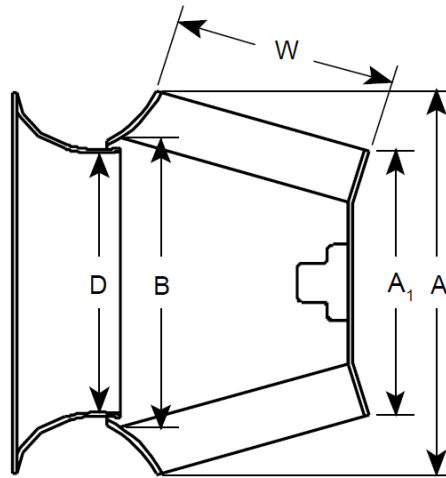

Figure A.4 — Mixed Flow Impeller

- A Diameter at Blade Tip
- H Hub Diameter
- G Blade Width at Discharge
- α Pitch Angle at Tip or at a Designated Radius
- N Number of Blades

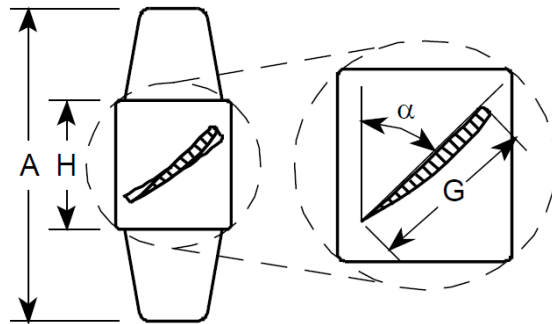

Figure A.5 — Vaneaxial Propeller

- A Diameter at Blade Tip
- H Hub Diameter
- G Blade Width at Discharge
- α Pitch Angle at Tip or at a Designated Radius
- N Number of Blades

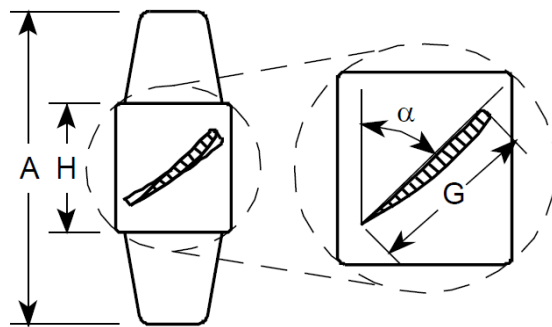

Figure A.6 — Tubeaxial Propeller

- A Diameter
- H Blade Root Diameter
- G Blade Width at a Designated Radius
- α Pitch Angle at a Designated Radius
- N Number of Blades

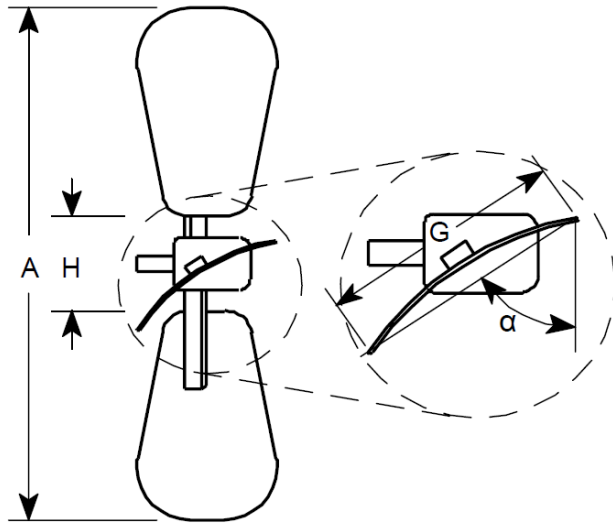
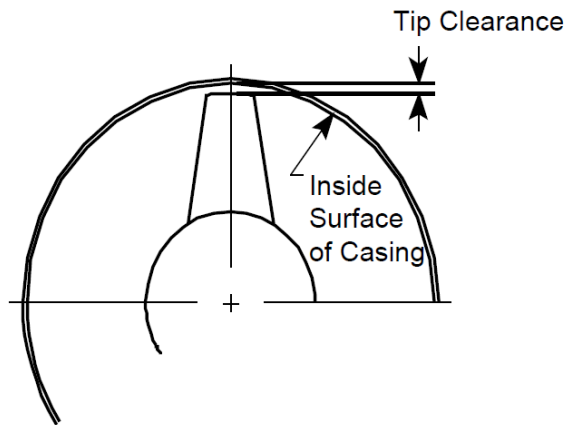

Figure A.7 — Fabricated Propeller

Design tip clearance is defined as the difference between the design radius of the impeller and the design internal radius of the fan casing. Measured tip clearance is defined as the average of the tip clearance measurement for all blades taken at eight locations (45° intervals) around the fan casing.



Note: This dimension is not required for proportionality.

Figure A.8 — Tip Clearance

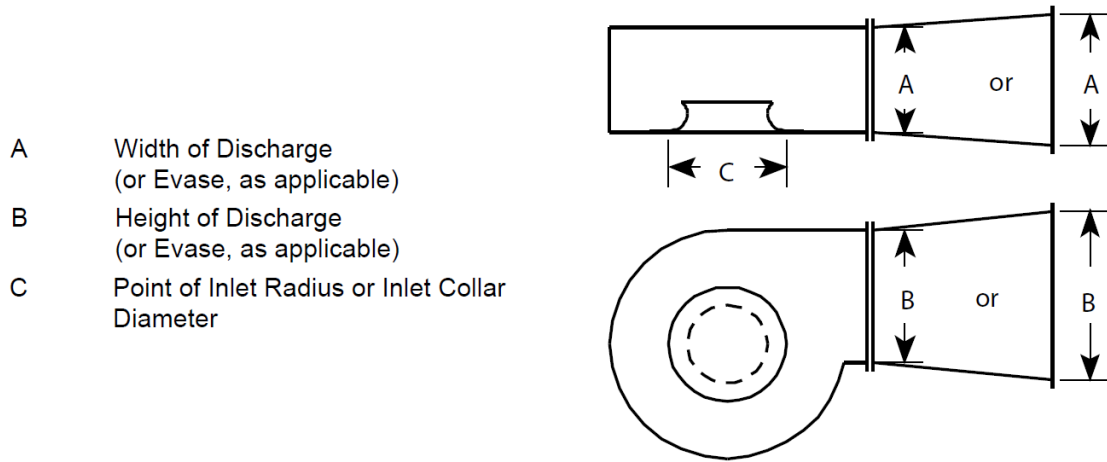

Figure A.9 — Centrifugal Fan Housing

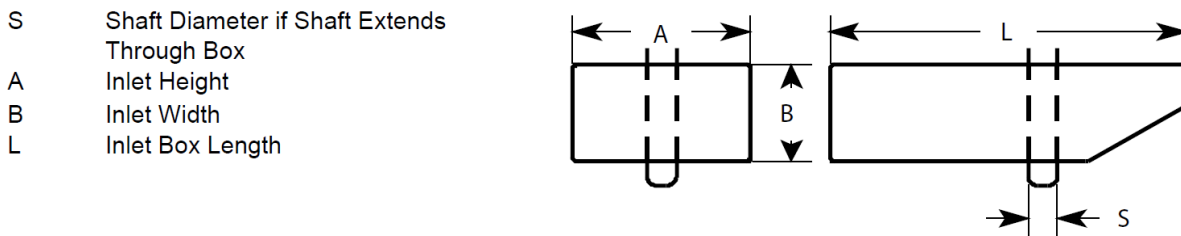

Figure A.10 — Inlet Box

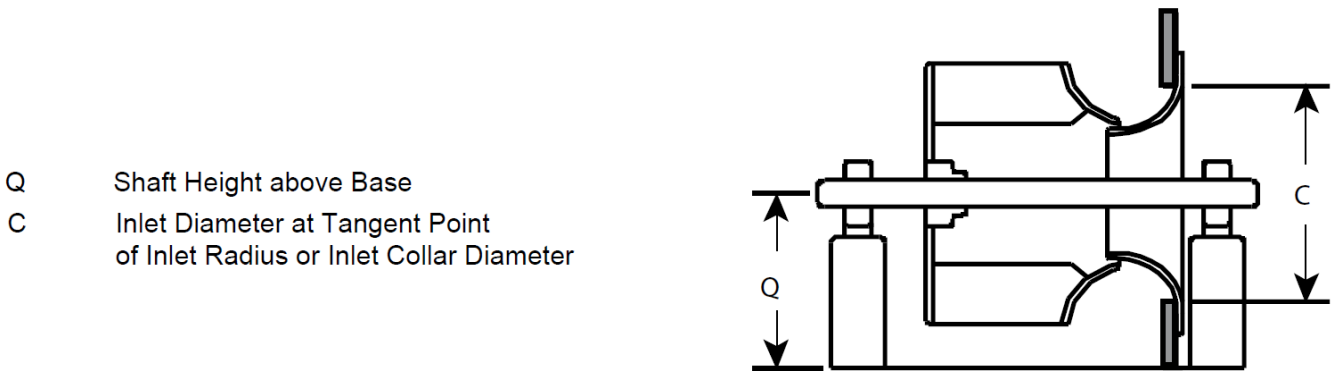

Figure A.11 — Arrangement 3 Plenum Fan

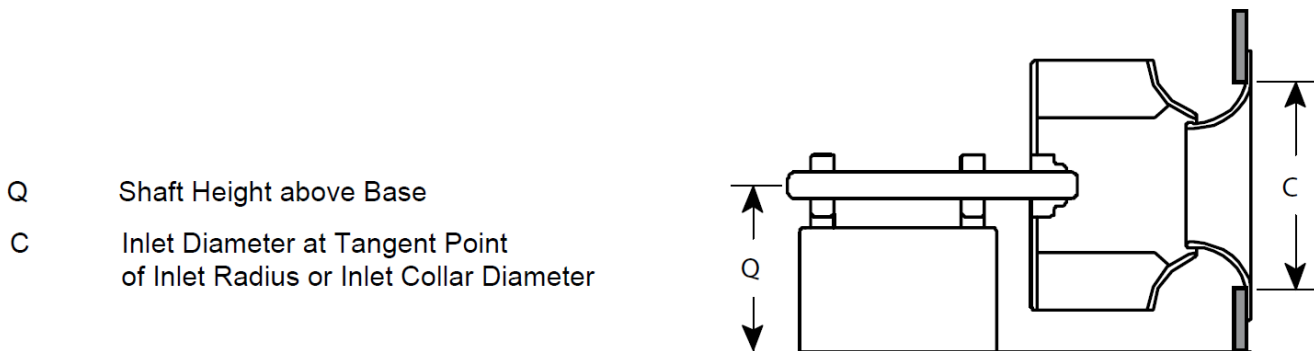

Figure A.12 — Arrangement 1 Plenum Fan

- P Panel Size
- C Inlet Diameter at Tangent Point of Inlet Radius or Inlet Collar Diameter

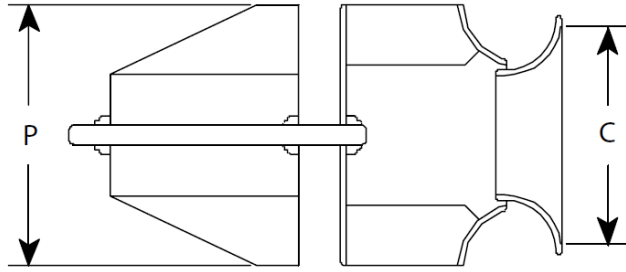
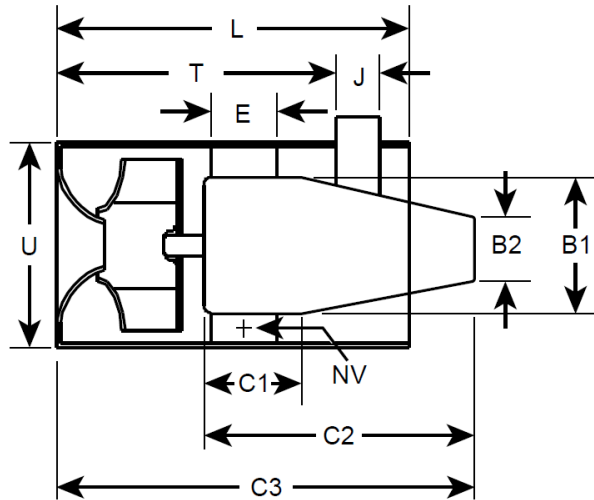

Figure A.13 — Plug Fan

- L Tube Length
- T Length to Belt Tube
- J Belt Tube Size
- E Length of Vanes
- U Drum Diameter or Square Size
- B2 Interior Drum Size at Discharge
- B1 Interior Drum Size
- NV Number of Vanes
- C1 Center Body Front Section
- C2 Center Body Length
- C3 Length to End of Center Body



Note: If C3 is less than or equal to L, then L does not need to be proportional.

Figure A.14 — Inline Centrifugal Fan Belt Drive

- L Tube Length
- T Length to Belt Tube
- J Belt Tube Size
- E Length of Vanes
- U Drum Diameter or Square Size
- B Interior Drum Size at Discharge
- NV Number of Vanes
- C2 Center Body Length
- C3 Length to End of Center Body

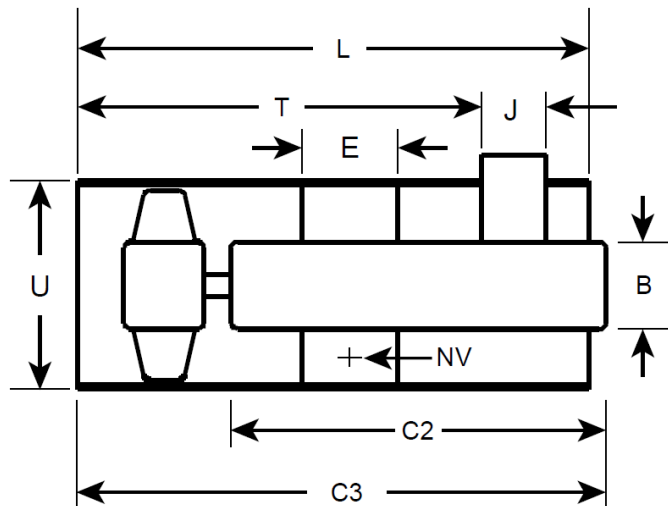

Note: If C3 is less than or equal to L, then L does not need to be proportional.

Figure A.15 — Vaneaxial Fan Belt Drive

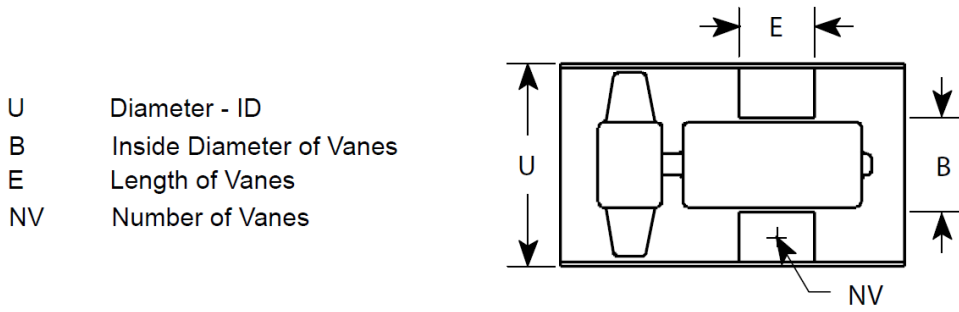

Figure A.16 — Vaneaxial Fan Direct Drive

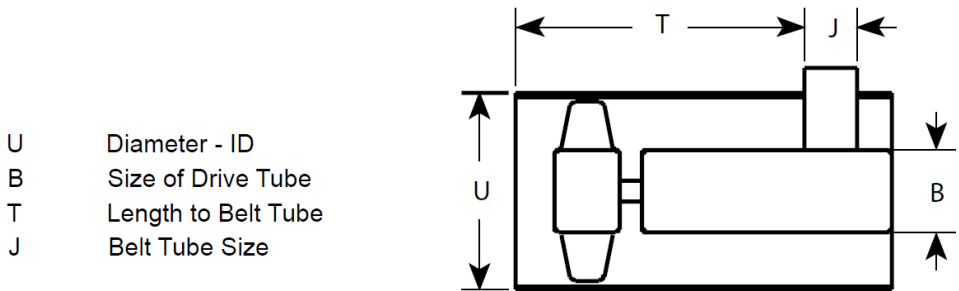

Figure A.17 — Tubeaxial Fan Belt Drive

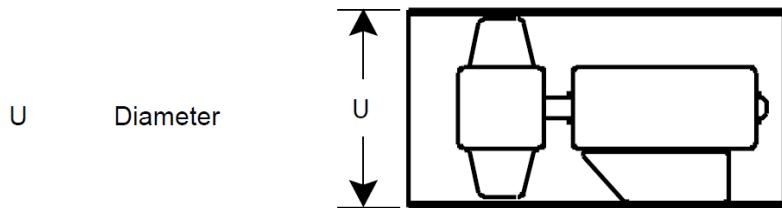

Figure A.18 — Tubeaxial Fan Direct Drive

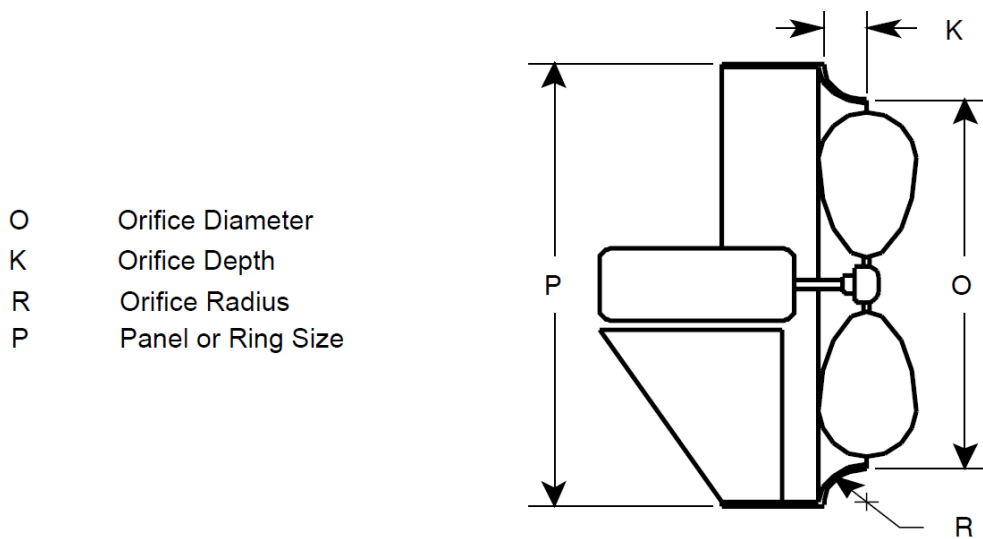

Figure A.19 — Propeller Fan

- N Hood Height
- V Hood Diameter
- C Inlet Collar Diameter
- I Recommended Inside Curb Dimension
- M Minimum Height Above Roof
- D_1 Inside Diameter of Discharge
- D_2 Outside Diameter of Discharge

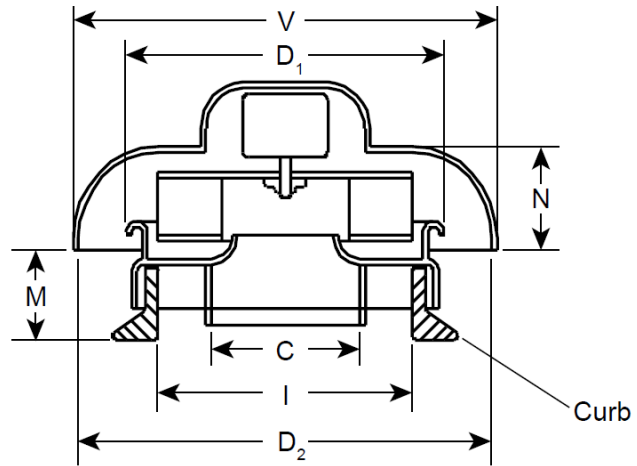

Figure A.20 — Centrifugal PRV Exhaust-Down Discharge

- V Hood Diameter
- C Inlet Collar Diameter
- I Recommended Inside Curb Dimension
- D_1 Inside Diameter of Discharge
- D_2 Outside Diameter of Discharge

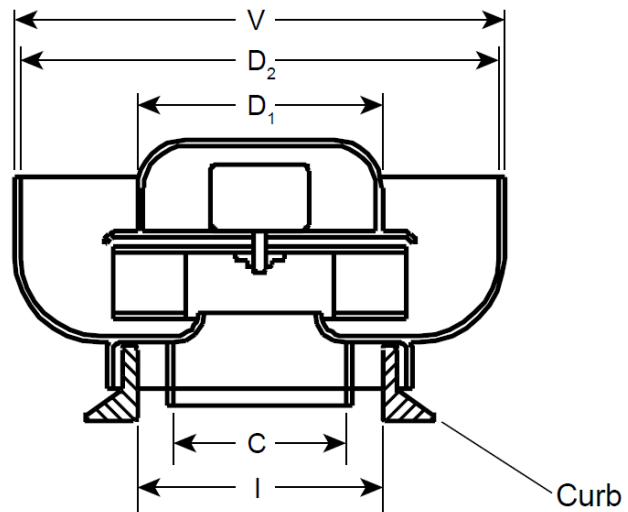

Figure A.21 — Centrifugal PRV Exhaust-Up Discharge

- V Hood Diameter
- C Inlet Collar Diameter
- I Recommended Inside Curb Dimension
- M Minimum Height Above Roof
- O Orifice Diameter
- K Orifice Depth
- R Orifice Radius
- D_1 Inside Diameter of Discharge
- D_2 Outside Diameter of Discharge

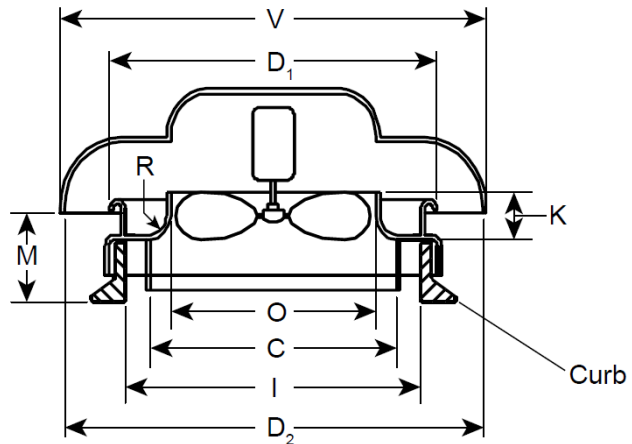

Figure A.22 — Axial PRV Supply or Exhaust

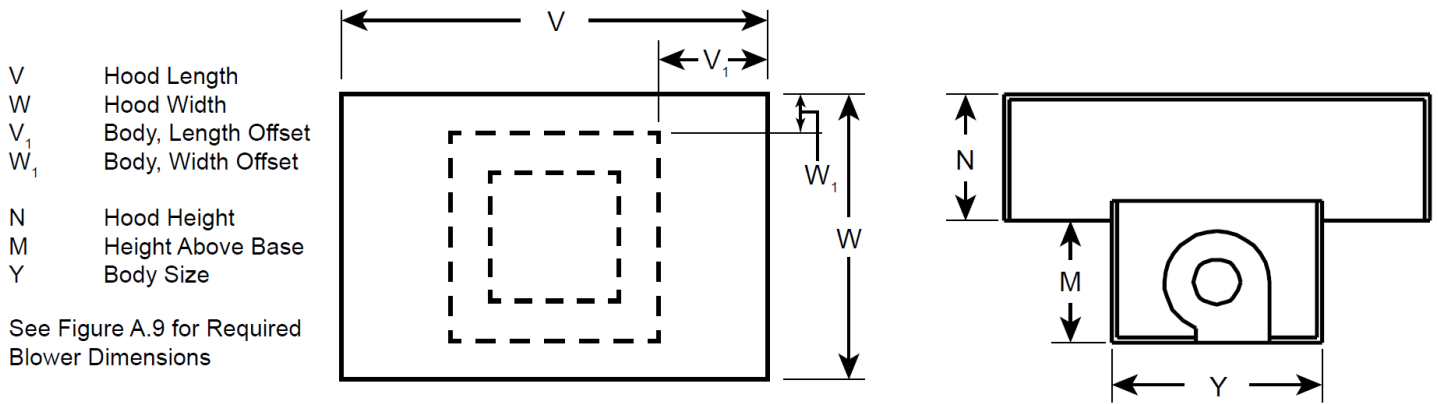

Figure A.23 — Centrifugal Supply PRV

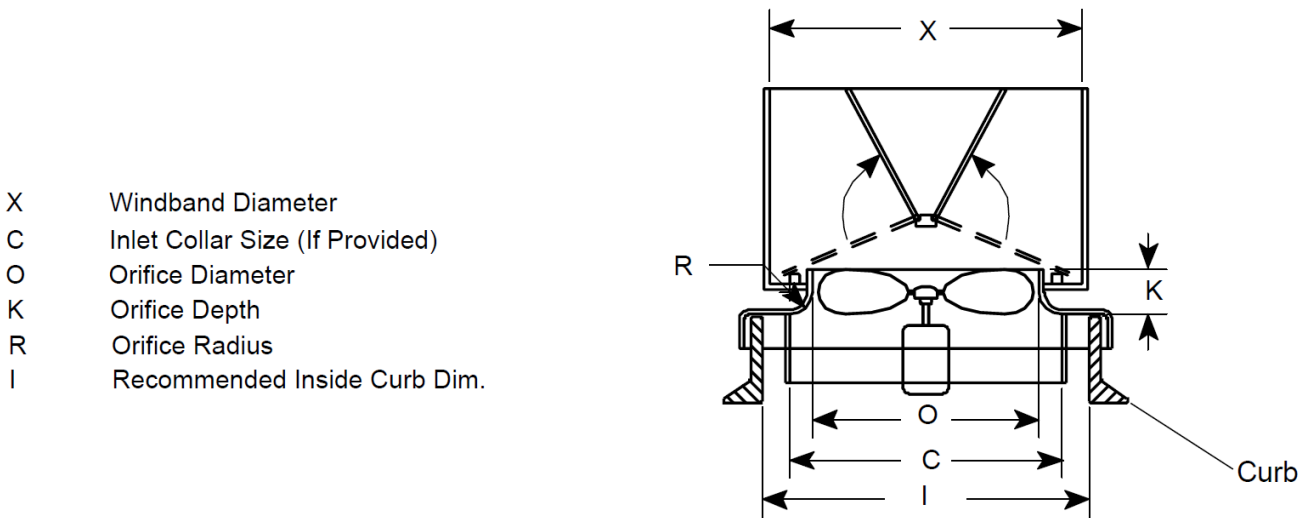

Figure A.24 — Axial Upblast PRV

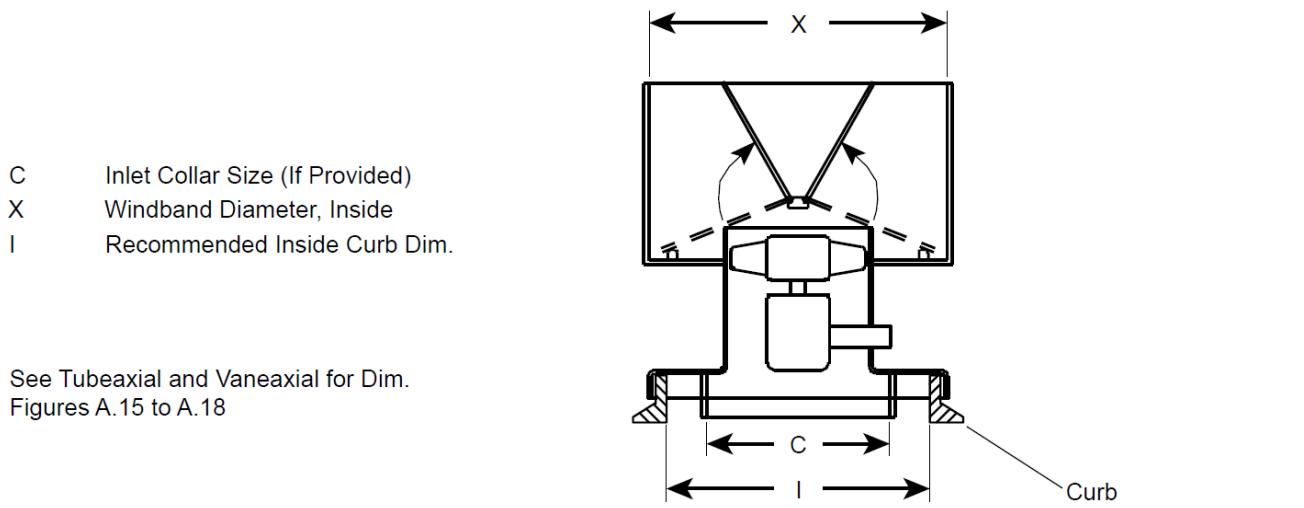
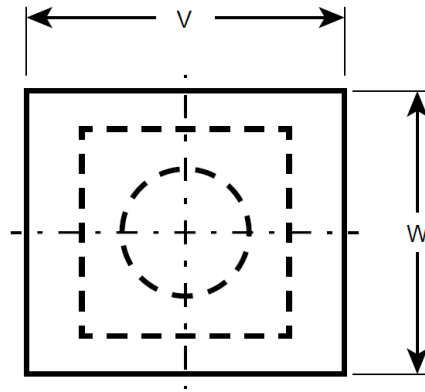

Figure A.25 — Axial Upblast PRV

- V Hood Length
- W Hood Width
- N Hood Height
- M Height Above Base
- C Inlet Collar Size (If Provided)
- I Recommended Inside Curb Dimension



See tubeaxial Figure A.17 and A.18
for Required Fan Dimensions

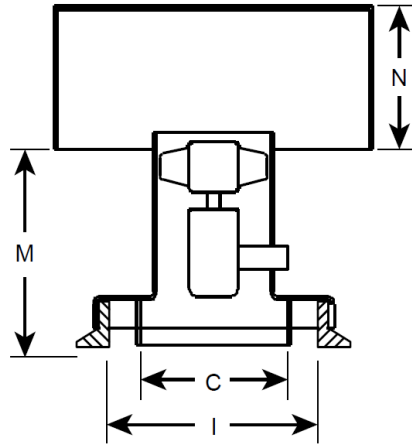
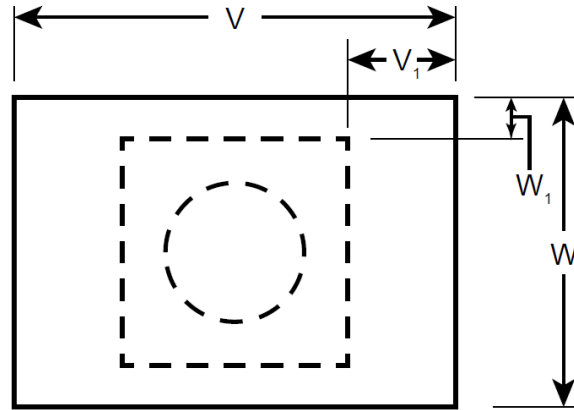

Figure A.26 — Axial Supply/Exhaust PRV

V Hood Length
 W Hood Width
 V_1 Body, Length Offset
 W_1 Body, Width Offset



N Hood Height
 M Height Above Base
 R Orifice Radius
 K Orifice Depth
 O Orifice Diameter
 Y Body Size

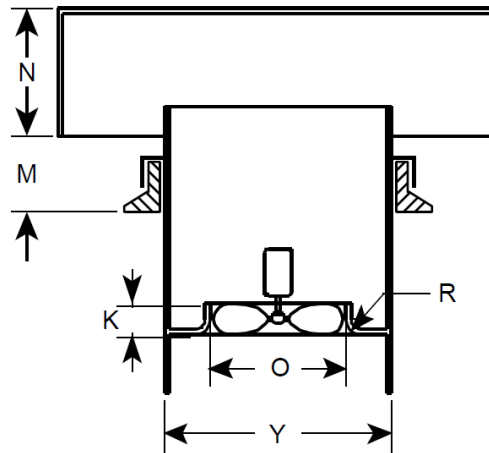

Figure A.27 — Combination PRV Exhaust-Supply-Circulate

Y Body Size
 K Orifice Depth
 O Orifice Depth
 R Orifice Radius
 X Wind Band Diameter, Inside

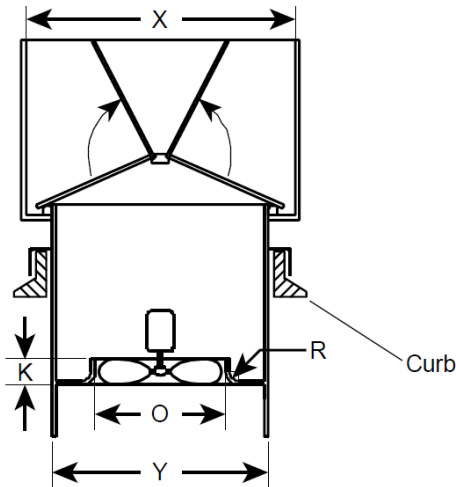
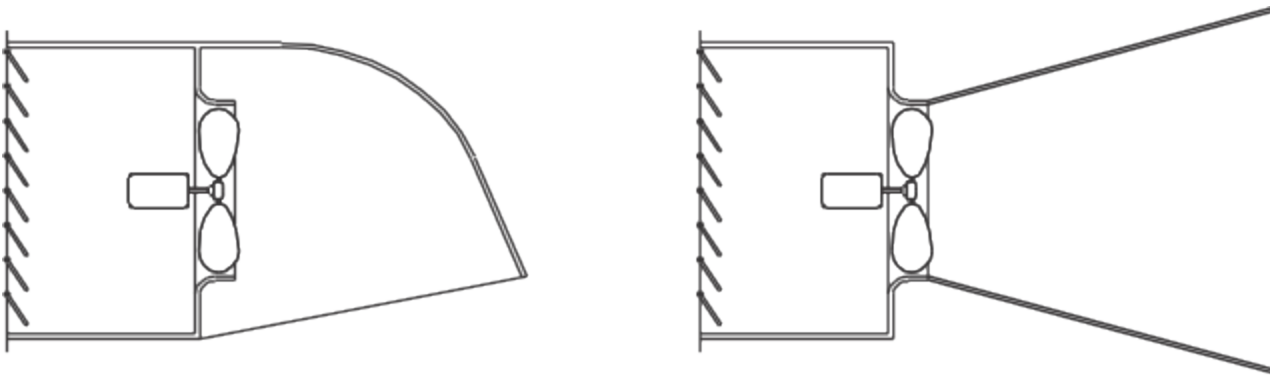
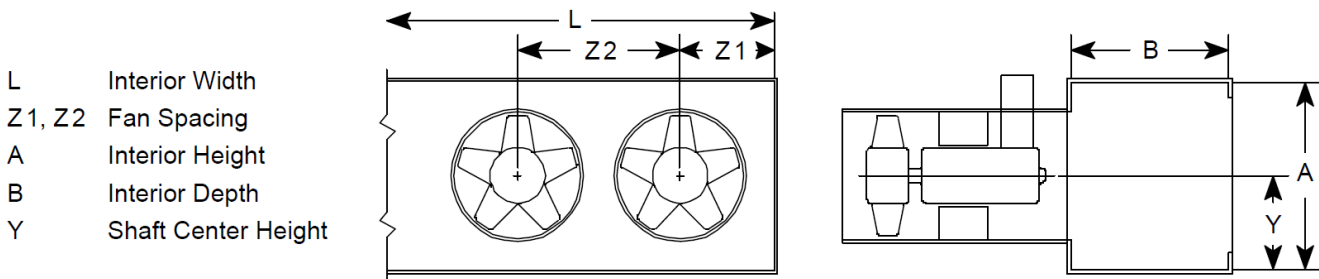

Figure A.28 — Combination PRV Exhaust/Circulate



See Figure A.19 for Dimensional Requirements for Propeller Fans
 Provide All Dimensions Required to Define Inlet and/or Outlet Appurtenances

Figure A.29 — Agricultural Ventilation Fans



See Tubeaxial and Vaneaxial Figures A.15, A.16, A.17, and A.18 for Required Fan Dimensions

Figure A.30 — Vane/Tubeaxial Air Curtain

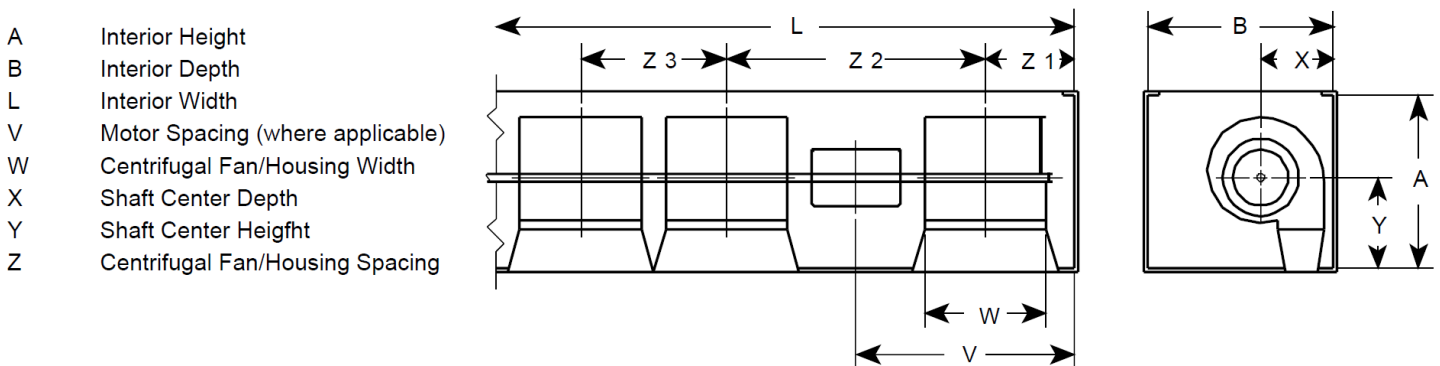

Figure A.31 — Centrifugal/Tangential Air Curtain

- L Interior Width
- Z1, Z2 Axial Fan Spacing
- W Impeller Diameter at Blade Tip
- A Interior Height
- B Interior Depth
- K Orifice Depth
- R Orifice Radius
- O Min. Diameter of Inlet Cone
- Y Shaft Center height

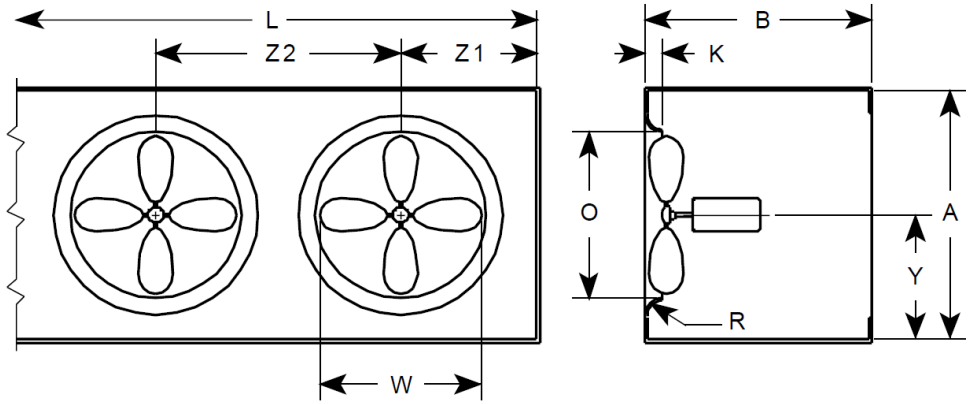

Figure A.32 — Axial Air Curtain

- A Housing Dimensions
- B Inlet Length
- C Outlet Length
- K Inlet Orifice Depth
- O Minimum Diameter of Inlet Orifice

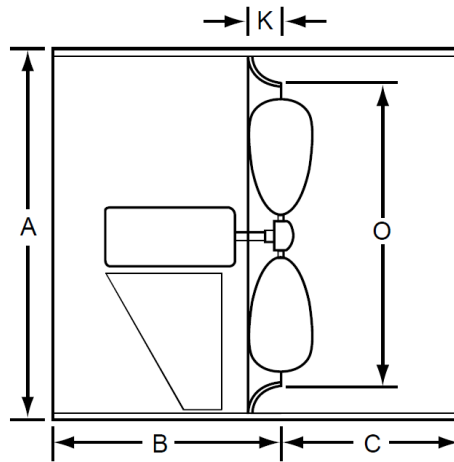

Figure A.33 — Circulating Fan

- N1 Number of Rings
- N2 Number of Radial Supports
- T1 Ring Thickness
- T2 Radial Support Thickness
- S1 Ring Spacing

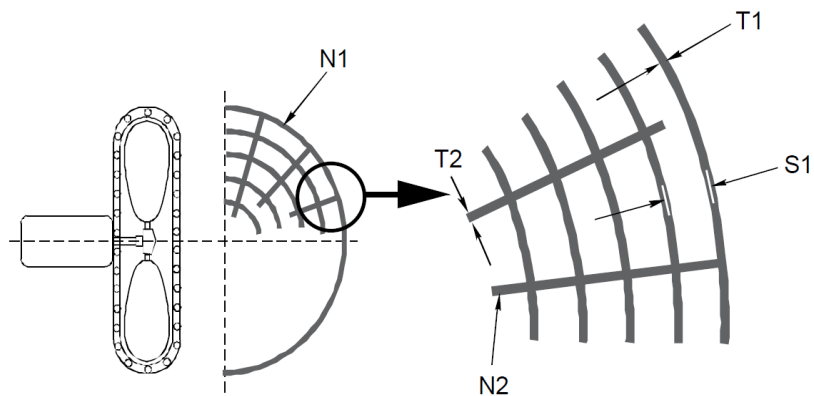
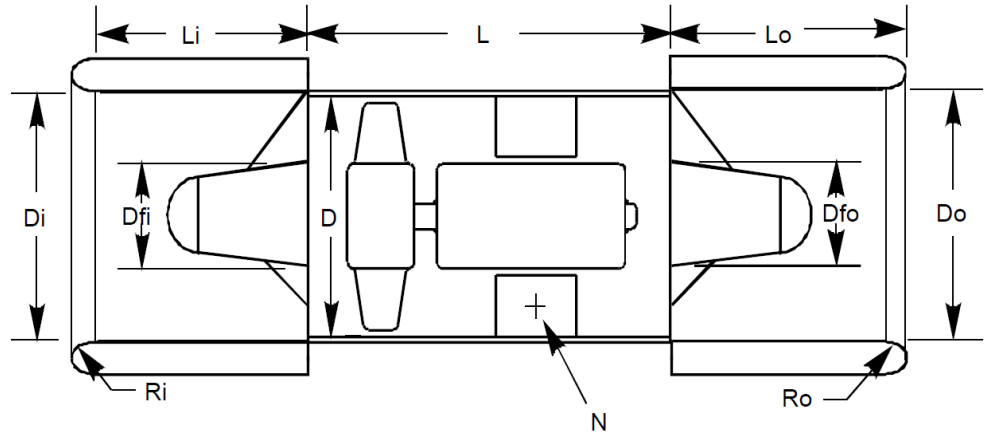

Figure A.34 — Circulating Fan Head with Guard

- L Fan Length
- Li Inlet Silencer Length
- Lo Outlet Silencer Length
- D Fan Diameter
- Di Inlet Silencer Diameter
- Do Outlet Silencer Diameter
- Dfi Inlet Fairing Diameter
- Dfo Outlet Fairing Diameter
- Ri Inlet Bell Radius
- Ro Outlet Bell Radius
- N Number of Vanes



Note: This figure is for reporting and is not used in a proportionality review.

Figure A.35 — Jet Fan

- A Nozzle inlet area after blade discharge
- B Nozzle height
- C Nozzle discharge area
- D Windband inlet area
- E Windband height
- F Windband discharge area
- G Overlap between nozzle and windband

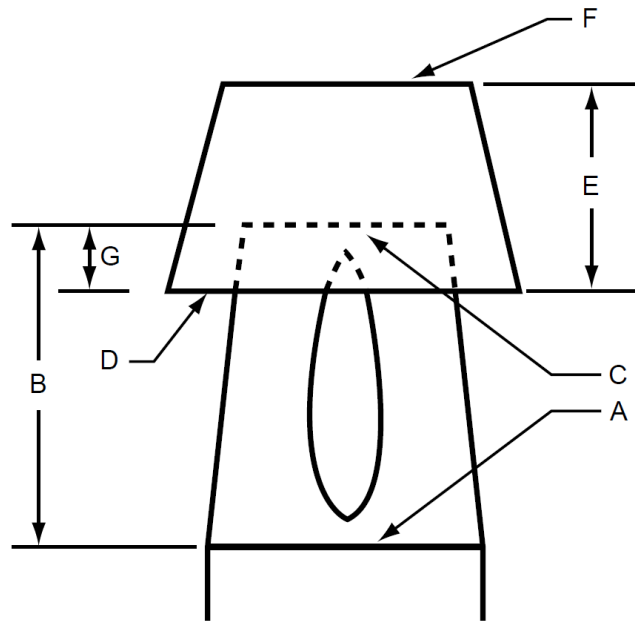

Figure A.36 — Induced Flow Fan Nozzle and Windband

- A Impeller Diameter
- H Hub Diameter
- G Blade Width at Tip
- α Pitch Angle at Tip or at a Designated Radius
- N Number of Blades

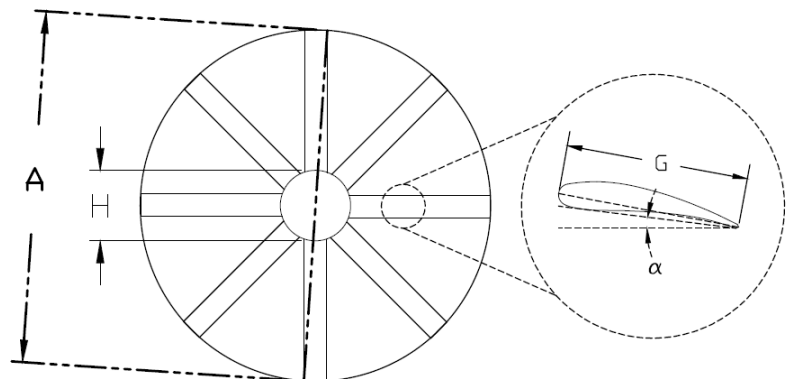

Figure A.37 Ceiling Fans

- D Impeller Diameter
- CL Cylinder Length
- Tip Tip Clearance
(see Figure A.8)
- G Geometry of Inlet
Shape
- T Position of Trailing
Edge of Impeller to
the Outlet Edge
- DD Driver Distance

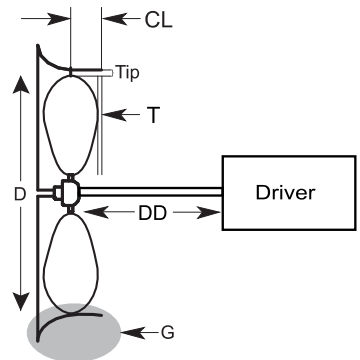
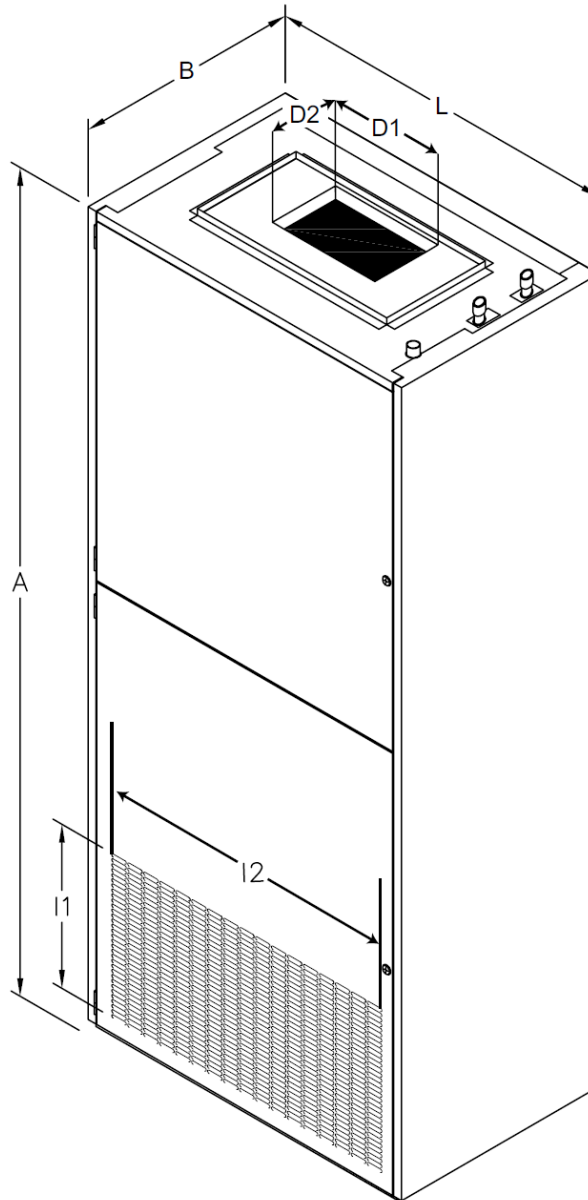

Figure A.38 Axial Impeller

- A Height
- B Depth
- L Width
- D1 Discharge opening width
- D2 Discharge opening length
- I1 Inlet length
- I2 Inlet width



**Figure A.39
Single Room Air Handler**

Annex B

CRP Forms (Informative)

Please contact certification@amca.org for forms. A link to view the various forms used to apply for certification can be found using the following links:

Form	Link
CRP-8	https://amcaconnectstorage.blob.core.windows.net/prod-public/CRP/Templates/CRP_8_Template.xlsx
CRP-A, -B, -L, -M	https://amcaconnectstorage.blob.core.windows.net/prod-public/CRP/Templates/CRP_A_L_M_AS_AI_Template.xlsx

Annex C

Electronic Catalogs (Normative)

C.1 Introduction

This annex covers the special requirements for the use and licensing of electronic catalogs with respect to the AMCA Certified Ratings Program for air performance (AMCA Publication 211) and sound (AMCA Publication 311).

Any computer program, website, set of instructions, screen display or computer-generated printout that provides air performance or sound data for a product line shall be designated an “electronic catalog.” Two main variants of an electronic catalog are “electronic print” and interactive “product selector” software or services.

The electronic print variant of the electronic catalog is primarily subject to the requirements of the main body of this document. An electronic catalog is considered to be this type of variant even if it is not an exact replica of an existing certified print catalog as long as the intent is to show AMCA certified performance information. Examples of electronic print are PDF files that display/print images of print catalogs. Non-interactive website displays of data are considered electronic prints.

This annex focuses on the product selector variant. Such selectors can include software distributed and/or presented on an interactive website. A fundamental characteristic of a product selector is that the end user can configure various fan design and performance criteria that the selector uses to present suitable product design and performance information.

C.2 Scope

An electronic catalog can be used to publish performance data for all products certified with an AMCA Certified Ratings Program seal for air performance or sound and air performance in accordance with this document and 311 requirements.

All requirements outlined in this publication and AMCA Publication 311, including those in this annex, must be met when certifying performance in an electronic catalog.

C.3 Allowable performance modifications

C.3.1 Density correction

Air performance and sound data may continue to be certified to use the AMCA Certified Ratings Program seal where the density is different from standard air because of temperature, elevation, humidity, molecular weight or a combination of these factors.

Correction for known densities other than standard air are allowable, providing that the density effects are calculated as published in AMCA Publication 200, Section 5.

Corrections for elevations and temperatures other than standard air are allowable, providing that the air density correction factors used agree with those published in Annex E of AMCA Publication 200.

C.3.2 Expanded performance data

Electronic catalogs may display performance data that is not present in printed catalogs. The crosshatched areas in Figure C.1 show some of the areas of performance data that may be included in an electronic catalog but excluded in a print catalog.

Air performance and sound data in the crosshatched areas may be certified, provided that this data can be calculated from the fan test data by use of the fan laws or other methods in the product ratings section of this document.

C.3.3 Ratings factors and interpolated ratings

Ratings factors and interpolation among test fans allowed in this publication and 311 may be applied to air and/or sound performance to account for appurtenances. The appropriate primary and secondary statement shall be selected (see Section C.4.1 and C.4.2), depending on the certification status of the ratings factor or interpolated ratings.

C.4 Required qualifying statements

Manufacturers often combine computerized selection with electronic cataloging of air performance and sound data. This data may be corrected for the effect of appurtenances and installation conditions not included in the certified ratings. While these modifications may not be certified, they are quite often provided by manufacturers to assist the user in applying the performance information correctly.

Qualifying statements shall be displayed with the air and/or sound performance ratings to assist the user in applying this information correctly. The qualifying statements may be divided into primary and secondary statements.

When presenting products and/or sizes certified at different levels, a clear differentiation must be made between the products and/or sizes presented that are not certified and those that are certified. Products that are certified shall clearly identify their certification level.

C.4.1 Primary statements

Primary statements must appear on the same screen as the selections.

C.4.1.1 Certified air performance with appurtenances

When air performance is certified and corrections and appurtenances applied to the fan duplicate the test conditions, use the following statement:

“The AMCA Certified Ratings Program seal applies for air performance.”

If the license is extended to certifications of FEI, CFEI, FEG or combinations thereof, use this statement:

“The AMCA Certified Ratings Program seal applies for air performance and [add as appropriate: FEI, CFEI, FEG].”

C.4.1.2 Certified air and sound performance with appurtenances

When air and sound performance are certified and corrections and/or appurtenances applied to the fan duplicate the test conditions, use the following statement:

“The AMCA Certified Ratings Program seal applies for sound and air performance.”

If the license is extended to certification of FEI, CFEI, FEG or combinations thereof, use this statement:

“The AMCA Certified Ratings Program seal applies for sound and air performance and [add as appropriate: FEI, CFEI, FEG]

C.4.1.3 Certified air performance and noncertified modifications for the effect of appurtenances

When air performance is certified but noncertified modifications for the effect of appurtenances are applied to the fan ratings, use the following statement:

“The AMCA certified ratings seal applies for air performance without the effect of appurtenances.”

If the license is extended to certification of FEI, CFEI, FEG or combinations thereof, use this statement:

“The AMCA Certified Ratings Program seal applies for air performance and [add as appropriate: FEI, CFEI, FEG] without the effect of appurtenances.”

C.4.1.4 Certified air and sound performance and noncertified modifications for the effect of appurtenances

When air and sound performance are certified but noncertified modifications for the effect of appurtenances are applied to the fan ratings, use the following statement:

“The AMCA Certified Ratings Program seal applies for sound and air performance without the effect of appurtenances.”

If the license is extended to certification of FEI, CFEI, FEG or combinations thereof, use this statement:

“The AMCA Certified Ratings Program seal applies for sound and air performance and [add as appropriate: FEI, CFEI, FEG] without the effect of appurtenances.”

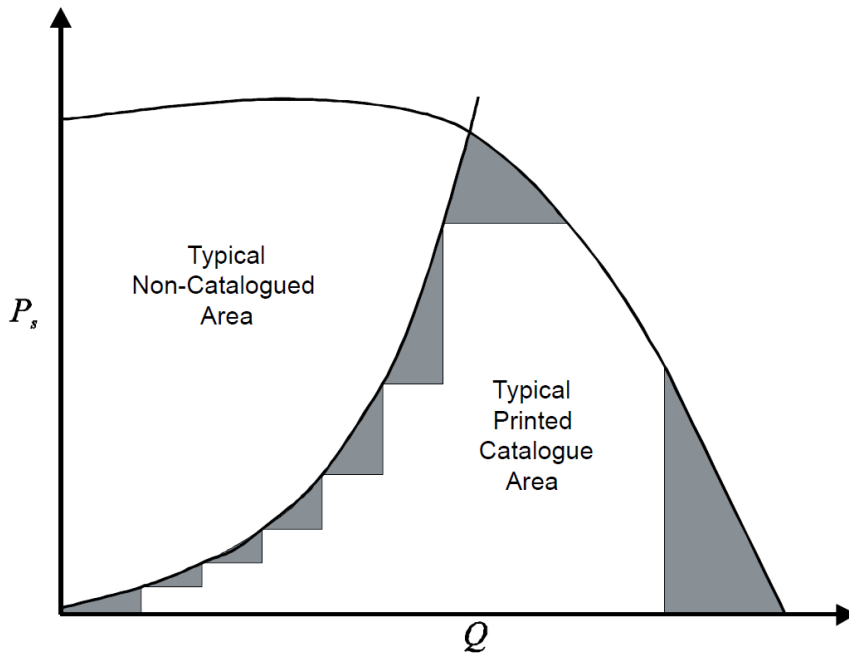

Figure C.1 — Expanded Performance Data

C.4.1.5 Power statements

In addition to the above, primary statements must include the appropriate power statement from Section 9 for the rating method used. This shall be incorporated by adding the following to the end of the primary statement:

“Power includes (or excludes) transmission losses.”

C.4.1.6 Fans FEI certified

Additional requirements (related to FEI) that must be displayed on the primary screen include the maximum compliant fan speed and the highest FEI at standard air. For non-continuously variable fans (e.g., multiple fixed pitches, centrifugal wheel widths, etc.), the FEI shown shall correspond to the actual performance point, not the requested or interpolated performance point.

C.4.2 Secondary statements

The secondary statements shall contain all other qualifying statements required by this document and AMCA Publication 311. They may be on the primary screen or on an easily accessible secondary screen.

Instructions to access the secondary qualifying statements shall be clearly displayed on the primary screen.

When the product is certified to bear the AMCA Certified Ratings Program seal for fan air and/or sound performance and noncertified modifications have been applied to the ratings, the following additional qualifying statements shall appear on the secondary screen:

“The AMCA Certified Ratings Program seal applies for air and/or sound performance data has been modified for installation, appurtenances, etc. not included in the certified data. The modified performance is not certified per the AMCA Certified Ratings Program but is provided to aid in selection and application of the product.”

C.4.3 Required statements on printouts

All required qualifying statements shall appear on any electronic files created, saved or printed by the electronic catalog. The statements shall be adjacent to or in the same document as referenced certified data. For purposes of this paragraph, a document is defined as a single output file. This document may print on several pages and must be identified with sequential page counts (e.g., page 1 of 3).

C.5 Certification of electronic performance data

The ratings for each certified product in an electronic catalog shall be based on product test data obtained in accordance with appropriate AMCA International test standards.

When an electronic print catalog corresponds to an existing certified print catalog, there are three possible presentations of the certified data: the electronic print is identical to the print, the electronic print is a subset of the print or the electronic print is a superset of the print. The subset and superset cases shall be considered new catalogs.

A printed catalog shall not be required for certification of performance data in an electronic catalog. All electronic catalog representations for certified products that present performance ratings shall be subject to review per the AMCA Certified Ratings Program.

C.5.1 Electronic catalog review

AMCA International staff shall review the proposed air and/or sound performance ratings presented in an electronic catalog to verify that they are in agreement with the appropriate test data. AMCA International staff will advise the applicant if they find any areas in question or disagree with the test data, which then must be corrected before a notice of acceptability can be issued.

When changes to the electronic catalog are made, the manufacturer shall identify them clearly for review. Only these changes need to be reviewed, not the complete product selector or electronic print document. The manufacturer shall provide AMCA International staff with the revised electronic catalog for review. AMCA International staff shall advise the licensee if there are any changes or corrections required to meet the requirements of the AMCA International Certified Ratings Program.

C.6 Version numbers

All electronic catalogs that contain certified data shall include a unique version number and date. The date shall be in the following notation: “January 2016.” Both the version number and date shall be visible on the first screen of the electronic catalog. Any change in the certified data of any product within an electronic catalog shall require that any new version of the electronic catalog must be produced with an identifiable change in the version number. Alternatively, the electronic catalog can contain revision information that lists dates and descriptions of all revisions made therein.

C.7 Identifying certified performance

To identify products that are certified to bear the AMCA Certified Ratings Program seals, electronic catalogs shall provide a product directory that includes all products contained within. The directory shall clearly identify each product as one of the following:

- The AMCA Certified Ratings Program seal for air performance
- The AMCA Certified Ratings Program seal for sound and air performance
- The AMCA Certified Ratings Program seal for cfm/watt

- The AMCA Certified Ratings Program seal for FEI
- The AMCA Certified Ratings Program seal for CFEI
- The AMCA Certified Ratings Program seal for FEG
- Not certified per the AMCA Certified Ratings Program, (or leave blank)

References to certified products shall include the corresponding print and/or electronic print catalog identification references. Instructions for access to this product directory shall be included in an easily identifiable manner.

When both certified and noncertified performance is presented together in the viewable area of a screen or in a document, the certified performance must be identified clearly. This shall include explanatory text adjacent to the performance and may also include visual changes to the presentation of the performance (thickness, color, style, typeface, etc.).

C.8 AMCA International directory listings

Electronic catalogs containing certified data shall be listed in AMCA International's directory of certified products, along with printed catalogs for certified products.

Annex D

Guidelines for Development of Fan Performance Ratings (Informative)

D.1 Introduction

There are a number of factors that affect fan performance ratings when using the fan laws to calculate fan ratings from the test of a single fan at a single speed.

D.2 Similarity

The following guidelines are intended to provide an understanding of the various factors that affect the calculated fan performance.

D.2.1 Geometrically similar products

Fans are geometrically similar if the surfaces of the fan parts in their airflow passages are geometrically similar. This implies that linear dimensions of the fan parts and their relative positions are proportional and the angles defining the position and shape of their surfaces are equal. The conditions of proportionality include thickness of the fan parts completely immersed in the airflow, clearances between impeller and stationary parts and roughness of the surfaces of fan parts exposed to the airflow. Exact geometric similarity among fans is seldom obtained, but small deviations in similarity are acceptable if they produce performance deviations substantially smaller than the allowable performance tolerance.

Fans covered in this program should be considered similar even if the proportions of impeller hubs (it does not apply to the boss of the impellers of axial fans), fan shafts, fan bearing housings, motors and drives that are in the flow passage vary but result in net flow areas within 7.5% of that derived from proportionality. The effects of bolts, nuts, rivets, etc., should be considered negligible.

The thickness of the fan parts (e.g., single thickness blades and vanes, thin braces, etc.) immersed in the airflow should be considered geometrically similar even if they depart slightly from exact proportionality. If the thickness and/or roughness of such parts depart significantly from proportionality, the parts should not be considered geometrically similar unless the fan manufacturer demonstrates through comparison testing that these deviations from similarity produce performance deviations substantially smaller than the allowable performance tolerance.

D.2.2 Kinematic similarity

Complete kinematic similarity between two fans requires that the velocity vectors at corresponding points in the gas stream be proportional in magnitude and equal in direction. This implies geometric similarity, similar flow surface boundary layers and similar gas density variations. Geometrically similar fans are considered kinematically similar provided that the gas density variations are negligible. This assumption is generally true when the absolute fan pressure ratio does not exceed 1.025 (fan pressure rise of 2.5 kPa [10 in. wg]).

D.2.3 Dynamic similarity

Complete dynamic similarity between two fans requires that all forces at corresponding points in their flow fields are proportional. This implies Reynolds number and Mach number equality between the test fan and the rated fan. It is rarely possible to achieve both Reynolds number and Mach number equality between two fans. For fans, it is generally possible to ignore Mach number effects. Variations in Reynolds numbers can be important and should not be ignored in all cases.

Excluding the effects of the Reynolds number, fans can be considered kinematically and dynamically similar when they are geometrically similar.

D.3 Compressibility

The general fan laws defined in ANSI/AMCA Standard 99 include the effects of compressibility. For incompressible flow, the (K_p/K_{pc}) term is taken as 1. Some effects of compressibility exist in all fan performance, but the effects are small for fan total pressures up to 2.5 kPa (10 in. wg) and, therefore, are generally ignored for fan performance below this pressure.

The fan manufacturer may use either the compressible or incompressible fan laws for conversion of test data to other speeds and sizes; however, it is recommended that the compressible fan laws be used to calculate fan performance ratings at static pressures above 2.5 kPa (10 in. wg). In this case, stating the reference barometric pressure is useful.

D.4 Test fan sizes and test speeds

Fan laws are derived assuming that fan performance is independent of the Reynolds number. However, it has been established that fan performance is not independent of the Reynolds number, and, therefore, the effect of Reynolds numbers should be considered in developing fan performance ratings.

Fan Reynolds number, Re , is defined as:

$$Re = \frac{\pi \rho N D^2}{C_R \mu}$$

Where:

		SI	I-P
N	Speed	Rev/sec	rpm
C_R	Constant	1	60
D	Diameter	m	ft
ρ	Density	kg/m ³	lbm/ft ³
μ	Absolute viscosity	N•s/m ²	lbm/ft•s

Fan Reynolds number, Re , at standard air density:

$$Re = 0.2073 \times 10^6 \times ND^2 \quad (\text{SI})$$

or

$$321.4 \times ND^2 \quad (\text{I-P})$$

When calculating to speeds lower than the test fan speed or to larger sizes at speeds resulting in Reynolds numbers lower than the test fan, the effect of the Reynolds number may become significant and should be evaluated by the fan manufacturer. It is recommended that the test fan be tested at the lowest speed cataloged.

Fan Reynolds number effects in general vary with the type of fan, appurtenances and point of operation. The effect of the fan Reynolds number on performance decreases with increasing fan Reynolds numbers, and, for every family of geometrically similar units, it is possible to define a threshold fan Reynolds number above which the fan performance is essentially independent of the Reynolds number.

Experimental data has found that the threshold fan Reynolds numbers for various types of fans are approximately as follows:

Fan Type	Reynolds Number
Airfoil centrifugal and axial fans	2×10^6
Backward-inclined, flat-bladed centrifugal fans	1×10^6
Forward-curved centrifugal fans	0.8×10^6
Radial-bladed centrifugal fans	0.4×10^6
Propeller fans	0.8×10^6

The effect of the fan Reynolds number generally can be disregarded under the following conditions:

- When the test fan is tested above the threshold Reynolds number and all calculated performance ratings are at or above the threshold Reynolds number.
- When test fan results are rated to other speeds that result in Reynolds numbers equal to 0.67 of the test Reynolds number or greater or are rated to larger sizes that result in Reynolds numbers equal to 0.67 of the test fan Reynolds number or greater.

When calculating to speeds lower than the test fan speed or to larger sizes at speeds resulting in Reynolds numbers lower than the test fan Reynold's number, the effect of Reynolds numbers may become significant and should be evaluated by the fan manufacturer. It is recommended that the test fan be tested at several speeds higher than the range that will be cataloged, including one test within 5% of the lowest cataloged speed. From these tests, the effect of the fan Reynolds number can be evaluated to determine correction for the fan Reynolds number and should be included in the fan's performance rating. The effects of the fan Reynolds number on calculated fan performance can be minimized by careful selection of the test fan speed; these effects also may be accounted for by developing fan Reynolds number factors to be applied to the calculated performance.

Because larger fans tend to perform better than smaller geometrically similar fans, it is advisable to test a number of fan sizes from the geometrically similar series. If not all sizes in the series have been tested, then the performance rating of a larger fan can be developed from the test of a smaller fan, i.e., using fan laws.

If a fan series has one or more fans that are not geometrically similar, then all non-geometrically similar fans should be tested for rating.

If the highest blade tip speed within the rated performance range of the fan is equal to or lower than 152 m/s (30,000 fpm), then the fan should be tested at multiple speeds within the range or at least should be tested at one speed not higher by more than 5% from the lowest rated speed in the range. The performance for other speeds within the rated performance range should be developed from the closest lower-tested speed by using fan laws if only one test speed is used. If more than one test speed is used, fan laws or an interpolation method should be used.

If the lowest blade tip speed within the rated performance range of the fan is higher than 152 m/s (30,000 fpm), then the fan should be tested at multiple speeds within the range, or at least should be tested at one speed not less than 5% from the highest-rated speed in the range. The performance for other speeds within the rated performance range should be calculated from the closest higher-tested speed by using fan laws if only one test speed is used. If more than one test speed is used, fan laws or an interpolation method should be used.

If the highest blade tip speed within the rated performance range of the fan is higher than 152 m/s (30,000 fpm) and the lowest blade tip speed is lower than 152 m/s (30,000 fpm), the performance range should be divided in two subranges by the speed at which the blade tip speed is equal to 152 m/s (30,000 fpm). In each subrange, the rules from the previous two paragraphs should be applied accordingly.

D.5 Power transmission losses

For fans that are cataloged with power ratings that include drive loss (bearing drag losses, V-belt drag losses, coupling losses, losses caused by the addition of accessories, such as shaft seals, etc.), the power loss of both the bearings and drive elements may be accounted for separately when calculating the test fan rating to other speeds or sizes. The power loss of the drive and bearings of the test fan shall be determined by test, which then can be subtracted from the measured test fan power, including the drive loss to obtain the fan power to be used to calculate the test fan data to other speeds or sizes. The actual bearing and drive loss at the calculated speed and size then must be added to the calculated fan power to obtain the cataloged fan power rating. It is the responsibility of the fan manufacturer to establish the actual bearing and drive loss power at calculated conditions by test or from data obtained from the bearing and drive manufacturer. Where input powers are specified, it is necessary to account for motor losses.

Fans, other than those where the impeller is mounted on the prime mover shaft, are equipped with bearings and, in some cases, couplings. The power consumed by these components is included in the fan power rating.

Because the power consumed by the bearings does not change with speed and size in the same similarity relationship as the fan laws, it is permissible to subtract the bearing loss from the power measurement of the test fan before calculating the fan performance to other speeds or sizes, then adding back the actual bearing loss for the calculated speed or size. The test fan's bearing loss can be determined via test. It is the fan manufacturer's responsibility to establish the actual bearing loss power at calculated conditions via test or data obtained from the bearing manufacturer.

Annex E

Reference Material (Informative)

1. AMCA Publication 802, *Industrial Process/Power Generation Fans: Establishing Performance Using Laboratory Models*, Air Movement and Control Association International Inc., Arlington Heights, IL USA.
2. Howitt, I. "Geometric Similarity." AMCA Paper 1065, Air Movement and Control Association International Inc., Arlington Heights, IL USA, 1979.
3. Clarke, M.S. "Dynamic Similarity." AMCA Paper 1066, Air Movement and Control Association International Inc., Arlington Heights, IL USA, 1979.
4. Bohanon, H.R. "Dimensionless Coefficients." AMCA Paper 1030, Air Movement and Control Association International Inc., Arlington Heights, IL USA, 1977.
5. Phelan, J.J., Russell, S.H., and Zeluff, W.C. "A Study of the Influence of Reynolds Numbers on the Performance of Centrifugal Fans." ASME Paper 78-WP/PTC-1. New York: ASME, 1978.
6. AMCA Publication 11, *Certified Ratings Program Operating Manual*, Air Movement and Control Association International Inc., Arlington Heights, IL USA.

Annex F

Summary of Available Ratings Methods (Informative)

	A	B	C	D	E	F
Speed	Constant	Constant	As-run	Constant	As-run	As-run
Mechanical Drive Type	Belt or direct	Belt	Belt	Direct	Direct	Direct
Includes Drive Mechanical Losses	No	Yes	Yes	N/A	N/A	N/A
Input Power	Fan	Fan	Fan	Fan or power drive system (PDS) ¹	Fan or PDS ¹	Volts and hertz fan/motor when greater than 500 W
Integral Shaft or Bearing	Yes	Yes	Yes	No	No	No
Motor Slip	N/A	N/A	Low	Low	Low	High
Can Use Fan Laws for Speed and Size Changes	Yes	Yes	Yes	See note 2	See note 2	No

Notes:

1. Agricultural ventilation fans catalog cfm/W, see Section 17.
2. Calculation to other speeds requires measurement of fan input power.

Annex G

Labeling Requirements for Fans with a Regulated Motor and/or Certified FEI (Normative)

G.1 Scope

All products with FEI certification that are regulated by an Authority Having Jurisdiction (AHJ) shall meet the labelling requirements of this annex.

The AHJ may have specific labeling requirements that are different than the requirements in Section G.2; AHJ requirements shall supersede the requirements in that section.

Fans with certified FEI are not required to have their FEI value or any related information on their label. If an FEI value is shown on the label, all information in Section G.2 shall be included.

G.2 Information required

When an FEI value is listed on the label, the following information shall be shown:

- Manufacturer
- Model number (as found in the AMCA International directory of certified products)
- Date manufactured or serial number traceable to the date of manufacture
- If the application duty point is known:
 - Airflow
 - Fan pressure (static or total as applicable)
 - Density (if other than standard density)
 - FEI
 - Impeller rotational speed.
- If the application duty point is not known:
 - Highest FEI at maximum speed and standard density
 - Whether static or total pressure was used to calculate FEI
 - Corresponding impeller rotational speed
 - The statement, “FEI shown is maximum FEI at maximum allowable fan speed”
- Internet link that provides public access to a performance map(s) that includes fan pressure, airflow and FEI (QR code, URL or equivalent). This requirement does not apply to ceiling fans, circulator fans or large diameter ceiling fans
- If motor is known:
 - The motor description: type of motor, output power, nameplate speed.
- If the motor is not known:
 - The default motor efficiency as determined in Section 5.3.4 of ANSI/AMCA Standard 208
 - The statement, “FEI is based on the default motor efficiency calculation.”
- If the fan includes a control:
 - The control description (e.g., VFD brand/model)
- AHJ, if known and applicable
- Fan category, according to ANSI/AMCA Standard 208
- Installation type
- Exempt statement, if applicable

G.3 Performance map requirements

The required performance map will display the fan’s aerodynamic pressure curve (or table of values) (i.e., static or total pressure vs. airflow) in relationship to its speed and FEI at each achievable duty point. For fans that have a variable pitch impeller changeable by the customer, the map shall include the performance over the adjustable range. Other factors, such as solidity, can be included. Examples are shown in figures G.3a and G.3b.

In many cases, the performance map can be directly obtained from a publicly accessible print catalog or electronic fan selection software. An internet link may point to an individual performance map, an entire catalog or the electronic fan selection software.

G.4 Label's physical requirements

A label shall be placed in such a position on the fan that it is accessible and readable when the fan is installed as intended.

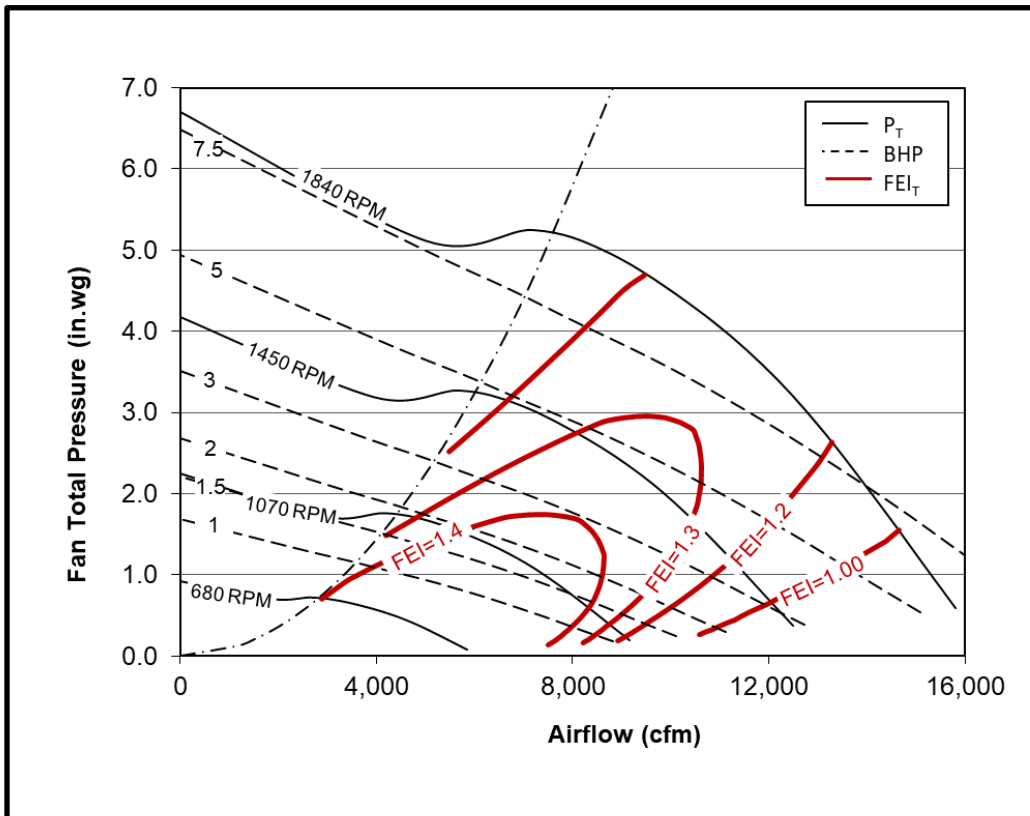

Figure G.3 a. – Performance Map Example

Q (cfm)	P _T (in. wg)	N (rpm)	W _c (W)	FEI
2253	1.14	1229	811	1.13
2118	1.36	1307	807	1.21
1944	1.65	1409	801	1.31
1766	1.94	1522	800	1.36
1587	2.24	1636	800	1.40
1411	2.53	1771	790	1.42
1234	2.56	1808	721	1.42

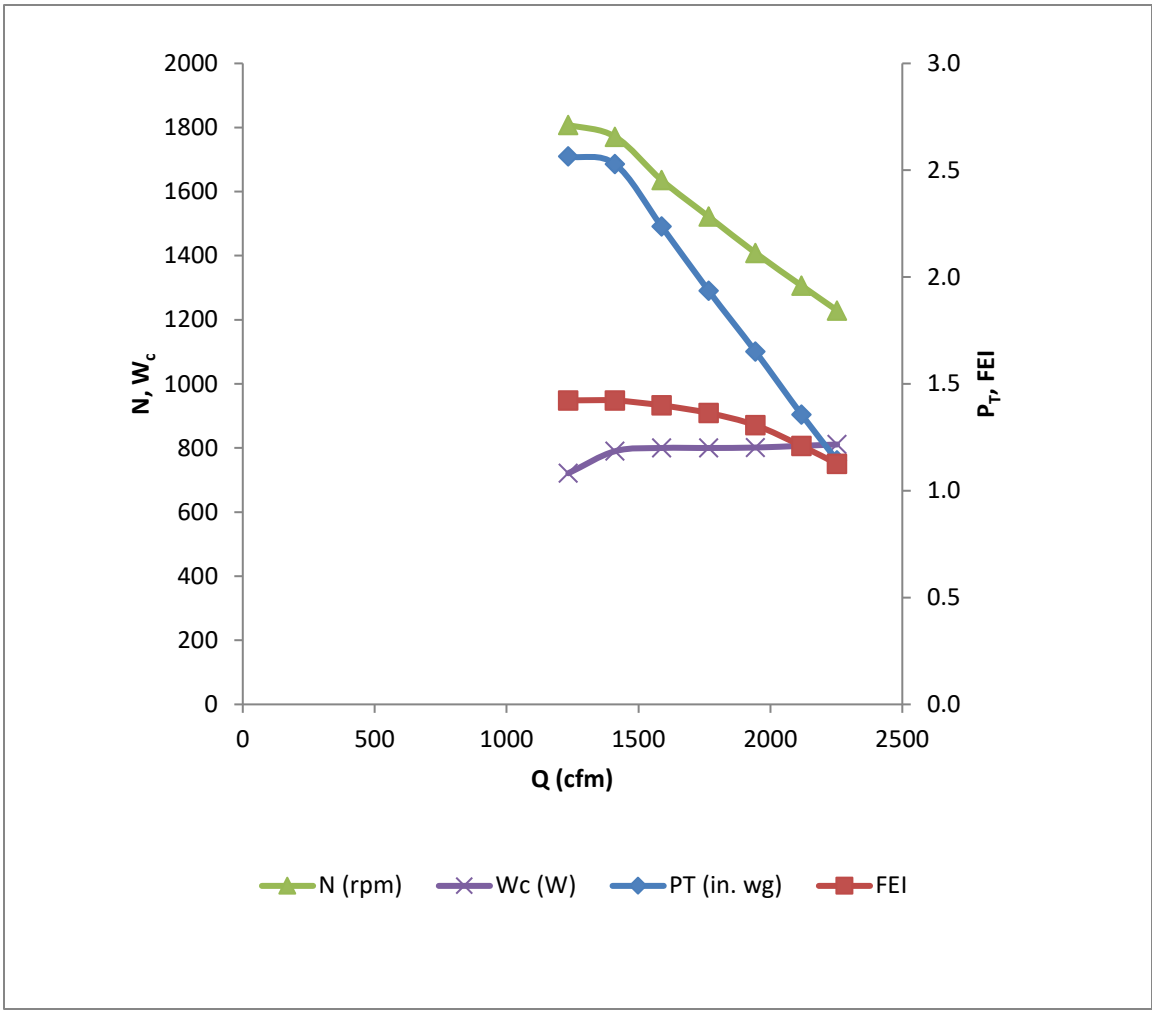

Figure G.3 b. – Performance Map Example

Annex H

Fan Electrical Input Power with Unregulated Motors and Controllers (Normative)

H.1 General

This annex covers ratings of fan electrical power based on separate tests of shaft-to-air fan input power and a wire-to-shaft PDS, which includes a motor and motor controller. The PDS could include an AC induction, electrically commutated or permanent magnet motor and either a separate or integral VFD or other motor controller.

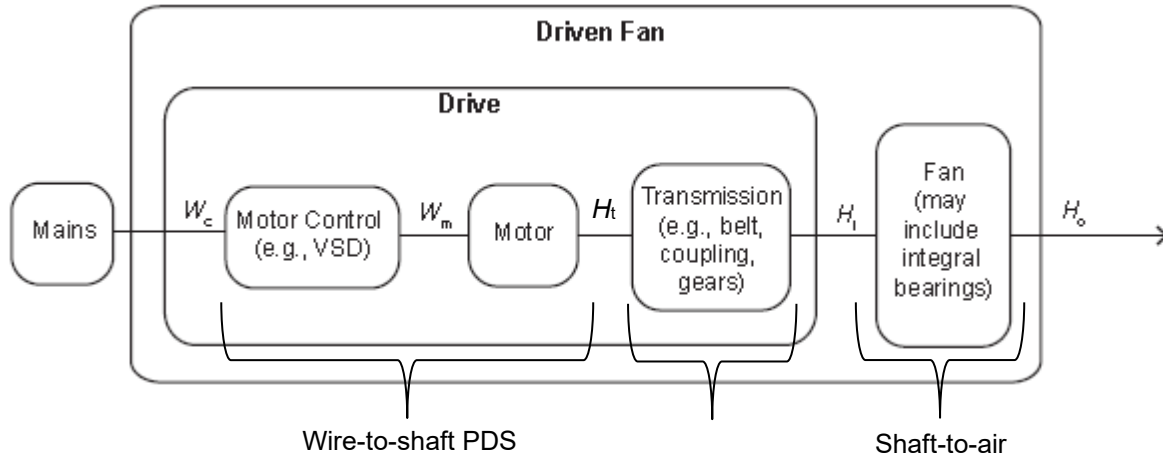

Figure H.1 – Fan Power Map

To combine separate fan and drive component tests to determine fan electrical power, the fan input power, H_i , is divided by the drive component efficiencies as shown in Figure H-1 corresponding to the required fan speed and shaft power. Note that these are not nameplate or nominal efficiencies; they are efficiencies corresponding to the required speed and load (in this document, the term “load” is used to refer to either power or torque).

V-belt or other transmission efficiency, if not tested with the fan, shall be calculated in accordance with ANSI/AMCA Standard 207 and used to determine motor output power:

$$H_t = H_i \left(\frac{1}{\eta_{\text{transmission}}} \right) \quad \text{Eq. H.1}$$

Fan electrical input power then is calculated using either direct lookup from a table containing tested input power or tested efficiency of the PDS:

$$W_c = H_t \left(\frac{1}{\eta_{\text{motor+control}}} \right) \quad \text{SI} \quad \text{Eq. H.2}$$

$$W_c = H_t \left(\frac{1}{\eta_{\text{motor+control}}} \right) \times 0.7457 \quad \text{I-P} \quad \text{Eq. H.2}$$

In some cases, the PDS and transmission can be treated as a single unit, referenced in Figure H.1 as “Drive.” In such cases, they shall be tested as a single unit, and their respective efficiencies can be combined:

$$W_c = H_i \left(\frac{1}{\eta_{\text{motor+control+transmission}}} \right) \quad \text{SI} \quad \text{Eq. H.3}$$

$$W_c = H_i \left(\frac{1}{\eta_{\text{motor+control+transmission}}} \right) \times 0.7457 \quad \text{I-P} \quad \text{Eq. H.3}$$

H.2 PDS testing

Various motor and motor controller test standards exist, but none for the specific purpose of mapping PDS efficiency at all speeds and load points. Permissible test methods include portions of the following test standards, including their individual scope limits:

-
- ANSI/ASHRAE Standard 222, Standard Method of Test for Electrical Power Drive Systems
- CAN/CSA C838, Energy efficiency test methods for three-phase variable frequency drive systems
- CAN/CSA C747, Energy efficiency test methods for small motors
- IEEE 112-96, Test Procedure for Polyphase Induction Motors and Generators

The test standard selected shall be applicable to the equipment being tested and followed except that a) only the efficiency test of the PDS need be run and b) speed and load points used for drive component testing shall be as defined in Section H.6.

H.3 Lab requirements and instrumentation

One of the test standards in Section H.2 shall be used in an AMCA Publication 111 or ISO/IEC 17025 laboratory accreditation program to determine the PDS efficiency.

H.4 Test conditions

Motors and controllers shall be tested at the name plate voltage over the range of speeds and loads in which the fans are to be rated (see Section H.6). Test conditions and equipment must be as specified in the test standard used. The temperature and operation of the motor(s) and controller(s) shall be stable for each tested operating point. If the PDS includes a motor controller, the input power is measured at the input to the controller.

H.5 Test report

The test report shall include:

- Description of equipment tested, including manufacturer and model number.
- Nameplate voltage, frequency and power.
- Controller parameters used for the test include mode (variable or constant torque), carrier frequency, maximum frequency, maximum output voltage, V/f ratio and output algorithm.
- Environmental conditions, such as barometric pressure, temperature and humidity, during the test.
- Measurements and calculated data resulting in a map of PDS input power (kW) vs. speed and load.
- Additionally, the map may include PDS efficiency for each tested point.

H.6 Speed and load points

Speed and load determination points must cover the entire range to be rated. Determination points need not be restricted by motor nameplate ratings in speed or load; however, test data cannot be extrapolated beyond these measured points. Intermediate data between tested points shall be based on a simple linear interpolation or a polynomial curve fit. In no case shall the curve fit result in efficiencies exceeding the nearest test values. If efficiency vs. load is within 5% of the average of all test speeds, the average efficiency vs. load can be used for the entire speed range.

For example, if the efficiency vs. load data includes values, 91.5, 90, 88, 87 and 86, the average would be 88.5. A 5% range would include any values between 92.9 and 84.1, so this example would be allowed to use 88.5 for the entire range.

Table H.1 — Determination points examples

		Speed (Percent Rated)				
		25%	50%	75%	100%	125%
Torque (Percent Rated)	125%				X	
	100%			X	X	X
	75%		X	X	X	X
	50%	X	X	X	X	X
	25%	X	X	X	X	X

Table H.2 — PDS test result examples

		Speed (Percent Rated)				
		25%	50%	75%	100%	125%
Torque (Percent Rated)	125%				88%	
	100%			91%	90%	88%
	75%		86%	89%	88%	86%
	50%	79%	83%	85%	85%	83%
	25%	70%	79%	81%	81%	79%

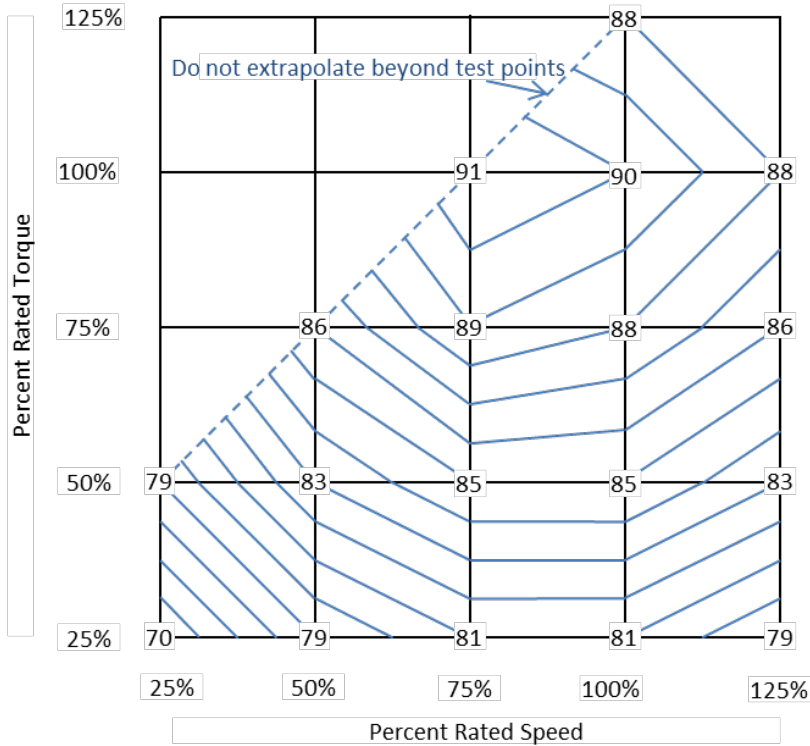

Figure H.2 – Interpolation example (efficiency vs. torque and speed)

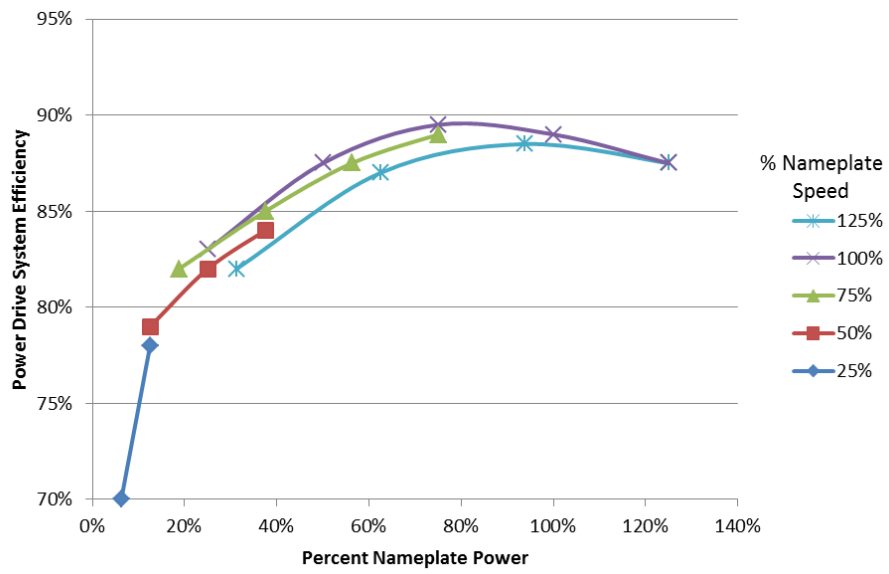

Figure H.3 –Curve fit example (efficiency vs. power and speed)

Annex I

Calculation Methods for Determining Fan Performance Ratings (Normative)

Fan performance testing is the backbone of the AMCA Certified Ratings Program. Calculations are needed to convert tested fan performance data to published performance ratings. This annex provides requirements for the use of calculation methods to develop fan performance ratings for the AMCA Certified Ratings Program.

I.1 Scope

The fan affinity laws (commonly known as fan laws) are documented in AMCA Standard 99. The fan laws are detailed in Section I.4 and are used to convert performance of a single tested fan size and speed to a single non-tested size and speed. Section I.5 builds on the fan laws by adding interpolation techniques to convert performance from multiple tested fan speeds to an intermediate speed. This section can be used for either wire-to-air tests or shaft-to-air tests. Section I.6 provides a similar interpolation technique to convert performance from multiple tested fan sizes to an intermediate fan size. Section I.7 includes techniques used for interpolation based on dimensional variables other than fan speed or diameter.

Conversion formulae in this annex include changes in density and effects of compressibility. Often these effects are not needed when developing catalog ratings. When appropriate, simplified equations are shown without these factors and are identified with an “a” or “b” after the equation number.

Use of the fan laws or interpolated fan laws as found in Sections I.4, I.5, and I.6 require strict geometric similarity. See Annex D for details.

I.2 Symbols and subscripts

The following symbols and subscripts are used in this annex:

Symbol	Description	SI Unit	I-P Unit
D	Impeller diameter	m	ft
H	Fan shaft input power	W	hp
K_p	Compressibility coefficient	dimensionless	
N	Impeller rotational speed	rpm	rpm
P	Fan pressure (either static or total)	Pa	in. wg
P_s	Fan static pressure	Pa	in. wg
P_t	Fan total pressure	Pa	in. wg
Q	Fan airflow	m ³ /s	cfm
W	Fan electrical input power	W	W
X	Geometric feature used for interpolation	any consistent unit	
x	Function used to determine K_p	dimensionless	
z	Function used to determine K_p	dimensionless	
η	Fan efficiency (either total or static)	dimensionless	
η_e	Overall fan system efficiency (either total or static)	dimensionless	
ρ	Fan air density	kg/m ³	lbm/ft ³
γ	Ratio of specific heats	dimensionless	

Subscript	Description
c	Converted or calculated value
1	Value at lower speed or smaller diameter
2	Value at higher speed or larger diameter
c1	Intermediate value estimated from lower speed or smaller diameter
c2	Intermediate value estimated from higher speed or larger diameter
std	Standard density conditions

I.3 Compressibility

The general fan laws and interpolation methods defined in this annex include the effects of compressibility. For incompressible flow, the compressibility coefficient, K_p , is taken as 1. Some effects of compressibility exist in all fan performance, but the effects are small for fan total pressures up to 2.5 kPa (10 in. wg) and, therefore, are generally ignored for fan performance below this pressure.

The fan manufacturer may use either the compressible or incompressible conversion formulae to calculate ratings for other speeds and sizes; however, it is recommended that the compressible equations be used to calculate fan performance ratings at static pressures above 2.5 kPa (10 in. wg).

The following equations for compressibility coefficients shall be used as needed throughout this annex. The ratio of specific heat at constant pressure to the specific heat at constant volume, γ , is equal to 1.4 for air.

$$K_{p1} = \left[\frac{\ln(1+x_1)}{x_1} \right] \cdot \left[\frac{z_1}{\ln(1+z_1)} \right] \quad \text{Eq. I.1}$$

$$x_1 = \left(\frac{P_{t1}}{P_{t1,1} + p_{b1}} \right) \quad \text{Eq. I.2 [SI]}$$

$$x_1 = \left(\frac{P_{t1}}{P_{t1,1} + 13.595 \times p_{b1}} \right) \quad \text{Eq. I.2 [IP]}$$

$$z_1 = \left[\frac{\gamma_1 - 1}{\gamma_1} \right] \cdot \left[\frac{H_1}{Q_1 \cdot (P_{t1,1} + p_{b1})} \right] \quad \text{Eq. I.3 [SI]}$$

$$z_1 = \left[\frac{\gamma_1 - 1}{\gamma_1} \right] \cdot \left[\frac{6343.3 \times H_1}{Q_1 \cdot (P_{t1,1} + 13.595 \times p_{b1})} \right] \quad \text{Eq. I.3 [IP]}$$

$$\frac{z_1}{z_c} = \left[\frac{P_{t1,c} + p_{bc}}{P_{t1,1} + p_{b1}} \right] \cdot \left[\frac{\rho_1}{\rho_c} \right] \cdot \left[\frac{N_1}{N_c} \right]^2 \cdot \left[\frac{D_1}{D_c} \right]^2 \cdot \left(\frac{\gamma_c}{\gamma_c - 1} \right) \cdot \left(\frac{\gamma_1 - 1}{\gamma_1} \right) \quad \text{Eq. I.4 [SI]}$$

$$\frac{z_1}{z_c} = \left[\frac{P_{t1,c} + 13.595 \times p_{bc}}{P_{t1,1} + 13.595 \times p_{b1}} \right] \cdot \left[\frac{\rho_1}{\rho_c} \right] \cdot \left[\frac{N_1}{N_c} \right]^2 \cdot \left[\frac{D_1}{D_c} \right]^2 \cdot \left(\frac{\gamma_c}{\gamma_c - 1} \right) \cdot \left(\frac{\gamma_1 - 1}{\gamma_1} \right) \quad \text{Eq. I.4 [IP]}$$

$$z_c = \frac{z_1}{\left(\frac{z_1}{z_c} \right)} \quad \text{Eq. I.5}$$

$$x_c = e^{\left\{ \ln(1+x_1) \cdot \left[\frac{\ln(1+z_c)}{\ln(1+z_1)} \right] \cdot \left(\frac{\gamma_1 - 1}{\gamma_1} \right) \cdot \left(\frac{\gamma_c}{\gamma_c - 1} \right) \right\}} - 1 \quad \text{Eq. I.6}$$

$$\frac{K_{p1}}{K_{pc}} = \left(\frac{z_1}{z_c} \right) \cdot \left(\frac{x_c}{x_1} \right) \cdot \left(\frac{\gamma_1}{\gamma_1 - 1} \right) \cdot \left(\frac{\gamma_c - 1}{\gamma_c} \right) \quad \text{Eq. I.7}$$

$$K_{pc} = \frac{K_{p1}}{\left(\frac{K_{p1}}{K_{pc}} \right)} \quad \text{Eq. I.8}$$

I.4 Fan laws (extrapolation)

The fan laws are used to extrapolate fan performance ratings from a single test of a given fan size and speed to another size and/or speed.

I.4.1 Requirements for use

The fan laws can be used only for shaft-to-air fan performance ratings.

$$D_c \geq D_1 \quad \text{Eq. I.9}$$

The fan laws can be used only for an increase in fan tip speed. Subsequent calculations to other fan speeds for a given fan diameter are allowed, using either the fan laws of this section or interpolation methods of Section I.5.

$$D_c \cdot N_c \geq D_1 \cdot N_1 \quad \text{Eq. I.10}$$

Note that use of the fan laws for calculations to other fan speeds for a given fan diameter are allowed only from a lower fan test speed:

$$N_c \geq N_1 \quad \text{when } D_c = D_1 \quad \text{Eq. I.11}$$

I.4.2 Airflow

Fan airflow rate:
$$Q_c = Q_1 \cdot \left(\frac{D_c}{D_1}\right)^3 \cdot \left(\frac{N_c}{N_1}\right) \cdot \left(\frac{K_{p1}}{K_{pc}}\right) \quad \text{Eq. I.12}$$

or for incompressible flow
$$Q_c = Q_1 \cdot \left(\frac{D_c}{D_1}\right)^3 \cdot \left(\frac{N_c}{N_1}\right) \quad \text{Eq. I.12a}$$

I.4.3 Pressure

Fan total pressure:
$$P_{tc} = P_{t1} \cdot \left(\frac{D_c}{D_1}\right)^2 \cdot \left(\frac{N_c}{N_1}\right)^2 \cdot \left(\frac{K_{p1}}{K_{pc}}\right) \cdot \left(\frac{\rho_c}{\rho_1}\right) \quad \text{Eq. I.13}$$

or for incompressible flow at a constant density
$$P_{tc} = P_{t1} \cdot \left(\frac{D_c}{D_1}\right)^2 \cdot \left(\frac{N_c}{N_1}\right)^2 \quad \text{Eq. I.13a}$$

Fan velocity pressure:
$$P_{vc} = P_{v1} \cdot \left(\frac{D_c}{D_1}\right)^2 \cdot \left(\frac{N_c}{N_1}\right)^2 \cdot \left(\frac{\rho_c}{\rho_1}\right) \quad \text{Eq. I.14}$$

or for a constant density
$$P_{vc} = P_{v1} \cdot \left(\frac{D_c}{D_1}\right)^2 \cdot \left(\frac{N_c}{N_1}\right)^2 \quad \text{Eq. I.14a}$$

Fan static pressure:
$$P_{sc} = P_{tc} - P_{vc} \quad \text{Eq. I.15}$$

or for incompressible flow at a constant density
$$P_{sc} = P_{s1} \cdot \left(\frac{D_c}{D_1}\right)^2 \cdot \left(\frac{N_c}{N_1}\right)^2 \quad \text{Eq. I.15a}$$

I.4.4 Power

Fan input power:
$$H_c = H_1 \cdot \left(\frac{D_c}{D_1}\right)^5 \cdot \left(\frac{N_c}{N_1}\right)^3 \cdot \left(\frac{K_{p1}}{K_{pc}}\right) \cdot \left(\frac{\rho_c}{\rho_1}\right) \quad \text{Eq. I.16}$$

or for incompressible flow at a constant density
$$H_c = H_1 \cdot \left(\frac{D_c}{D_1}\right)^5 \cdot \left(\frac{N_c}{N_1}\right)^3 \quad \text{Eq. I.16a}$$

I.5 Interpolation based on fan speed

Improved accuracy in predicting fan performance ratings is obtained when multiple speeds are tested throughout the fan operating range. Ratings for intermediate speeds then are calculated by interpolation between tested speeds. This method can be used for shaft-to-air tests. This method also can be used for wire-to-air tests since the motor and motor controller efficiencies are captured for each speed in the wire-to-air tests.

I.5.1 Requirements for use

Fan speed interpolation can be used for either wire-to-air tests (electrical power) or shaft-to-air tests (mechanical or fan shaft power). Fan performance ratings must be available for two tested speeds, N_1 and N_2 , which bracket the calculated speed N_c . For shaft-to-air testing, ratings at N_1 and N_2 alternatively can be obtained using the fan laws of Section I.4 or the diameter interpolation methods of Section I.6.

$$N_1 \leq N_c \leq N_2 \quad \text{Eq. I.17}$$

Fan speed interpolation is valid only between corresponding points on each fan curve as defined by the following relationship. This is sometimes referred to as a constant system resistance curve, where pressure varies with airflow squared. This relationship also defines corresponding points when using the fan laws and is obtained by dividing Eq. I.13 by the square of Eq. I.12 while using a constant diameter.

$$\left(\frac{P_{t1}}{\rho_1 \cdot Q_1^2 \cdot K_{p1}} \right) = \left(\frac{P_{tc}}{\rho_c \cdot Q_c^2 \cdot K_{pc}} \right) = \left(\frac{P_{t2}}{\rho_2 \cdot Q_2^2 \cdot K_{p2}} \right) \quad \text{Eq. I.18}$$

or for incompressible flow at a constant density $\left(\frac{P_{t1}}{Q_1^2} \right) = \left(\frac{P_{tc}}{Q_c^2} \right) = \left(\frac{P_{t2}}{Q_2^2} \right)$ Eq. I.18a

and if using static pressure $\left(\frac{P_{s1}}{Q_1^2} \right) = \left(\frac{P_{sc}}{Q_c^2} \right) = \left(\frac{P_{s2}}{Q_2^2} \right)$ Eq. I.18b

At zero airflow (shutoff): $Q_1 = Q_c = Q_2 = 0$ Eq. I.19

At zero pressure (free air): $P_{s1} = P_{sc} = P_{s2} = 0$ Eq. I.20

Note that the requirements of equations I.18 through I.20 likely will require interpolation along fan curves 1 and/or 2 to prior to making the following calculations. This interpolation is not covered in this annex. A moving cubic polynomial curve fit between the nearest four determinations is suggested.

I.5.2 Airflow

Airflow varies linearly with fan speed:

$$Q_c = Q_1 + \left[\frac{(N_c - N_1)}{(N_2 - N_1)} \right] \cdot (Q_2 - Q_1) \quad \text{Eq. I.21}$$

Note that this equation can be rearranged to provide the fan speed required to achieve a desired airflow Q_c :

$$N_c = N_1 + \left[\frac{(Q_c - Q_1)}{(Q_2 - Q_1)} \right] \cdot (N_2 - N_1) \quad \text{Eq. I.22}$$

I.5.3 Pressure

Fan total pressure varies with airflow according to the corresponding points requirement of Section I.5.1:

$$P_{tc} = P_{t1} \cdot \left(\frac{Q_c}{Q_1} \right)^2 \cdot \left(\frac{\rho_c}{\rho_1} \right) \cdot \left(\frac{K_{pc}}{K_{p1}} \right) \quad \text{Eq. I.23}$$

or for incompressible flow at a constant density $P_{tc} = P_{t1} \cdot \left(\frac{Q_c}{Q_1} \right)^2$ Eq. I.23a

and if using static pressure $P_{sc} = P_{s1} \cdot \left(\frac{Q_c}{Q_1} \right)^2$ Eq. I.23b

At zero airflow (shutoff), an interpolation is made between two fan law estimates of P_c :

Estimate from test at N_1 :
$$P_{tc1} = P_{t1} \cdot \left(\frac{N_c}{N_1}\right)^2 \cdot \left(\frac{\rho_c}{\rho_1}\right) \cdot \left(\frac{K_{pc}}{K_{p1}}\right)$$
 Eq. I.24

or for incompressible flow at a constant density
$$P_{tc1} = P_{t1} \cdot \left(\frac{N_c}{N_1}\right)^2$$
 Eq. I.24a

and if using static pressure
$$P_{sc1} = P_{s1} \cdot \left(\frac{N_c}{N_1}\right)^2$$
 Eq. I.24b

Estimate from test at N_2 :
$$P_{tc2} = P_{t2} \cdot \left(\frac{N_c}{N_2}\right)^2 \cdot \left(\frac{\rho_c}{\rho_2}\right) \cdot \left(\frac{K_{pc}}{K_{p2}}\right)$$
 Eq. I.25

or for incompressible flow at a constant density
$$P_{tc2} = P_{t2} \cdot \left(\frac{N_c}{N_2}\right)^2$$
 Eq. I.25a

and if using static pressure
$$P_{sc2} = P_{s2} \cdot \left(\frac{N_c}{N_2}\right)^2$$
 Eq. I.25b

Interpolate between estimates:
$$P_{tc} = P_{tc1} + \left(\frac{N_c - N_1}{N_2 - N_1}\right) (P_{tc2} - P_{tc1})$$
 Eq. I.26

or for incompressible flow
$$P_{sc} = P_{sc1} + \left(\frac{N_c - N_1}{N_2 - N_1}\right) (P_{sc2} - P_{sc1})$$
 Eq. I.26a

I.5.4 Fan input power

Fan input power varies linearly with air power:

$$H_c = H_1 + \left[\frac{(Q_c \cdot P_{tc} \cdot K_{pc} - Q_1 \cdot P_{t1} \cdot K_{p1})}{(Q_2 \cdot P_{t2} \cdot K_{p2} - Q_1 \cdot P_{t1} \cdot K_{p1})} \right] \cdot (H_2 - H_1)$$
 Eq. I.27

or for incompressible flow at a constant density
$$H_c = H_1 + \left[\frac{(Q_c \cdot P_{tc} - Q_1 \cdot P_{t1})}{(Q_2 \cdot P_{t2} - Q_1 \cdot P_{t1})} \right] \cdot (H_2 - H_1)$$
 Eq. I.27a

and if using static pressure
$$H_c = H_1 + \left[\frac{(Q_c \cdot P_{sc} - Q_1 \cdot P_{s1})}{(Q_2 \cdot P_{s2} - Q_1 \cdot P_{s1})} \right] \cdot (H_2 - H_1)$$
 Eq. I.27b

At zero airflow (shutoff), equations I.18 and I.27 are combined to eliminate the airflow terms:

$$H_c = H_1 + \left[\frac{\left(\frac{P_{tc}^{1.5} \cdot K_{pc}}{\rho_c^{0.5}} - \frac{P_{t1}^{1.5} \cdot K_{p1}}{\rho_1^{0.5}} \right)}{\left(\frac{P_{t2}^{1.5} \cdot K_{p2}}{\rho_2^{0.5}} - \frac{P_{t1}^{1.5} \cdot K_{p1}}{\rho_1^{0.5}} \right)} \right] \cdot (H_2 - H_1)$$
 Eq. I.28

or for incompressible flow at a constant density
$$H_c = H_1 + \left[\frac{(P_{tc}^{1.5} - P_{t1}^{1.5})}{(P_{t2}^{1.5} - P_{t1}^{1.5})} \right] \cdot (H_2 - H_1)$$
 Eq. I.28a

and if using static pressure
$$H_c = H_1 + \left[\frac{(P_{sc}^{1.5} - P_{s1}^{1.5})}{(P_{s2}^{1.5} - P_{s1}^{1.5})} \right] \cdot (H_2 - H_1)$$
 Eq. I.28b

At zero pressure (free air), equations I.18 and I.27 are combined to eliminate the pressure terms:

$$H_c = H_1 + \left[\frac{(\rho_c \cdot Q_c^3 - \rho_1 \cdot Q_1^3)}{(\rho_2 \cdot Q_2^3 - \rho_1 \cdot Q_1^3)} \right] \cdot (H_2 - H_1)$$
 Eq. I.29

or at a constant density
$$H_c = H_1 + \left[\frac{(Q_c^3 - Q_1^3)}{(Q_2^3 - Q_1^3)} \right] \cdot (H_2 - H_1)$$
 Eq. I.29a

I.5.5 Fan electrical power

For fans tested wire-to-air only, fan electrical power varies linearly with air power:

$$W_c = W_1 + \left[\frac{(Q_c \cdot P_{tc} \cdot K_{pc} - Q_1 \cdot P_{t1} \cdot K_{p1})}{(Q_2 \cdot P_{t2} \cdot K_{p2} - Q_1 \cdot P_{t1} \cdot K_{p1})} \right] \cdot (W_2 - W_1) \quad \text{Eq. I.30}$$

or for incompressible flow $W_c = W_1 + \left[\frac{(Q_c \cdot P_{tc} - Q_1 \cdot P_{t1})}{(Q_2 \cdot P_{t2} - Q_1 \cdot P_{t1})} \right] \cdot (W_2 - W_1) \quad \text{Eq. I.30a}$

and if using static pressure $W_c = W_1 + \left[\frac{(Q_c \cdot P_{sc} - Q_1 \cdot P_{s1})}{(Q_2 \cdot P_{s2} - Q_1 \cdot P_{s1})} \right] \cdot (W_2 - W_1) \quad \text{Eq. I.30b}$

At zero airflow (shutoff), equations I.18 and I.30 are combined to eliminate the airflow terms:

$$W_c = W_1 + \left[\frac{\left(\frac{P_{tc}^{1.5} \cdot K_{pc}}{\rho_c^{0.5}} \right) - \left(\frac{P_{t1}^{1.5} \cdot K_{p1}}{\rho_1^{0.5}} \right)}{\left(\frac{P_{t2}^{1.5} \cdot K_{p2}}{\rho_2^{0.5}} \right) - \left(\frac{P_{t1}^{1.5} \cdot K_{p1}}{\rho_1^{0.5}} \right)} \right] \cdot (W_2 - W_1) \quad \text{Eq. I.31}$$

or for incompressible flow at a constant density $W_c = W_1 + \left[\frac{(P_{tc}^{1.5} - P_{t1}^{1.5})}{(P_{t2}^{1.5} - P_{t1}^{1.5})} \right] \cdot (W_2 - W_1) \quad \text{Eq. I.31a}$

and if using static pressure $W_c = W_1 + \left[\frac{(P_{sc}^{1.5} - P_{s1}^{1.5})}{(P_{s2}^{1.5} - P_{s1}^{1.5})} \right] \cdot (W_2 - W_1) \quad \text{Eq. I.31b}$

At zero pressure (free air), equations I.18 and I.30 are combined to eliminate the pressure terms:

$$W_c = W_1 + \left[\frac{(\rho_c \cdot Q_c^3 \cdot K_{pc} - \rho_1 \cdot Q_1^3 \cdot K_{p1})}{(\rho_2 \cdot Q_2^3 \cdot K_{p2} - \rho_1 \cdot Q_1^3 \cdot K_{p1})} \right] \cdot (W_2 - W_1) \quad \text{Eq. I.32}$$

or for incompressible flow at a constant density $W_c = W_1 + \left[\frac{(Q_c^3 - Q_1^3)}{(Q_2^3 - Q_1^3)} \right] \cdot (W_2 - W_1) \quad \text{Eq. I.32a}$

I.6 Interpolation based on fan diameter

Improved accuracy in predicting fan performance ratings is obtained when multiple fan sizes are tested throughout a product line. Ratings for intermediate sizes then are calculated by interpolation between tested sizes. This method can be used only for shaft-to-air tests.

I.6.1 Requirements for use

Fan size interpolation can be used only for shaft-to-air tests (mechanical or fan shaft power).

Fan performance ratings must be available for two tested diameters D_1 and D_2 , which bracket the calculated diameter D_c :

$$D_1 \leq D_c \leq D_2 \quad \text{Eq. I.33}$$

Strict proportionality requirements must be met for all three size fans (D_1 , D_c , D_2).

Performance for each test size and the calculated size must be at a constant tip speed. Subsequent changes in fan speed are allowed – either rating up in speed (Section I.4) or interpolation between speeds (Section I.5).

$$D_c \cdot N_c = D_1 \cdot N_1 = D_2 \cdot N_2 \quad \text{Eq. I.34}$$

Note that this requirement likely will require an adjustment in speed – either rating up in speed (Section I.4) or interpolation between speeds (Section I.5) - prior to making the following calculations.

Fan diameter interpolation is valid only between corresponding points on each fan curve as defined by the following relationship. This relationship defines corresponding points when using the fan laws and is obtained by dividing Eq. I.13 by the square of Eq. I.12.

$$\left(\frac{P_{t1} \cdot D_1^4}{\rho_1 \cdot Q_1^2 \cdot K_{p1}}\right) = \left(\frac{P_{tc} \cdot D_c^4}{\rho_c \cdot Q_c^2 \cdot K_{pc}}\right) = \left(\frac{P_{t2} \cdot D_2^4}{\rho_2 \cdot Q_2^2 \cdot K_{p2}}\right) \quad \text{Eq. I.35}$$

or for incompressible flow at a constant density $\left(\frac{P_{t1} \cdot D_1^4}{Q_1^2}\right) = \left(\frac{P_{tc} \cdot D_c^4}{Q_c^2}\right) = \left(\frac{P_{t2} \cdot D_2^4}{Q_2^2}\right) \quad \text{Eq. I.35a}$

and if using static pressure $\left(\frac{P_{s1} \cdot D_1^4}{Q_1^2}\right) = \left(\frac{P_{sc} \cdot D_c^4}{Q_c^2}\right) = \left(\frac{P_{s2} \cdot D_2^4}{Q_2^2}\right) \quad \text{Eq. I.35b}$

At zero airflow (shutoff): $Q_1 = Q_c = Q_2 = 0 \quad \text{Eq. I.36}$

At zero pressure (free air): $P_{s1} = P_{sc} = P_{s2} = 0 \quad \text{Eq. I.37}$

Note that the requirements of equations I.35 through I.37 likely will require interpolation along fan curves 1 and/or 2 to prior to making the following calculations. This interpolation is not covered in this annex. A moving cubic polynomial curve fit between the nearest four determinations is suggested.

I.6.2 Airflow

Airflow is first estimated from each of the tested sizes, using traditional fan laws, then interpolated between these two estimates:

Estimate from test of D_1 : $Q_{c1} = Q_1 \cdot \left(\frac{D_c}{D_1}\right)^3 \cdot \left(\frac{N_c}{N_1}\right)^1 \cdot \left(\frac{K_{p1}}{K_{pc}}\right)^1 \quad \text{Eq. I.38}$

or for incompressible flow at a constant tip speed and density $Q_{c1} = Q_1 \cdot \left[\frac{D_c}{D_1}\right]^2 \quad \text{Eq. I.38a}$

Estimate from test of D_2 : $Q_{c2} = Q_2 \cdot \left(\frac{D_c}{D_2}\right)^3 \cdot \left(\frac{N_c}{N_2}\right)^1 \cdot \left(\frac{K_{p2}}{K_{pc}}\right)^1 \quad \text{Eq. I.39}$

or for incompressible flow at a constant tip speed and density $Q_{c2} = Q_2 \cdot \left[\frac{D_c}{D_2}\right]^2 \quad \text{Eq. I.39a}$

Interpolate between estimates: $Q_c = Q_{c1} + \left[\frac{(D_c - D_1)}{(D_2 - D_1)}\right] \cdot (Q_{c2} - Q_{c1}) \quad \text{Eq. I.40}$

I.6.3 Pressure

Fan pressure (static or total) is calculated from airflow and the corresponding points requirement of Section I.6.1:

$$P_{tc} = P_{t1} \cdot \left(\frac{Q_c}{Q_1}\right)^2 \cdot \left(\frac{D_1}{D_c}\right)^4 \cdot \left(\frac{\rho_c}{\rho_1}\right)^1 \cdot \left(\frac{K_{pc}}{K_{p1}}\right)^1 \quad \text{Eq. I.41}$$

or for incompressible flow at a constant tip speed and density $P_{tc} = P_{t1} \cdot \left(\frac{Q_c}{Q_1}\right)^2 \cdot \left(\frac{D_1}{D_c}\right)^4 \quad \text{Eq. I.41a}$

and if using static pressure $P_{sc} = P_{s1} \cdot \left(\frac{Q_c}{Q_1}\right)^2 \cdot \left(\frac{D_1}{D_c}\right)^4 \quad \text{Eq. I.41b}$

At zero airflow (shutoff), an interpolation is made between two fan law estimates of P_c :

Estimate from test of D_1 :
$$P_{tc1} = P_{t1} \cdot \left(\frac{N_c}{N_1}\right)^2 \cdot \left(\frac{D_c}{D_1}\right)^2 \cdot \left(\frac{\rho_c}{\rho_1}\right)^1 \cdot \left(\frac{K_{p1}}{K_{pc}}\right)^1 \quad \text{Eq. I.42}$$

or for incompressible flow at a constant tip speed and density $P_{tc1} = P_{t1} \quad \text{Eq. I.42a}$

and if using static pressure $P_{sc1} = P_{s1} \quad \text{Eq. I.42b}$

Estimate from test of D_2 :
$$P_{tc2} = P_{t2} \cdot \left(\frac{N_c}{N_2}\right)^2 \cdot \left(\frac{D_c}{D_2}\right)^2 \cdot \left(\frac{\rho_c}{\rho_2}\right) \cdot \left(\frac{K_{p2}}{K_{pc}}\right) \quad \text{Eq. I.43}$$

or for incompressible flow at a constant tip speed and density $P_{tc2} = P_{t2} \quad \text{Eq. I.43a}$

and if using static pressure $P_{sc2} = P_{s2} \quad \text{Eq. I.43b}$

Interpolate between estimates:
$$P_{tc} = P_{tc1} + \left[\frac{(D_c - D_1)}{(D_2 - D_1)}\right] \cdot (P_{tc2} - P_{tc1}) \quad \text{Eq. I.44}$$

I.6.4 Power

Fan input power varies linearly with fan air power:

$$H_c = H_1 + \left[\frac{(Q_c \cdot P_{tc} \cdot K_{pc} - Q_1 \cdot P_{t1} \cdot K_{p1})}{(Q_2 \cdot P_{t2} \cdot K_{p2} - Q_1 \cdot P_{t1} \cdot K_{p1})}\right] \cdot (H_2 - H_1) \quad \text{Eq. I.45}$$

or for incompressible flow $H_c = H_1 + \left[\frac{(Q_c \cdot P_{tc} - Q_1 \cdot P_{t1})}{(Q_2 \cdot P_{t2} - Q_1 \cdot P_{t1})}\right] \cdot (H_2 - H_1) \quad \text{Eq. I.45a}$

and if using static pressure $H_c = H_1 + \left[\frac{(Q_c \cdot P_{sc} - Q_1 \cdot P_{s1})}{(Q_2 \cdot P_{s2} - Q_1 \cdot P_{s1})}\right] \cdot (H_2 - H_1) \quad \text{Eq. I.45b}$

At zero airflow (shutoff):
$$H_c = H_{c1} + \left[\frac{\left(\frac{P_{tc}^{1.5} \cdot K_{pc}}{\rho_c^{0.5} \cdot D_c^2}\right) - \left(\frac{P_{t1}^{1.5} \cdot K_{p1}}{\rho_1^{0.5} \cdot D_1^2}\right)}{\left(\frac{P_{t2}^{1.5} \cdot K_{p2}}{\rho_2^{0.5} \cdot D_2^2}\right) - \left(\frac{P_{t1}^{1.5} \cdot K_{p1}}{\rho_1^{0.5} \cdot D_1^2}\right)}\right] \cdot (H_2 - H_1) \quad \text{Eq. I.46}$$

or for incompressible flow at a constant density $H_c = H_{c1} + \left[\frac{\left(\frac{P_{tc}^{1.5}}{D_c^2}\right) - \left(\frac{P_{t1}^{1.5}}{D_1^2}\right)}{\left(\frac{P_{t2}^{1.5}}{D_2^2}\right) - \left(\frac{P_{t1}^{1.5}}{D_1^2}\right)}\right] \cdot (H_2 - H_1) \quad \text{Eq. I.46a}$

and if using static pressure, $H_c = H_{c1} + \left[\frac{\left(\frac{P_{sc}^{1.5}}{D_c^2}\right) - \left(\frac{P_{s1}^{1.5}}{D_1^2}\right)}{\left(\frac{P_{s2}^{1.5}}{D_2^2}\right) - \left(\frac{P_{s1}^{1.5}}{D_1^2}\right)}\right] \cdot (H_2 - H_1) \quad \text{Eq. I.46b}$

At zero pressure (free air):
$$H_c = H_{c1} + \left[\frac{(\rho_c \cdot Q_c^3 \cdot D_c^4 \cdot K_{pc} - \rho_1 \cdot Q_1^3 \cdot D_1^4 \cdot K_{p1})}{(\rho_2 \cdot Q_2^3 \cdot D_2^4 \cdot K_{p2} - \rho_1 \cdot Q_1^3 \cdot D_1^4 \cdot K_{p1})}\right] \cdot (H_2 - H_1) \quad \text{Eq. I.47}$$

or for incompressible flow at a constant density $H_c = H_{c1} + \left[\frac{(Q_c^3 \cdot D_c^4 - Q_1^3 \cdot D_1^4)}{(Q_2^3 \cdot D_2^4 - Q_1^3 \cdot D_1^4)}\right] \cdot (H_2 - H_1) \quad \text{Eq. I.47a}$

I.7 General dimensional interpolation between tested fans

This section describes the interpolation method used to develop ratings for a fan where a single geometric feature is varied. Examples include changes in axial fan blade pitch, centrifugal fan blade width and the distance from an impeller to a separating panel on fans for fan arrays. A change in fan impeller diameter is not considered a single geometric feature; changes to fan impeller diameter are covered in Sections I.4 and I.6.

I.7.1 Range of application

The interpolation method may be applied only between two fan tests at the same speed. The interpolated dimension for the calculated fan must be between the dimensions for the two tested fans.

$$X_1 \leq X_c \leq X_2 \quad \text{Eq. I.48}$$

I.7.2 Interpolation between corresponding points of a fan curve

All interpolation must be between corresponding points of a fan curve. This is accomplished by dividing each tested fan curve into an equal number of equally spaced pressure increments from the minimum to the maximum tested pressure. Alternatively, the tested fan curve can be divided into an equal number of equally spaced airflow increments. For fans with an unstable region on their fan curve, only the stable region is divided into equal increments.

Note that this requirement likely will require interpolation along fan curves 1 and/or 2 prior to making the following calculations. This interpolation is not covered in this annex. A moving cubic polynomial curve fit between the nearest four determinations is suggested.

Interpolation then is conducted between successive points on the two tested fan curves. An example of pitch interpolation is shown in Figure I.1.

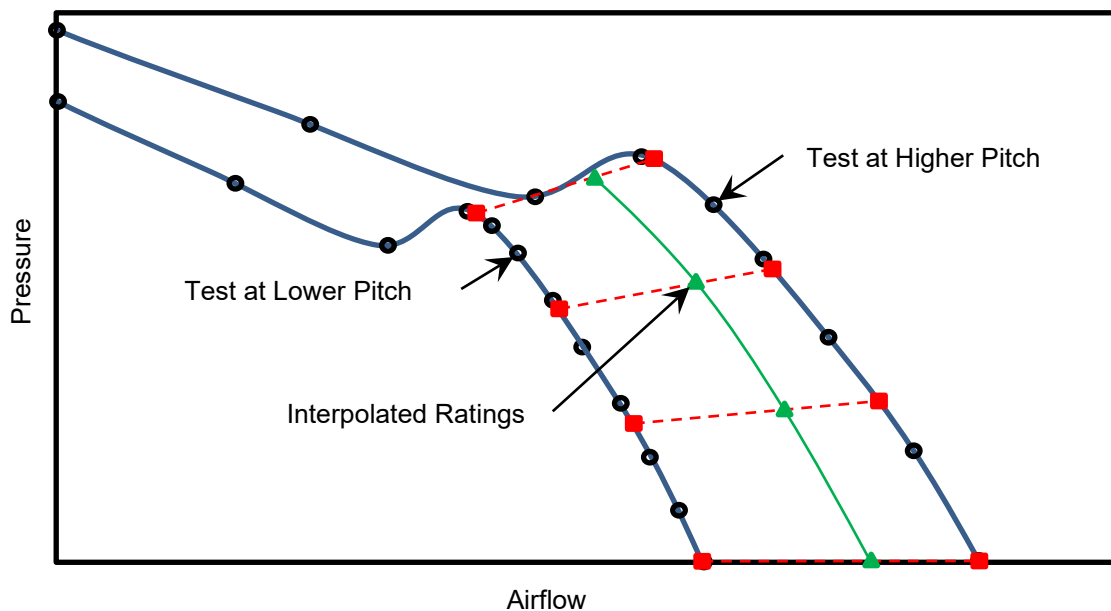

Figure I.1—Example of Blade Pitch Interpolation

I.7.3 Airflow

Airflow shall be calculated using linear interpolation of the value X :

$$Q_c = Q_1 + \left(\frac{X_c - X_1}{X_2 - X_1} \right) \cdot (Q_2 - Q_1) \quad \text{Eq. I.49}$$

1.7.4 Pressure

Fan pressure (total or static) shall be calculated using linear interpolation of the value X :

$$P_c = P_1 + \left(\frac{X_c - X_1}{X_2 - X_1} \right) \cdot (P_2 - P_1) \quad \text{Eq. 1.50}$$

1.7.5 Power

Fan input power varies linearly with air power:

$$H_c = H_1 + \left(\frac{Q_c \cdot P_c - Q_1 \cdot P_1}{Q_2 \cdot P_2 - Q_1 \cdot P_1} \right) \cdot (H_2 - H_1) \quad \text{Eq. 1.51}$$

At zero airflow (shutoff):

$$H_c = H_1 + \left[\frac{P_c^{1.5} \cdot \left(\frac{\rho_1}{\rho_c} \right)^{0.5} - P_1^{1.5}}{P_2^{1.5} - P_1^{1.5}} \right] \cdot (H_2 - H_1) \quad \text{Eq. 1.52}$$

At zero pressure (free air):

$$H_c = H_1 + \left(\frac{\rho_c \cdot Q_c^3 - \rho_1 \cdot Q_1^3}{\rho_2 \cdot Q_2^3 - \rho_1 \cdot Q_1^3} \right) \cdot (H_2 - H_1) \quad \text{Eq. 1.53}$$

AMCA Membership Information
<http://www.amca.org/member>

AMCA International Headquarters and Laboratory
www.amca.org

AMCA White Papers
www.amca.org/whitepapers

Searchable CRP Database of AMCA Certified Products
www.amca.org/certified

VISIT THE AMCA STORE

AMCA provides its Publications (no cost) and Standards (cost) through the AMCA Store. Any document selected will be bring up options for a free or at-cost PDF, and, where applicable, at-cost print (hard copy), redline, multi-user license and PDF + print options. To access member-only pricing and access your 50% discount, first log into MyAMCA or click on MyAMCA from within the AMCA website. For more information on AMCA Publications and Standards, visit www.amca.org/store.



Air Movement and Control Association International

AMCA Corporate Headquarters

30 W. University Drive, Arlington Heights, IL 60004-1893, USA
communications@amca.org Ph: +1-847-394-0150 www.amca.org

The Air Movement and Control Association International Inc. is a not-for-profit association of the world's manufacturers of air system equipment, such as fans, louvers, dampers, air curtains, airflow measurement stations, acoustic attenuators and other air system components for the industrial and commercial markets.