

DOCKETED	
Docket Number:	20-LITHIUM-01
Project Title:	Lithium Valley Commission
TN #:	237005
Document Title:	Summary Harnessing Solar Energy during import of seawater into the Salton Sea Segment ++(III) - Relevant to the Comment
Description:	N/A
Filer:	Nikola Lakic
Organization:	Geothermal Worldwide, Inc.
Submitter Role:	Public
Submission Date:	3/5/2021 11:47:06 AM
Docketed Date:	3/5/2021

Harnessing Energy and Water in the Salton Sea (Segm. III)

(System for Harnessing Solar Energy)

Nikola N. Lakic.

Geothermal Worldwide, Inc.

78-365 Hwy 111, #402, La Quinta, CA 92253

E-mail address: nlakic@GeothermalWorldwide.com

Keywords

Geothermal, Environment, Wildlife Sanctuary, importing seawater, Tourism, Renewable Energy, Electricity, Solar Power, Geothermal Power, Heat Exchanger, In-Line-Pump/Generator, Geothermal Self Contained In-Ground Geothermal Generator, Desalinization, Lithium.

ABSTRACT

The Salton Sea in California is a terminal lake with reduced inflow from the Colorado River as a result of the water transfers related to the Quantification Settlement Agreement (QSA). The Lake is shrinking and exposing the receding shoreline (toxic playa) to the elements and facing incoming environmental disaster.

The presented proposal includes an architectural element that harmoniously incorporates several patented technologies into a self-sustaining organism. It is a long-term solution for the restoration of the Salton Sea.

The presented proposal includes several options based on the same concept: 1) Dividing the Lake into three sections; 2) Importing seawater from the Ocean, and; 3) Harnessing prevalent geothermal energy.

In this segment (III), the emphasis is on using the pipeline for importing seawater as a foundation for solar panels assemblies.

The presented system for importing seawater and using the pipeline as a foundation for the solar panels is a fundamental value in determining the feasibility of the phase of importing seawater into the Salton Sea which is the essential phase for harnessing geothermal energy and for the restoration of the Salton Sea.

The pipeline provides a substantial surface that otherwise would need to be selected, leased, or purchased. By using the pipeline as a foundation for solar panels assembly it eliminates expenses for leasing or purchasing a location, therefore, increasing the revenue.

Presented Thermo-Optical Solar system (TOS) consists of a panel and/or dish with several indentations in the shape of parabolas with a reflective coating inside and a transparent cover with lenses. The panel or dish also contains a closed-loop heat exchange system with the first heat exchanger positioned in focal points of parabola and lenses, and a second heat exchanger positioned into the boiler of the binary power unit nearby. The power units consisting of the evaporator with a working fluid, a piston engine with generators, and a condenser.

1. Introduction

The solar farms on an industrial scale require a substantial surface of the land for solar panels positioned around power generating facilities. That land needs to be selected, leased, or purchased. The Conventional Photo Voltaic (PV) solar panels are efficient only about 15% -20%.

The pipeline corridor provides a substantial surface of the land that otherwise would need to be selected, leased, or purchased. By using the pipeline as a foundation for solar panels assembly 610 (See FIG. 1) eliminates expenses and increase the revenue. In this proposal is presented a new Thermo-Optical Solar system (TOS) which consists of a panel or dish (See FIG. 1 – 5).

Presented Thermo-Optical Solar system (TOS) consists of a panel and/or dish with several indentations in the shape of parabolas with a reflective coating inside and a transparent cover with lenses. The panel or dish also contains a closed-loop heat exchange system (See FIG. 1-4 and 6) with the first heat exchanger positioned in focal points of parabola and lenses, and a second heat exchanger positioned into the boiler of the binary power unit nearby (See FIG. 1). The power units consisting of the evaporator with working fluid, pistons with generators, and a condenser (See Fig. 7-8). There is also a battery pack (See FIG. 1).

The dish has a parabolic indentation with a reflective surface to reflect sunrays into the focus of the parabolic cavity where the heat exchanger is positioned. This system also uses lenses to focus sunrays in an additional part of the heat-exchanger positioned in a focal point of the lances. The synthetic oil circulates through the first heat-exchanger positioned into panel and/or dish, which are connected to the second heat exchange positioned into the evaporator of the power unit which generates electricity(See FIG. 6- 8). The power unit consists of a Boiler (evaporator), pistons unit, gearbox, generators, and condenser.

In this presentation, the Thermo-Optical solar system use breeze and cooler temperature of the pipeline for cooling the condensers (See Fig. 1). The presented system for harnessing solar energy used in the process of importing seawater is a necessary part for the restoration of the Salton Sea, CA, although technology is not limited to the Salton Sea project. The presented system can be used in the residential sectors and for desalinization and production of potable water.

The presented “thermo-optical solar system” has not been tested yet, but it is realistic to expect that it can generate multi-fold electricity per unite surface than a photovoltaic system because power density is substantially higher. The size of the panels is similar to the conventional PV panels with slightly higher thickness.

1.1 Overview of the Proposal for Harnessing Solar Energy in the Process of Importing Seawater for the Restoration of the Salton Sea and for Harnessing Geothermal Energy.

The presented “thermo-optical solar system” has not been tested yet, but it is realistic to expect that it can generate multi-fold electricity per unit surface than the photovoltaic system because power density is substantially higher.

1.2 Preliminary Estimate for Cost and Energy generated from Thermo-Optical Solar System used in the process of importing Sea Water from the Ocean into the Salton Sea.

The length of most of the proposed pipeline routes (5 although here because of limited space presented only 2) is about 160 miles. Here for easier calculation will be calculated the length of the pipeline to be 1 mile. For any particular distance, final results can be easily calculated.

There are two solar panels assembly on each segment of the pipeline (see FIG. 1). One solar assembly has two sets of three panels of dimensions about 3.5' x 5.2'. The length of one segment of the pipeline is about 30'.

1 mile : 30' = 5,280 feet : 30' (length of a segment) = 176 pipeline segments.

One set of panels 5.2' x 3.5' = 18.2 square feet; => 18.2 square feet x 6 panels = 109.2 square feet.
109.2 square feet x 2 assembly = 218.4 square feet.

218.4 square feet (two assembly) x 176 (segments) = 38,438.4 square feet.

38,438.4 square feet = 0.882332 acres.

One mile of a pipeline can have 0.882332 acres of panels.

0.882332 acres (of panels) x 100 miles (length of pipeline) = 88.2 acres of panels.

(1 acre of solar panels produces 1.5 MWh – 1.68 MWh).

88.2 acres (of panels) x 1.5 MWh = 132.34 MWh

0.882332 acres (of panels) x 160 miles (length of pipeline) = 141.137 acres of panels.

141.137 acres (of panels) x 1.5 MWh = 211.75968 MWh.

1.3 Preliminary Cost Estimate of the Solar Panel Assembly System:

The preliminary cost estimate of one set of the “Thermo-Optical Solar (TOS) panel assembly (see FIG. 1) costs about \$ 2,000. The preliminary estimate of two sets of the “Thermo-Optical Solar (TOS) panel assembly assembled on one pipeline segment 30 feet long cost about \$4,000 (See FIG. 1 and 2).

176 (pipeline segment per mile) x \$4,000 = \$704,000; Assuming that every two pipeline segments there are a power unit and a battery.

The preliminary cost estimate of one power unit is \$3,000;

The preliminary cost estimate of one battery unit is \$3,000;

Let's call it power pack about \$6,000.

176 segments: 2 = 88 power pack;

88 power pack x \$6,000 = \$528,000;

For one mile the cost of (88 power pack = \$528,000) + (352 Thermo-Optical Solar (TOS) panel assembly = \$704,000) = \$1,232,000;

For 160 miles the cost for the Thermo-Optical Solar system is \$197,120,000 ~ **\$200,000,000**;

1.4 Preliminary Estimate for Cost and Energy generated from the Thermo-Optical Solar System used in importing Sea Water from the Ocean into the Salton Sea Routes 1 and 2.

1.4.1 Preliminary estimate for Energy, Cost, and Revenue Generated, of the solar system on the Route 1:

Photo Voltaic PV panels on 160 miles (length of pipeline) = 141.137 acres of panels ==>.

141.137 acres (of panels) x 1.5 MWh (average production of electricity by PV system) = 211.75968 MWh.

Although the a several-fold ratio would be more realistic ratio, here is calculated the only two-fold ratio. 211.75968 MWh. X 2 = **423.519 MWh.**

Thermo-Optical Solar (TOS) System installed on pipeline Route #1 can generate 423,519 MWh.

Revenue generated from the Thermo Optical Solar (TOS) system installed on pipeline Route #1:

423,519 MWh x \$60 = \$25,411 per hour;

\$ 25,411 x 6 hours = \$152,466 per day;

\$152,466 x 300 days (sunny days in area per year) = \$45,740,052 per year.

Revenue generated from the Thermo-Optical Solar (TOS) System installed on pipeline Route #1 would be at least **\$45,740,052** per year.

1.4.2 Preliminary estimate for Energy, Cost, and Revenue Generated, of the solar system on the Route 2:

Photo Voltaic PV panels on 200 miles (length of pipeline) = 176.4664 acres of panels ==>.

176.4664 acres (of panels) x 1.5 MWh = 264.6996 MWh.

(1 acre of solar panels produces 1.5 MWh – 1.68 MWh).

Although a several-fold ratio would be a more realistic ratio, here is calculated the only two-fold ratio.

264.6996 MWh x 2 -fold estimate = 529.34 MWh.

The Thermo-Optical Solar System installed on route #2 pipeline can generate 529.34 MWh.

529.34 MWh - 275.7 MWh (energy needed for pumping up seawater) = 253.64 MWh.

The remaining 253.64 MWh can be sold to the grid.

Revenue: 253.64 MWh x \$60 = \$15,218 per hour;

\$15,218 x 6 hours = \$91,310 per day;

\$91,310 x 300 days = **\$27,393,120** per year;

2. Overview of the Proposal for Harnessing Solar Energy from the pipeline system for irrigation for the farmland Northern and Southern area from the Salton Sea.

See Segment I, Figs 3, 4, and 8.

2.1 Preliminary Calculation for Harnessing Solar Energy from the pipeline system used for irrigation for the farmland area Southern from the Salton Sea:

The presented proposal shows south area from the Lake (from the Lake to the border with Mexico) having three main pipelines (central, western, and eastern) and numerous perpendicular ribs lines (See segment I, FIGS. 3, 4, 5).

2.1.1 Preliminary estimate for Energy Generated of the solar system on the pipeline system used for irrigation for the farmland area Southern from the Salton Sea:

The rough estimate of the length of all together pipelines is about 870 miles (40 miles West line + 50 miles Central line + 60 miles eastern line = 150 miles + (24 ribs lines x 30 miles = 720 miles) => 870 miles.

Presented “thermo-optical solar system” has not been tested yet, but it is realistic to expect that it can generate multi-fold electricity per unite surface than photovoltaic system because power density is substantially higher.

Photo Voltaic PV panels on 870 miles (length of pipeline) = 767.43 acres of panels ==>.

767.43 acres (of panels) x 1.5 MWh (average production of electricity by PV system) = 1,151.145 MWh.

Although several-fold ratio would be a more realistic ratio, here is calculated the only two -fold ratio. 1,151.145 MWh x 2 = **2,302.29 MWh.**

2.1.2 Preliminary estimate for Revenue Generated, of the solar system on the pipeline system used for irrigation for the farmland area Southern from the Salton Sea:

The Thermo-Optical Solar System installed for the irrigation for the farmland area Southern from the Salton Sea can generate about 2,302.29 MWh.

Revenue: 2,302.29 MWh x \$60 = \$138,137 per hour;

\$138,137 x 6 hours = \$828,824 per day;

\$828,824 x 300 days = **\$248,647,200** per year;

2.1.3 Preliminary Calculation for the Cost Estimate for the Thermo-Optical Solar System used on the pipeline system for irrigation for farmland Southern area of the Salton Sea:

There are two solar panels assembly on each segment of the pipeline (See FIG. 1). One solar assembly has two sets of three panels of dimensions about 3.5' x 5.2'. The length of one segment of the pipeline is about 30'.

The preliminary cost estimate of one set of the "Thermo-Optical Solar (TOS) panel assembly cost about \$2,000. Preliminary estimate of two sets of the "Thermo-Optical Solar (TOS) panel assembly assembled on one pipeline segment 30 feet long cost about \$4,000.

176 (pipeline segment per mile) x \$4,000 = \$704,000 per mile;

Assuming that every two pipeline segments there are a power unit and a battery.

Preliminary cost estimate of one power unit is about \$3,000;

Preliminary cost estimate of one battery unit is about \$3,000;

Let's call it power pack \$6,000.

176 segments / 2 = 88 power pack per mile.

88 power pack x \$6,000 = \$528,000;

For one mile the cost of (88 power pack = \$528,000) + (352 Thermo-Optical Solar (TOS) panel assembly = \$704,000) = \$1,232,000;

For 870 miles of the Thermo-Optical Solar System preliminary cost is \$1,151,010,000 ~ **\$1,200,000,000;**

2.1.4 Preliminary Calculation for the Cost Estimate for the pipeline system for irrigation for farmland Southern area of the Salton Sea:

Pipeline distance is about 870 miles.

The range of cost today of installed pressure pipe of 48-inch diameter in various terrains is about \$600 – \$1,000 per linear foot.

Because of preferred topography in this area which has an advantage in pipeline cost it is assumed \$600 per linear foot.

One mile $5,280' \times \$600 = \$3,168,000$.

$\$3,168,000 \times 870 \text{ miles relatively flat terrain} = \mathbf{\$2,756,160,000}$.

2.2 Preliminary estimate for Energy and Revenue Generated, and Cost of the solar system on the pipeline system used for irrigation for the farmland area Northern from the Salton Sea:

Since the farmland area north of the Salton Sea is about half of the farmland area south of the Salton Sea, the results of the “Harnessing Solar Energy” and “Cost Estimate for the Thermo-Optical Solar System” are simply divided on half.

Therefore the preliminary estimate for energy generated is $2,302.29 \text{ MWh} : 2 = \mathbf{1,151.14 \text{ MWh}}$;

The preliminary estimate for revenue generated is $\$248,647,200 : 2 = \mathbf{\$124,323,600}$ per year;

The cost estimate for the Solar System is $\$1,200,000,000 : 2 = \mathbf{\$600,000,000}$.

The cost estimate for the pipeline system is $\$2,756,160,000 : 2 = \mathbf{\$1,378,080,000}$.

2.3 Preliminary estimate for Energy and Revenue Generated, and Cost of the solar system on the pipeline system used for irrigation for the farmland area Northern and Southern from the Salton Sea:

Preliminary estimate for Energy Generated is $2,302.29 \text{ MWh} + 1,151.14 \text{ MWh} = \mathbf{3,453.43 \text{ MWh}}$ per year;

Preliminary estimate for Revenue Generated is $\$248,647,200 + \$124,323,600 = \mathbf{\$372,970,800}$ per year;

The cost estimate for the Solar System is $\$1,200,000,000 + \$600,000,000 = \mathbf{\$1,800,000,000}$.

The cost estimate for the Pipeline System is $\$2,756,160,000 + \$1,378,080,000 = \mathbf{\$4,134,240,000}$.

3. Illustrations of the Segment (III) - Importing Seawater for the Restoration of the Salton Sea.

Segment (III)

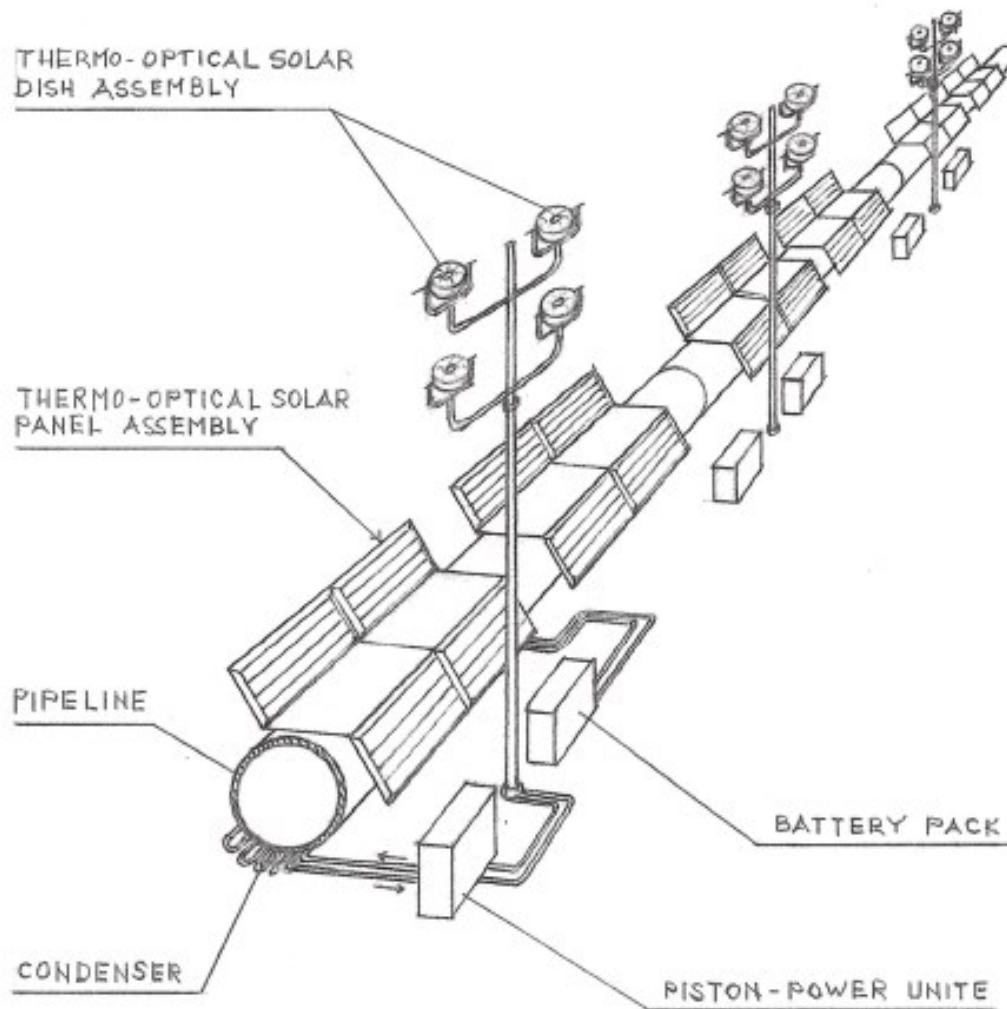

FIG. 1 – **Perspective View of a Pipeline with Solar Panels attached to the Pipeline in combination with alternative Solar Dish System aside**

Segment (III)

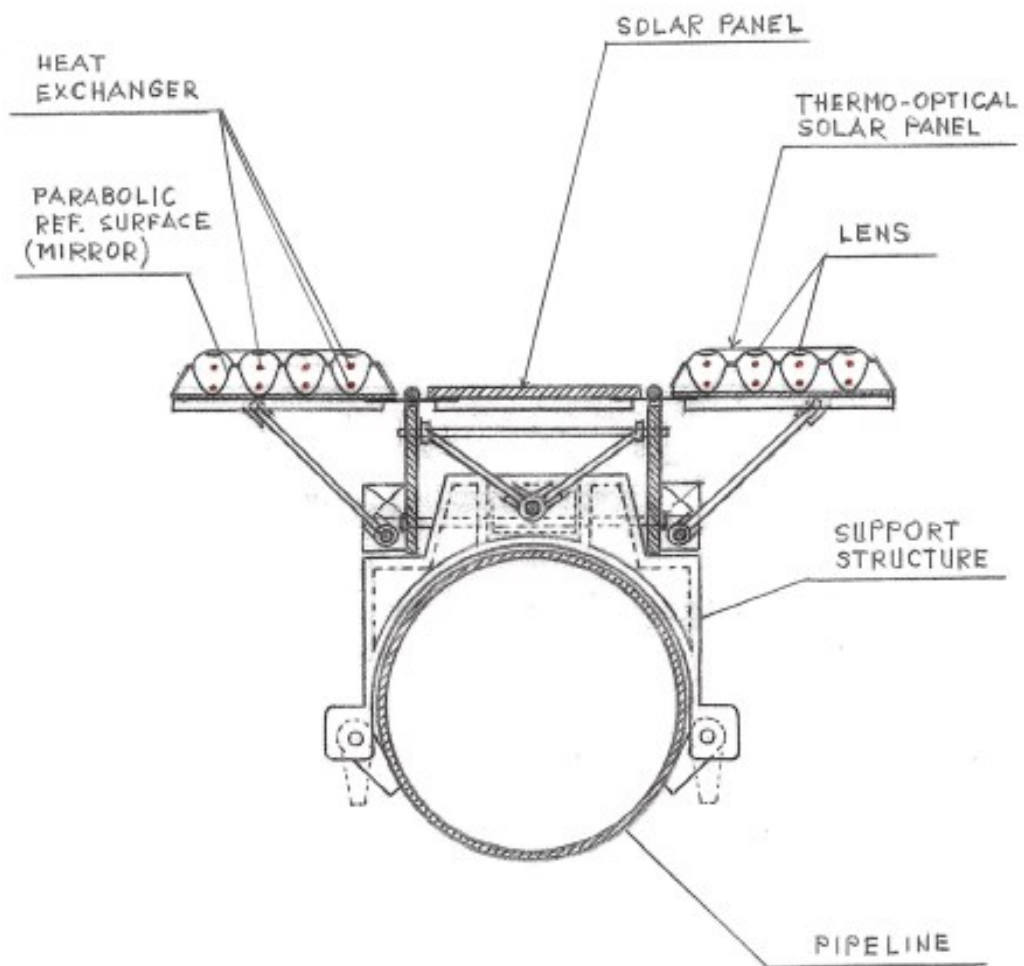

FIG. 2 – Cross-sectional View of a Solar Panel Assembly

Segment (III)

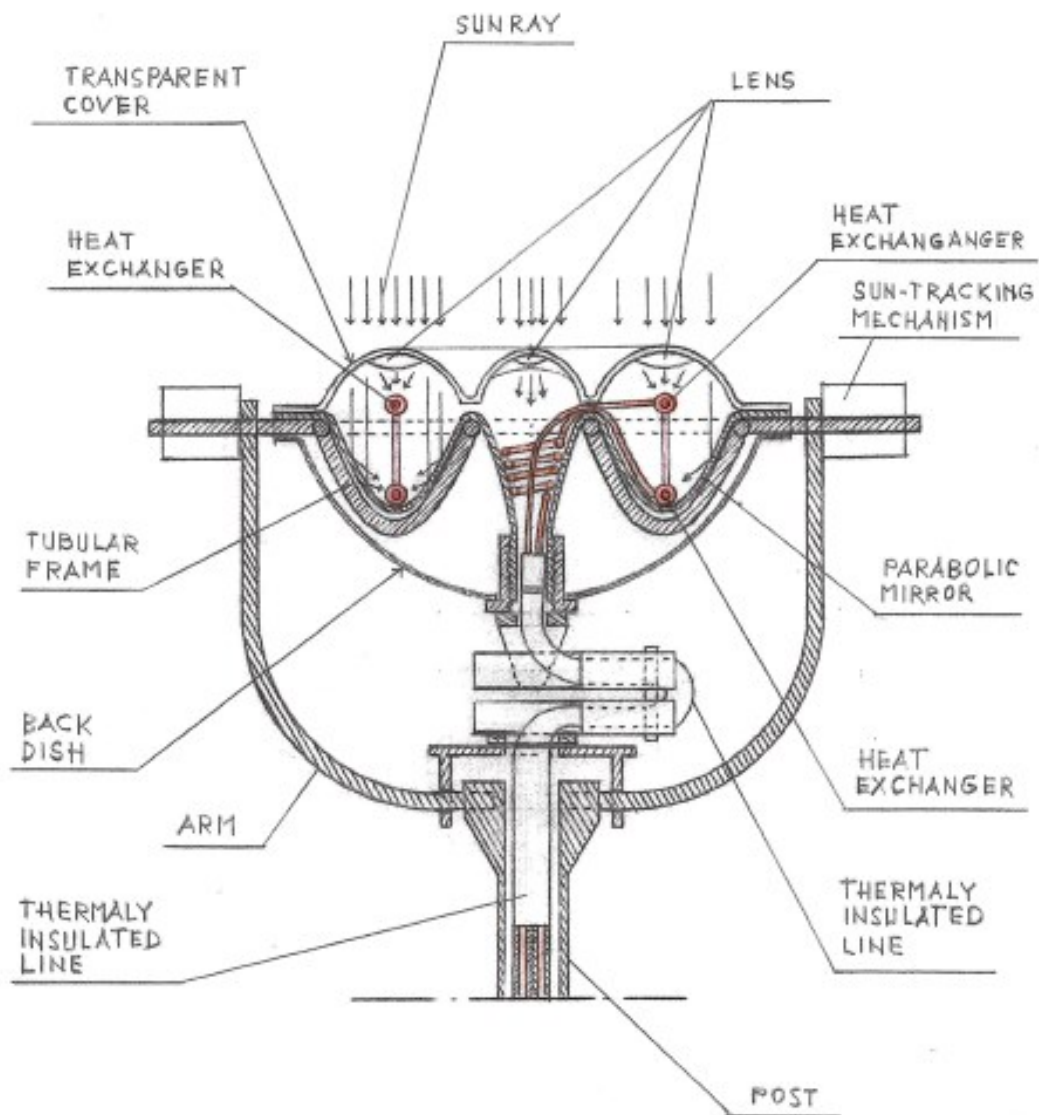

FIG. 3 – Cross-sectional View of the "Thermo-Optical Solar Dish"

Segment (III)

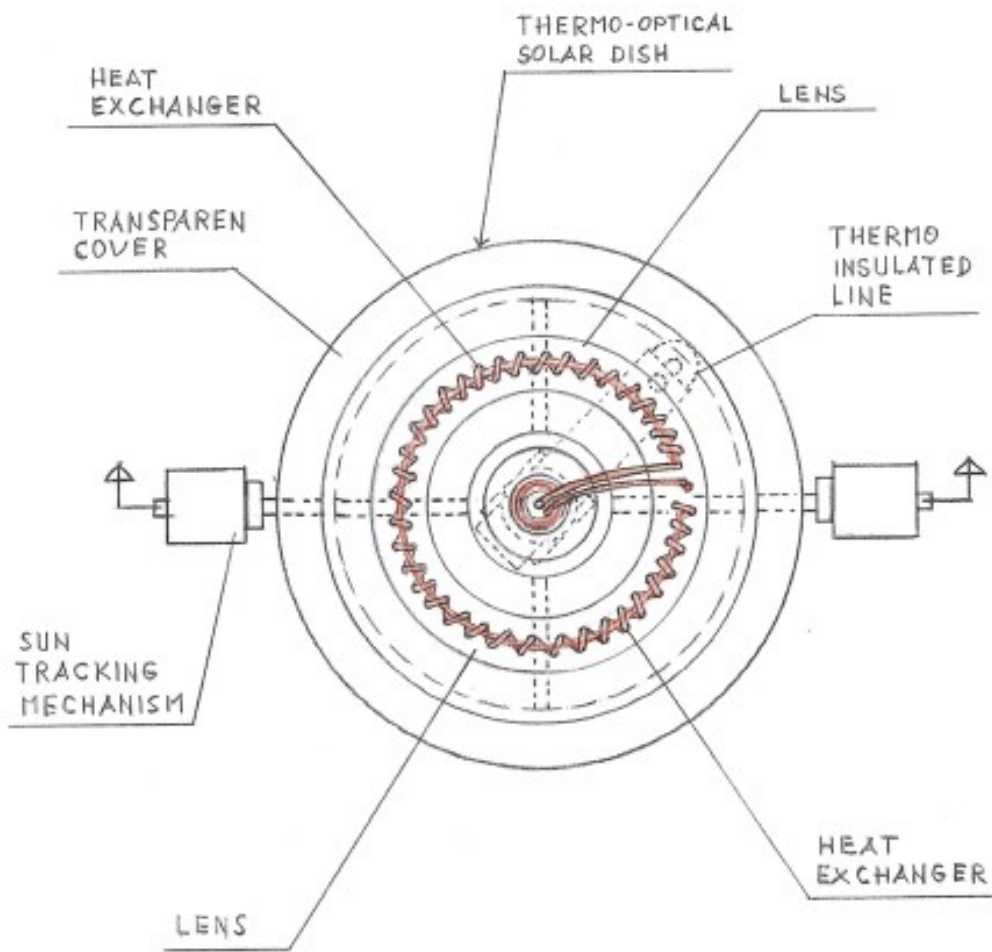

FIG. 4 – Plain View of a "Thermo-Optical Solar Dish"

Segment (III)

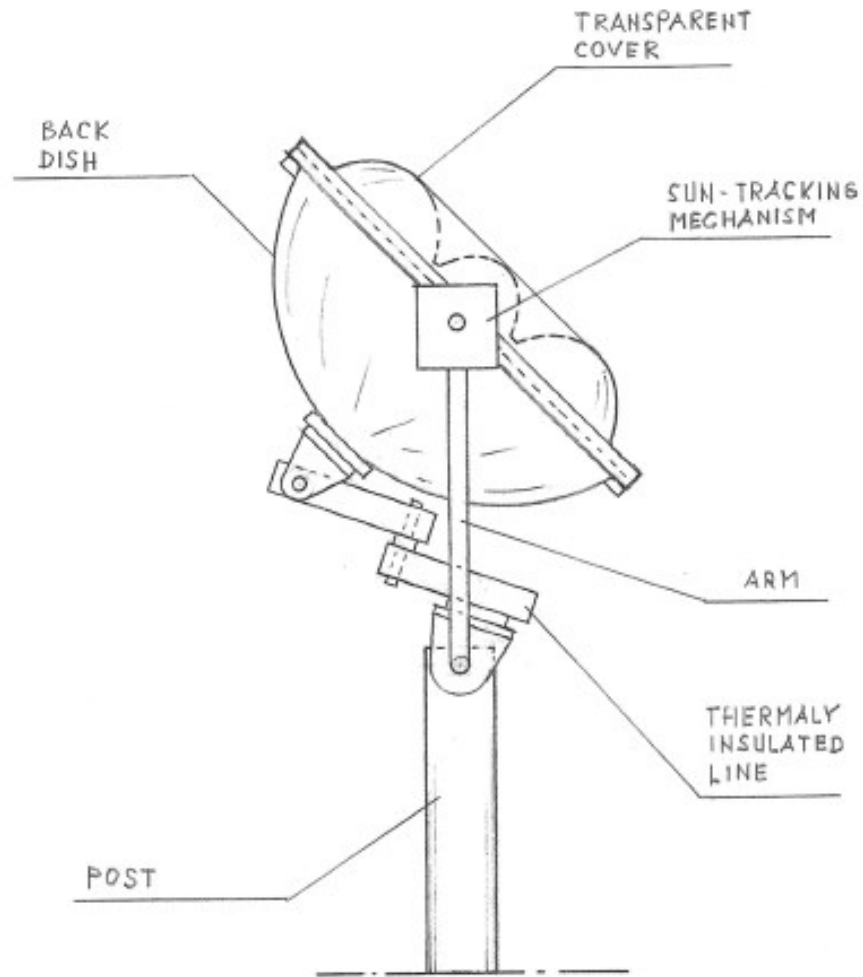

FIG. 5 – Side View of a "Thermo-Optical Solar Dish"

Segment (III)

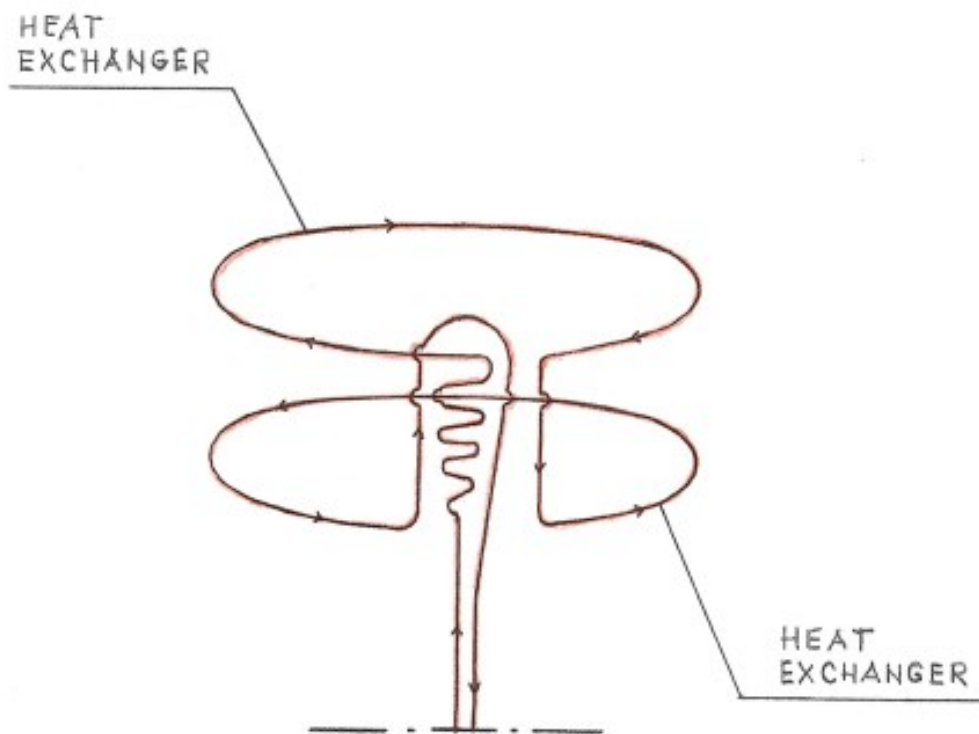

FIG. 6 – Schematic diagram of the flow of the synthetic oil through the heat exchanger of the Thermo-Optical Solar Dish

Segment (III)

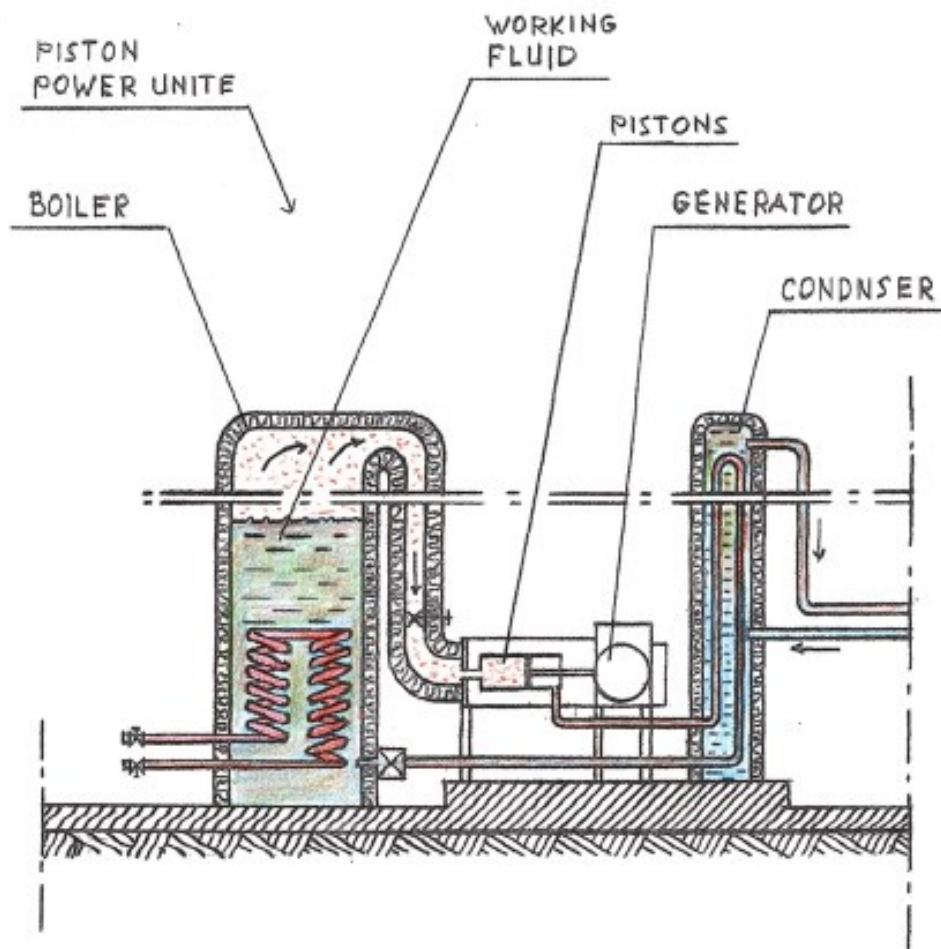

FIG. 7 – Schematic Cross-sectional View of a Power Unit

Segment (III)

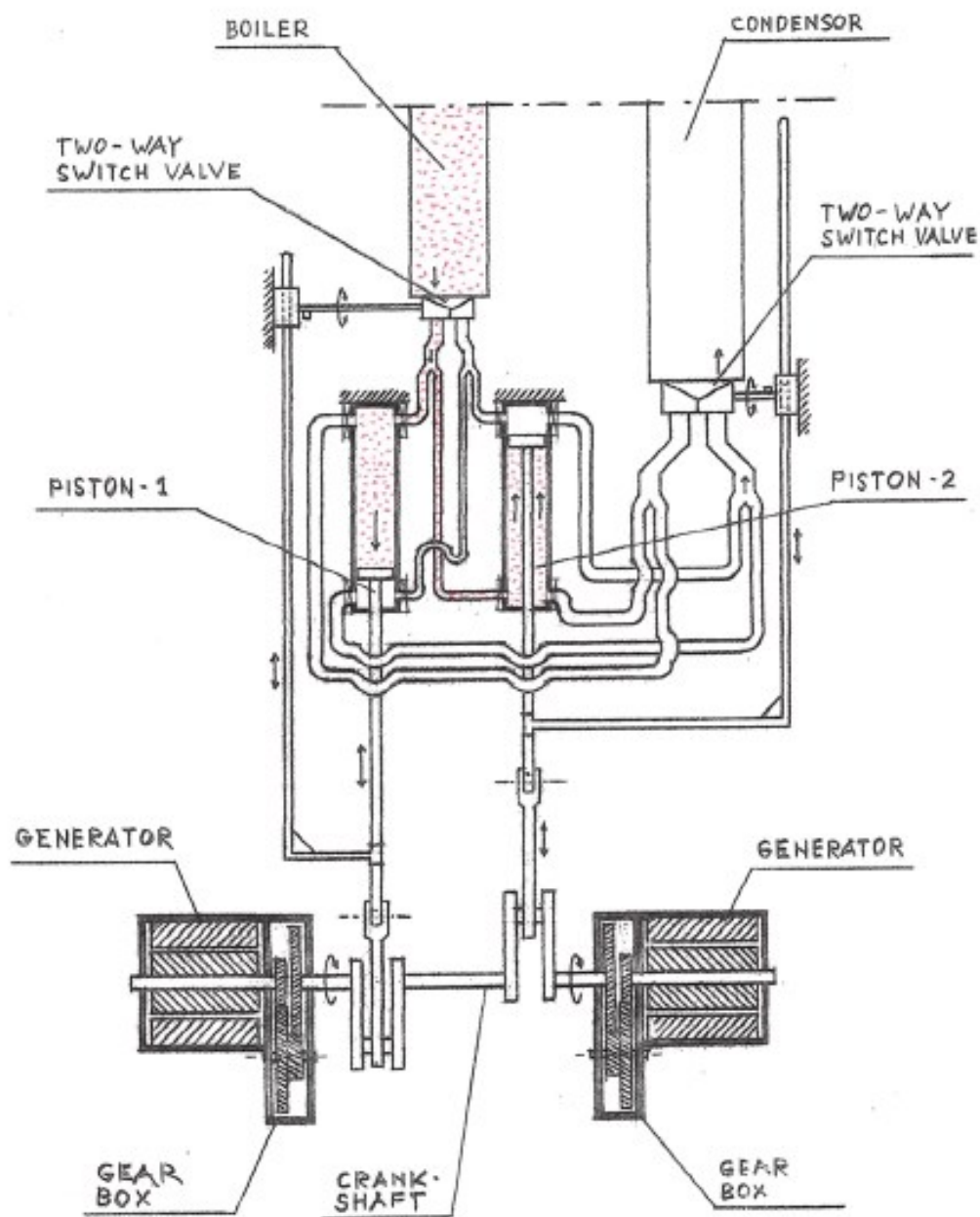

FIG. 8 – Schematic Diagram of a Piston Power Unit
– stroke one

Segment (III)

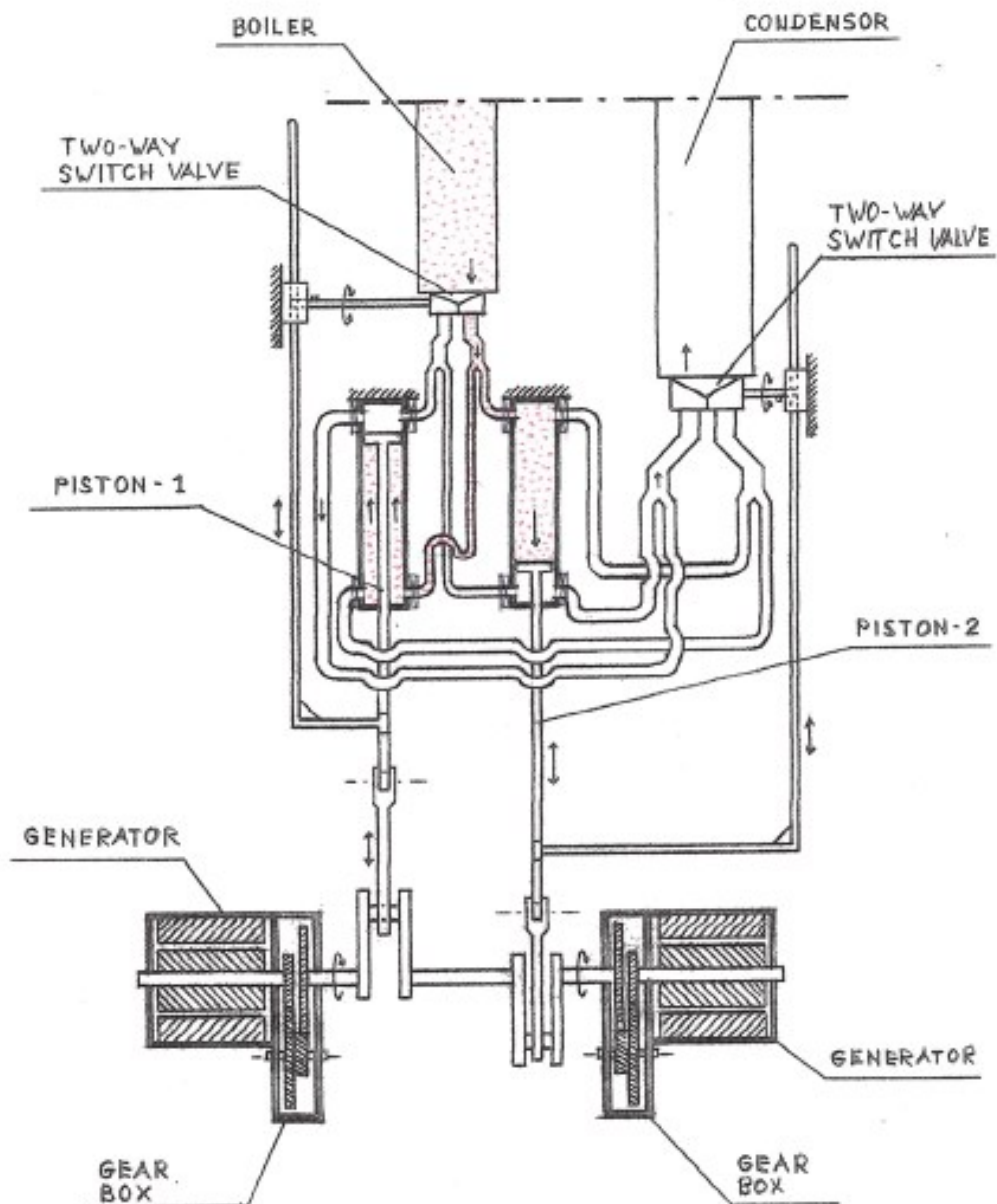

FIG. 9 – Schematic Diagram of a Piston Power Unit –
stroke two

3. Conclusion:

Harnessing solar energy in combination with the pipeline system for importing seawater makes a phase of importing seawater self-sustainable and profitable. Importing seawater is a fundamental phase of this comprehensive project on which other phases depend and is an essential element in providing the necessary water for harnessing geothermal energy in the area and is an essential element for the restoration of the Salton Sea.

Acknowledgment

The 3.5 km Temperature Map is courtesy of the SMU Geothermal Laboratory and Dr. David Blackwell, Dallas Texas.

REFERENCES

- U.S. Patent No. 7,849,690; Entitled: “Self-Contained In-Ground Geothermal Generators” (SCI-GGG); Issued on Dec.14, 2010;
- U.S. Patent No. 8,281,591; Entitled: “Self-Contained In-Ground Geothermal Generators” (SCI-GGG); Issued on October 9, 2012;
- U.S. Patent No. 8,713,940; Entitled: “Self-Contained In-Ground Geothermal Generators”; Issued on May 6, 2014;
- U.S. Patent No. 9,206,650; Entitled: “Apparatus for Drilling Faster and Wider Wellbore; Issued on December 8, 2015;
- U.S. Patent No. 9,978,466; Entitled: “Self-Contained In-Ground Geothermal Generator and Heat Exchanger with In-Line Pump; Issued on May 22, 2018;
- U.S. Patent No. 9,982,513; Entitled: “Apparatus for Drilling Faster and Wider Wellbore with Casing; Issued on May 29, 2018;
- U.S. Patent No. 9,995,286; Entitled: “Self-Contained In-Ground Geothermal Generator and Heat Exchanger with In-Line Pump and Several Alternative Applications; Issued on June 12, 2018;