

DOCKETED	
Docket Number:	22-BSTD-01
Project Title:	2025 Energy Code Pre-Rulemaking
TN #:	249621
Document Title:	Bradford White Corporation Comments - Bradford White Corporation Comments to 2025 CASE Study- Multifamily HPWH Ventilation Standards
Description:	N/A
Filer:	System
Organization:	Bradford White Corporation
Submitter Role:	Public
Submission Date:	4/12/2023 5:49:45 AM
Docketed Date:	4/12/2023

*Comment Received From: Bradford White Corporation
Submitted On: 4/12/2023
Docket Number: 22-BSTD-01*

**Bradford White Corporation Comments to 2025 CASE Study -
Multifamily HPWH Ventilation Standards**

Additional submitted attachment is included below.



April 12, 2023

California Energy Commission
Re: Docket #: 22-BSTD-01
Project Title: 2025 Energy Code Pre-Rulemaking
1516 Ninth Street
Sacramento, CA 95814

[Electronically Submitted to: info@title24stakeholders.com; Cc: jhaile@frontierenergy.com; jfeng@trccompanies.com]

Re: Bradford White Corporation Comments to Multifamily Domestic Hot Water Codes and Standards Enhancement (CASE) Proposal - Proposed Ventilation Standards for Heat Pump Water Heater Installations

Dear California Energy Commission and Title 24 Stakeholders:

On behalf of Bradford White Corporation (BWC), we would like to thank you for the opportunity to comment on the California Energy Commission (CEC) 2025 Energy Code Pre-Rulemaking, proposed ventilation standards for heat pump water heater (HPWH) installations.

BWC is an American-owned, full-line manufacturer of residential, commercial, and industrial products for water heating, space heating, combination heating, and water storage. In California, a significant number of individuals, families, and job providers rely on our products for their hot water and space heating needs.

Standardizing Required Ventilation Methodology

The CASE Team has proposed new mandatory requirements for how consumer integrated HPWHs shall be ventilated in different installation spaces. The code language is proposing to establish specific air volume per kBtu of total compressor output capacity for installations in confined spaces. While we understand the intention is to ensure efficient performance of HPWHs, we believe that the methodology for determining adequate ventilation is something manufacturers already provide guidance on. BWC provides specific guidance for installation of our AeroTherm® HPWH including recommended air space, louvered doors and ducting requirements for installation in small spaces, recommended clearances for servicing and proper air exchange and ambient temperatures for compressor operation. Pages 10-12 of our product manual¹ (see Attachment A) discuss installation for ensuring optimal efficiency. In our research, other manufacturers of HPWHs have similar instructions in their product installation and operation manuals.

¹ [residential_heat_pump_aerotherm_re_series_con_iomanual_re2h50s_re2h65t_re2h80t_52169.pdf](#)

Built to be the Best™

725 Talamore Drive • Ambler, PA 19002-1873 • 215-641-9400 • www.bradfordwhitecorporation.com



Many factors influence a heat pump compressor's output capacity rating. The capacity of the compressor only provides one variable of a very complex energy balance equation, and it happens to be the simplest part. To draw a correlation between cooling capacity and recommended room volume without a multitude of other assumptions, it may not ensure the desired efficiency outcomes the Energy Commission seeks. Proposing a minimum ventilation standard other than what manufacturers list in their specification sheets, may give designers, architects and installers a false expectation of the HPWH performance once installed.

HPWHs may not achieve the product's rated Uniform Energy Factor (UEF) once installed due to several factors including: ambient room temperature, available air volume to exchange heat, occupancy usage patterns, etc. Defining a prescriptive minimum room size and/or ventilation strategy for HPWHs is overly simplistic and does not take into consideration several design factors contributing to performance. A manufacturer that specifies 150 cubic feet per kBtu/h compressor output does not necessarily have a lower performing appliance than a manufacturer that specifies 100 cubic feet per kBtu/h compressor output. Installations must take into account where the intake and exhaust of a HPWH are located, clearances above and surrounding the HPWH for service and air exchange, compressor fan CFM, compressor size, ambient temperature etc. All of these considerations are site specific, product specific, and are largely addressed in manufacturer installation and operation manuals.

As an alternative to proposing a minimum ventilation standard based on compressor kBtu output, we recommend the CASE Team require the designer list the manufacturers' required ventilation space and method of ventilation (open space, ducts, louvered doors etc.) in the Residential Certificates of Installation Non-HERS (CF2R). This would provide clear direction to the building inspector and not conflict with manufacturers' installation and operation instructions. As a starting point, BWC has proposed changes to the code language, which are contained in Appendix A. BWC further recommends the CASE Team establish a manufacturer working group to define a standard or consistent method for determining how HPWHs perform in different installations. By working with manufacturers to standardize a method to determine HPWH performance, the CASE Team can ensure all consumer HPWH manufacturers are reporting consistently compared to one another.

BWC suggests that the CASE Team consider looking at AHRI Standard 540 Performance Rating of Positive Displacement Refrigerant Compressors². AHRI Standard 540 is a standard for reporting the performance of a compressor (cooling capacity, input power, mass flow, and current) across its entire operating envelop. The values of 45°F and 130°F for suction dew point and discharge dewpoint, shown in Table 4, below, provide a single point on a surface with an infinite number of possibilities over very wide range. These values roughly represent an operating point that the heat pump water heater will pass through when recovering from a draw during a standard Department of Energy Uniform Energy Factor (UEF) test. If the Energy Commission wishes to establish specific ventilation thresholds for HPWHs, it is important to consider the existing, required testing manufacturers go through, like UEF, as to not add any additional cost and burden to the product. The test conditions reference AHRI 540 Table 4 (SI). Reference Rating Conditions, shown below.

² Air-Conditioning, Heating, and Refrigeration Institute, 2020 Standard for Performance Rating of Positive Displacement Refrigerant Compressors, https://www.ahrinet.org/sites/default/files/2022-06/AHRI_Standard_540_%28I-P_and_SI%29_2020_Standard_for_Performance_Rating_of_Positive_Displacement_Refrigerant_Compressors_and_Compressor_Units.pdf

Built to be the Best™

725 Talamore Drive • Ambler, PA 19002-1873 • 215-641-9400 • www.bradfordwhitecorporation.com



Table 4 (SI). Reference Rating Conditions ^{1,2,3}								
Compression Cycle			Low Side		High Side – Subcritical		High Side – Transcritical	
Application	Rating Test Point	Cycle Type	Suction Dew Point Temperature, °C	Superheat, K (or Return Gas Temperature) ^{4,5} , °C	Discharge Dew Point Temperature, °C	Condenser Exit Sub Cooling ⁶ , K	Discharge Pressure, bar	Gas Cooler Exit Temperature, °C
AC and HP	Heating	Subcritical	-15	10 (-5)	35	0	NA ⁷	
	Cooling	Subcritical	10	10 (20)	45	0	NA ⁷	
Refrigeration	High	Subcritical	5	10 (20 ⁸)	50	0	NA ⁷	
		Subcritical (NH ₃)		5 (10)	50	0	NA ⁷	
		Transcritical (CO ₂)		10 (15)	NA ⁷		100	40
	Medium	Subcritical	-10	10 (20 ⁸)	45	0	NA ⁷	
		Subcritical (NH ₃)		5 (-5)	45	0	NA ⁷	
		Transcritical (CO ₂)		10 (0)	NA ⁷		90	35
	Low	Subcritical	-35	10 (20 ⁸)	40	0	NA ⁷	
		Subcritical (NH ₃)		5 (-30)	40	0	NA ⁷	
		Transcritical (CO ₂)		10 (-25)	NA ⁷		90	35
		Cascade / Booster		10 (5 ⁸)	-10	0	NA ⁷	

Notes:

1. If airflow across the compressor or other external methods of cooling are used to determine ratings, they shall be specified by the compressor manufacturer.
2. If liquid refrigerant injection is used to control compressor discharge temperature, without any derived subcooling benefits of the liquid entering the evaporator, it shall be specified by the compressor manufacturer.
3. Ratings are based on 35 °C ambient temperature surrounding compressor.
4. Return gas temperature entering the compressor is assumed to be useful superheat for capacity calculation.
5. Refer to Appendix D for superheat correction for capacity.
6. Refer to Appendix C for subcooling calculation for capacity.
7. NA: Not Applicable
8. Alternate return gas temperatures provided intentionally.

BWC thanks the CEC and Case Team for the opportunity to provide feedback on the proposed 2025 ventilation standards for HPWH installations. Please let me know if you have any questions or would like to schedule a meeting to discuss our comments further.

Respectfully Submitted,

Bradford White Corporation

Michael Corbett
 State Gov't Affairs & Product Specialist

Cc: E. Truskoski; T. Gervais; C. Sanborn; K. Doyle; B. DeJager; B. Ahee

Built to be the Best™

725 Talamore Drive • Ambler, PA 19002-1873 • 215-641-9400 • www.bradfordwhitecorporation.com



Appendix A: Proposed Revisions to Section 110.3

SECTION 110.3 – MANDATORY REQUIREMENTS FOR SERVICE WATERHEATING SYSTEMS AND EQUIPMENT

Section 110.3(c) – Installation: Recommends new subsection as follows:

7. Heat pump water heaters. Consumer integrated heat pump water heater (HPWH) installation shall meet the following requirements.
- a. ~~**Outdoor Design Conditions.** Consumer integrated HPWHs with compressor cutout temperatures above the Winter Median of Extremes temperature for the closest location, listed in Table 2-3 from Reference Joint Appendix JA2 may use outdoor air as the inlet air source if equipped with a backup heat source that engages when the compressor is unable to provide sufficient heat for domestic hot water.~~
 - b. **Design Conditions.** Consumer integrated HPWHs shall be installed consistent with the manufacturer's specified installation guidance for temperature and location.
 - e. **Ventilation Method.** Air for ventilation of consumer integrated heat pump water heaters (HPWHs) shall be obtained from the HPWH manufacturer for the model HPWH listed in the CF2R, by application of one of methods in subsections 1 through 4. Spaces joined to the installation space via the applied ventilation method (the ventilation space) shall have a minimum volume of 100 cu. ft. per kBtu of total compressor capacity for all HPWHs in the installation space. Only rooms or spaces directly communicating with the installation space or the ventilation space through openings that cannot be closed using doors or other movable barriers shall be considered part of the volume of the installation space or ventilation space.
 - i. ~~Installed without ducts in a space with a minimum volume equal to the larger of 100 cu. ft. per kBtu/hr of total compressor capacity for all individual HPWHs in space or the minimum installation space volume provided by the manufacturer for this method.~~ **Installed in a space, with minimum air volume for the listed model HPWH. Minimum air volume shall be obtained from the manufacturer's installation guidelines and listed in the CF2R. Manufacturer minimum air volume requirements shall be based on the Total Evaporator Capacity Method as follows:**
 1. **Total Evaporator Capacity Method.** Total compressor Evaporator Capacity be calculated using AHRI Standard 540, Table 4 reference conditions for refrigeration with a High rating test point.
 - a. The test conditions reference AHRI 540 Table 4 (SI). Reference Rating Conditions, shown below:

Built to be the Best™

725 Talamore Drive • Ambler, PA 19002-1873 • 215-641-9400 • www.bradfordwhitecorporation.com



Table 4 (SI). Reference Rating Conditions ^{1,2,3}								
Compression Cycle			Low Side		High Side – Subcritical		High Side – Transcritical	
Application	Rating Test Point	Cycle Type	Suction Dew Point Temperature, °C	Superheat, K (or Return Gas Temperature) ^{4,5} , °C	Discharge Dew Point Temperature, °C	Condenser Exit Sub Cooling ⁶ , K	Discharge Pressure, bar	Gas Cooler Exit Temperature, °C
AC and HP	Heating	Subcritical	-15	10 (-5)	35	0	NA ⁷	
	Cooling	Subcritical	10	10 (20)	45	0	NA ⁷	
Refrigeration	High	Subcritical	5	10 (20 ⁸)	50	0	NA ⁷	
		Subcritical (NH ₃)		5 (10)	50	0	NA ⁷	
		Transcritical (CO ₂)		10 (15)	NA ⁷		100	40
	Medium	Subcritical	-10	10 (20 ⁸)	45	0	NA ⁷	
		Subcritical (NH ₃)		5 (-5)	45	0	NA ⁷	
		Transcritical (CO ₂)		10 (0)	NA ⁷		90	35
	Low	Subcritical	-35	10 (20 ⁸)	40	0	NA ⁷	
		Subcritical (NH ₃)		5 (-30)	40	0	NA ⁷	
		Transcritical (CO ₂)		10 (-25)	NA ⁷		90	35
		Cascade / Booster		10 (5 ⁸)	-10	0	NA ⁷	

Notes:

- If airflow across the compressor or other external methods of cooling are used to determine ratings, they shall be specified by the compressor manufacturer.
- If liquid refrigerant injection is used to control compressor discharge temperature, without any derived subcooling benefits of the liquid entering the evaporator, it shall be specified by the compressor manufacturer.
- Ratings are based on 35 °C ambient temperature surrounding compressor.
- Return gas temperature entering the compressor is assumed to be useful superheat for capacity calculation.
- Refer to Appendix D for superheat correction for capacity.
- Refer to Appendix C for subcooling calculation for capacity.
- NA: Not Applicable
- Alternate return gas temperatures provided intentionally.

2.
 - ii. Installed without ducts in a space smaller than required by subsection 1 above, according to the following requirements:
 1. Minimum volume of the installation space shall be equal to the manufacturer’s **specification or larger. of 20 cu. ft. per kBtu/hr of compressor capacity for all individual HPWHs in the space or the minimum installation space volume provided by the manufacturer for this method; and**
 2. Installation space shall be vented to a communicating space in the same pressure boundary via permanent openings with the minimum total net free area equal to the **manufacturer’s specification or larger of 125 sq. in. plus 25 sq. in. per kBtu/hr of compressor capacity for all individual HPWHs in the space or the minimum net free area provided by the manufacturer for this method, and that meet the following requirements: Installation methods may include:**
 - a. Fully louvered doors with fixed louvers consisting of a single layer of fixed flat slats; or
 - b. Two permanent fixed openings, consisting of a single layer of fixed flat slat louvers or grilles, one commencing within 12 inches from the top of the enclosure and one commencing within 12 inches from the bottom of the enclosure.
 - c. **Other approved installation as specified by HPWH manufacturer.**
 3. Installed with ducts in any size space, according to **the HPWH manufacturer specifications. In addition, ducting must meet the following installation requirements:**
 - a. All ducts shall be sealed at all joints using mastic.

Built to be the Best™

725 Talamore Drive • Ambler, PA 19002-1873 • 215-641-9400 • www.bradfordwhitecorporation.com



- b. All wall, floor, and ceiling penetrations are sealed using caulk or spray foam to join the exterior surface of the duct or duct insulation to the penetrated assembly; and
 - c. Exhaust air ducts and all ducts which cross pressure boundaries shall be insulated to a minimum insulation level of R-6.
 - d. If only makeup air is ducted, installation space shall include fixed flat slat louvers or grilles in the bottom half of the room, and/or a door undercut with a minimum total free area equal to the **cross-sectional area** of the duct.
 - e. If only exhaust air is ducted, installation space shall include fixed flat slat louvers, grilles, and/or a door undercut with a minimum total net free area equal to the larger of 20 sq. in. or the minimum net free area provided by the manufacturer for this method.
 - f. If makeup and exhaust ducts both terminate within the same pressure boundary, airflow from termination points shall be diverted away from each other.
4. Installed using method for ventilation certified **specified** by the manufacturer **in the product literature**. ~~A letter from the manufacturer providing this certification shall be included with plans submitted to the enforcement agency for approval.~~

Built to be the Best™

725 Talamore Drive • Ambler, PA 19002-1873 • 215-641-9400 • www.bradfordwhitecorporation.com



Attachment A

Built to be the Best™

725 Talamore Drive • Ambler, PA 19002-1873 • 215-641-9400 • www.bradfordwhitecorporation.com





BRADFORD WHITE[®]

W A T E R H E A T E R S

Heat Pump Water Heater

INSTALLATION & OPERATION INSTRUCTION MANUAL

RE2H50S*-1NCTT
RE2H65T*-1NCTT
RE2H80T*-1NCTT



For your family's comfort, safety, and convenience we recommend this water heater be installed and serviced by a plumbing professional.



As required by the state of California Proposition 65.

ECO 8424
Effective: Feb 2022

238-52169-00D 6/30

CONGRATULATIONS!

You have purchased one of the finest water heaters on the market today!

This installation, operation and instruction manual will explain in detail the installation and maintenance of your new Heat Pump Water Heater. We strongly recommend that you contact a plumbing professional for the installation of this water heater.

We require that you carefully read this manual, as well as the enclosed warranty, and refer to it when questions arise. If you have any specific questions concerning your warranty, please consult the plumbing professional from whom your water heater was purchased. For your records we recommend that you write the model, serial number and installation date of your water heater in the maintenance section in the back of this manual.

This manual should be kept with the water heater.

Table of Contents

	Page
General Information	3
Water Heater Capacity	4
About the Control Panel	5
Operational Modes	6
Temperature Adjustment.....	7
Installation Instructions	8
Minimum Required Clearances.....	11
Water Supply Connections.....	13
Electrical Connections.....	17
General Operation	19
Maintenance.....	20
Anode Rod Maintenance and Service	23
Frequently Asked Questions (FAQ).....	25
Fault Codes.....	26
Notes	28

General Information

READ ALL INSTRUCTIONS BEFORE USING THE APPLIANCE

For your safety, the information in this manual must be followed to minimize the risk of fire or explosion, electric shock, and/or to prevent property damage, personal injury, or loss of life.

The warranty on this water heater is in effect only when the water heater is installed and operated in accordance with local codes and these instructions. The manufacturer of this heater will not be liable for any damage resulting from failure to comply with these instructions. Read these instructions thoroughly before starting.

This water heater must be installed in accordance with local codes. In the absence of local codes, install this water heater in accordance with the latest edition of the National Electrical Code.

⚠ WARNING

Incorrect operation of this appliance may create a hazard to life and property and will nullify the warranty.

Do NOT use this appliance if any part has been submerged in water. The plumbing professional responsible for the installation of this water heater should be contacted to inspect the appliance and to replace any part of the control system, including thermostat(s), that has been submerged in water.

⚠ WARNING

If the water heater has been subjected to flood, fire, or physical damage, turn off power and water to the water heater. Do NOT operate the water heater again until it has been thoroughly checked by qualified service personnel.

- Turn **OFF** power to water heater if it has been subjected to overheating, fire, flood, or physical damage.
- Do **NOT** turn on water heater unless it is filled with water.
- Do **NOT** turn on water heater if cold water supply shut-off valve is closed.

NOTE: Flammable vapors may be drawn by air currents from surrounding areas to the water heater.

Make sure that the rating plate on the water heater is referenced for certainty that the correct voltage is being supplied to the water heater.

⚠ WARNING

DO NOT store or use gasoline or other flammable, combustible, or vapors and liquids in the vicinity of this water heater or any other appliance. Keep rags and other combustibles away.

A sacrificial anode(s) is used to extend tank life. Removal of any anode, except for inspection and/or replacement, will nullify the warranty. In areas where water is unusually active, an odor may occur at the hot water faucet due to a reaction between the sacrificial anode and impurities in the water. If this should happen, an alternative anode(s) may be purchased from the supplier that installed this water heater. This will minimize the odor while protecting the tank. Additionally, the water heater should be flushed with appropriate dissolvers to eliminate any bacteria.

IMPORTANT!

Before proceeding, please inspect the water heater and its components for possible damage. **DO NOT** install any damaged components. If damage is evident, please contact the supplier where the water heater was purchased, or the manufacturer listed on the rating plate for replacement parts.

For Installations in the State of California

For California installation this water heater must be braced, anchored, or strapped to avoid falling or moving during an earthquake. See instructions for correct installation procedures. Instructions may be obtained from DSA Headquarters Office, 1102 Q Street, Suite 5100, Sacramento, CA 95811.

Water Heater Capacity

Water Heater Capacity and Increasing Temperature Setpoint:

The water heater temperature setting strongly impacts the amount of usable hot water available for showers and baths.

- Energy consumption/savings and efficiency testing of water heaters is performed according to the Department of Energy (DOE) requirements specified at the date of manufacture.
- Safety regulations require a factory setting no greater than 125°F (52°C) for all new water heaters. Therefore, if your old water heater was set to a hotter temperature than your new water heater with a factory set setpoint of 120°F (49°C), the new water heater may seem to provide lower capacity than your old water heater. This can be corrected by increasing the temperature setpoint.
- If more hot water capacity is desired, increasing the temperature from 120°F to 135°F (49°C to 57°C) will enable the same tank of hot water to last about 25% longer, as less hot water is mixed in at the shower or faucet.
- Increasing the water temperature setpoint may improve the cleaning performance of dishwashers and washing machines.
- The user can adjust the temperature setting to meet their needs. Always read and understand the safety instructions contained in the Installation and Operation Manual before adjusting the temperature setpoint.

Mixing Valves

- Mixing valves for reducing point-of-use water temperature by mixing hot and cold water in branch water lines are commercially available. Contact a licensed plumber or the local plumbing authority for further information.

Specifications

Capacity.....	50/65/80 US gal
Tank Max Working Pressure.....	150 PSI
Water Temperature Set Point Range	100°F-140°F
Electrical.....	240/208 VAC 60 Hz 1-PH
Circuit Breaker.....	25 Amp minimum recommended*
Upper Element Wattage 240/208 VAC	4500/3380
Lower Element Wattage 240/208 VAC	4000/3004
*see branch circuit guide	

Refrigeration System

Compressor.....	500 W
Refrigerant Charge (R134a).....	29.1/30.9 oz (50/80 gal)
Compressor LRA.....	14.0A
Compressor RLA.....	2.56A

About the Control Panel

Displaying Temperature Setpoint

The water heater control will display the temperature setpoint anytime a button on the control is pressed. After 30 seconds of inactivity, the display will go blank. However, the LED indicating the selected operation mode will remain lit. To wake the control at any time to see the temperature setpoint, press any button on the control.

Turning on the Water Heater

There is no power button for this unit. Once the water heater is wired and power is supplied, it will be on. The display will show the current water temperature setting and an LED will illuminate, indicating the current operating mode.

To comply with safety regulations, the controls are factory preset to 120°F (49°C) and Hybrid Mode. It is recommended that the unit be set to Heat Pump (Only) Mode to maximize energy savings. Operating in Hybrid Mode provides a balance of energy savings and hot water use convenience.

Reported energy consumption is based on operating the unit in Hybrid Mode at required Department of Energy (DOE) test conditions. Operating at lower temperature settings or in Heat Pump (Only) Mode will provide even greater energy savings.

To Adjust the Temperature

Follow these steps:

1. Press the UP or DOWN arrow on the control panel keypad to the desired temperature.
2. Press ENTER to accept the new setting.

Note: To change between °F and °C, press and hold MODE.

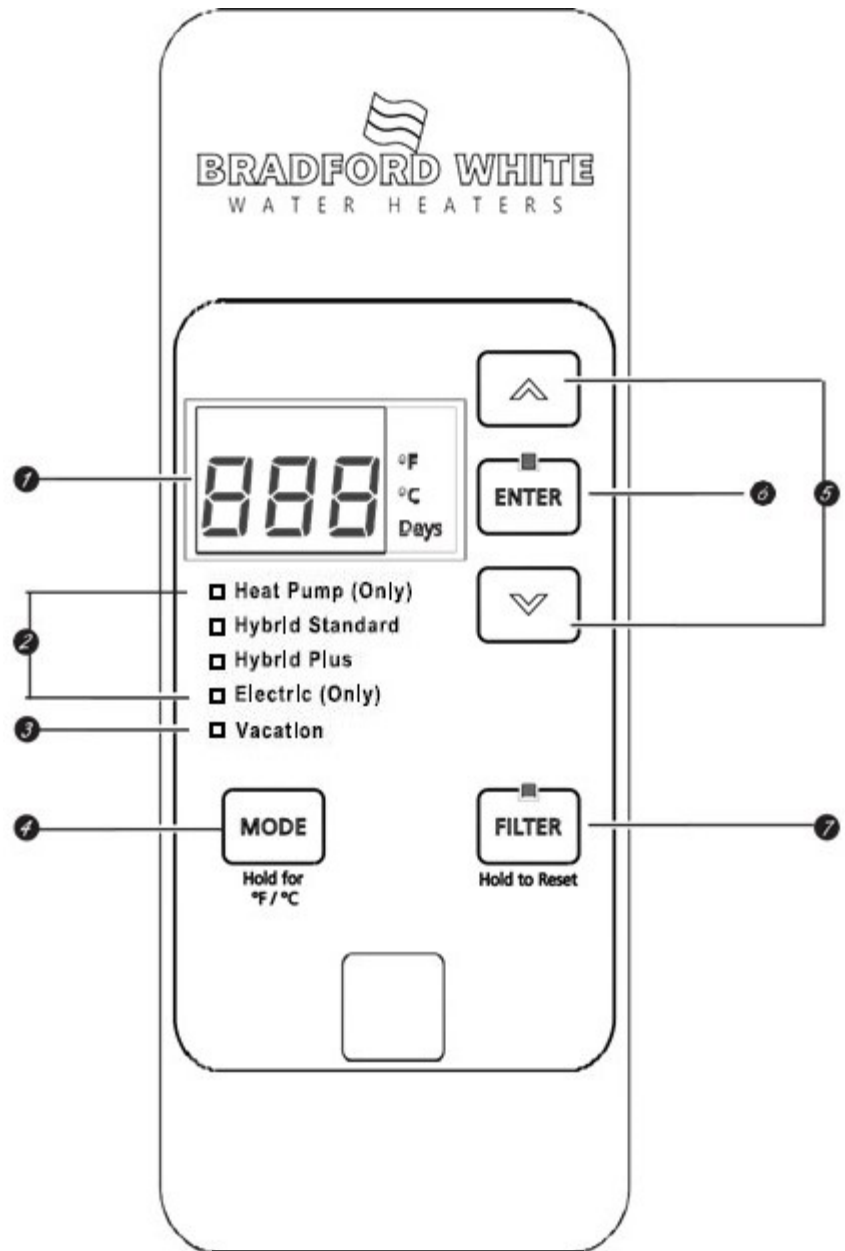

Control Features

- 1 Display**
Displays the current temperature or the number of days for vacation mode. To display setpoint if display has gone blank, press any button.
- 2 Operating Modes**
(see page 6 for description)
- 3 Vacation**
(see page 6 for description)
- 4 Mode Selector**
Press this button to toggle through the various heating modes. Press and hold to switch between °F and °C.
- 5 Arrow Pads**
Use these buttons to manually change the water temperature, or to select days for Vacation Mode.
- 6 Enter Key**
Use this button to confirm temperature setting following adjustment.
- 7 Filter Reset**
The filter is dirty and requires cleaning when the red light is illuminated. Filter is located on top of the water heater. Press the button and hold for 5 seconds to reset filter alarm.

Operational Modes

This water heater defaults to the Hybrid operating mode.

To select available modes listed below:

1. Press the MODE button until the LED next to the desired Operating Mode is illuminated.

In Hybrid Mode, the Electric (Only) Mode LED will flash anytime the heating elements are active, such as during the initial recovery from a large draw. This is normal and does not indicate an operating issue.

Cold Climate Efficiency

The 10 year warranty heat pump water heater is compliant with the Tier 3 Advanced Water Heater Specification, v7.0 (formerly known as the Northern Climate Specification) and may qualify for rebates in some regions. 6yr only Tier 1 compliant). Compliance with the specification does not require a Cold Climate Efficiency (CCE) setting for models produced after 2015 and as a result the CCE setting may not be available on your model. Check with your local utility for available rebates and requirements. A ducting kit is available for use with your heat pump water heater if desired (see www.bradfordwhite.com for ducting kit details). Ducting kits may be installed to achieve directed flow of inlet and outlet air for heat pump operation, or to allow water heater installation in rooms less than 700 ft³ (19.8 m³) or without louvered doors, as specified in the installation instructions.

Heat Pump (Only) Mode—RECOMMENDED FOR MAXIMUM SAVINGS

Heat Pump (Only) is the most energy-efficient mode for this water heater. It takes heat from the surrounding air to heat the water. It takes more time to heat the water in this mode, so it may not be sufficient if you have a high-demand situation, such as a large household or company.

Hybrid Mode

Hybrid Mode combines the energy efficiency of Heat Pump (Only) with the recovery speed and power of the Electric (Only) Mode in most water usage situations. Hybrid Mode will allow the unit to perform like a standard electric water heater while providing significant energy savings.

NOTE: Energy Guide unit performance, energy consumption, and savings are based on non-ducted installations in Hybrid Mode at required Department of Energy (DOE) test conditions. Operating in Heat Pump (Only) Mode may provide greater savings in energy and operating costs than the claimed savings.

Hybrid Plus Mode

This mode may be necessary if the household has a higher-than-average water usage or the water heater is undersized for the household water demands. In this mode, the water heater will use the electric heating elements only when the water demand rate is high. When using the heating elements, the water temperature will recover at a faster rate but it will use more energy to heat it. Unlike Electric (Only) mode, it will use the heating elements only when needed, and use the heat pump when water demand rates are lower.

Electric (Only) Mode

Electric (Only) Mode uses only the upper and lower heating resistance elements to heat the water, stopping the cool air discharge during heat pump operation. It takes less time to heat the water in this mode, but it is the LEAST energy-efficient mode.

Follow these steps to set Electric (Only) Mode:

1. Select Electric (Only) Mode using the MODE button.
2. Input the total days to remain in Electric (Only) Mode using the UP arrow. The default is 3 days, maximum is 99 days.
3. Press ENTER.

At the end of the selected time period, the unit will switch back to the previously selected more energy-efficient mode.

Note: In this mode the green LED light will flash after 48 hours as an indication that the unit is not operating in the most energy efficient mode. The unit will continue to operate in this mode and does not indicate an operating issue.

General Information cont.-

Vacation Mode

This feature is recommended when you will be away from the home for an extended period of time and hot water is not needed. In this mode, the unit will reduce the water temperature setting to 50°F (10°C) and will use the most efficient heating mode to conserve energy while the heater is sitting idle. The unit will automatically resume heating one day before your return, so that hot water will be available.

To set Vacation Mode:

1. Select Vacation by pressing the MODE button.
2. Input the total number of days you will be gone by pressing the UP arrow. The default is 7 days, maximum 199, or the water heater will remain in Vacation Mode indefinitely by selecting “---”.
3. Press ENTER.

For example, if you will be gone 14 days, set Vacation Mode for 14 days using the steps above. The temperature setting will automatically reduce to 50°F (10°C) for 13 days. At the end of the 13th day, the previous operating mode and temperature setting will reset to ensure hot water is available upon your return.

Extended Shutdown Periods

If the water heater is to remain idle for an extended period of time, the power and water to the appliance should be turned OFF and the water heater drained to conserve energy and prevent a buildup of dangerous hydrogen gas.

General Information cont.-

This unit has no power button. The power can only be shut off at the circuit breaker or disconnect switch.

After a long shutdown period, the water heater's operation and controls should be checked by qualified service personnel. Make certain the water heater is completely filled again before placing it in operation.

▲ WARNING

Hydrogen gas can be produced in a hot water system served by this water heater when there has been no usage for a long period of time (generally two weeks or more). **HYDROGEN GAS IS EXTREMELY FLAMMABLE.** To reduce the risk of injury under these conditions, it is recommended that the hot water faucet be opened for several minutes at the kitchen sink before using any electrical appliance connected to the hot water system. If hydrogen is present, there will probably be an unusual sound, such as air escaping through the pipe, as the water begins to flow. There should be **NO** smoking or open flame near the faucet at the time it is open.

For information on Service Mode Functions and Thermistors, reference the mini-manual for this model.

Temperature Adjustment

⚠ CAUTION

Increasing the thermostat setting above the preset temperature may cause severe burns and consume excessive energy. Hotter water increases the risk of scald injury.

This water heater can deliver scalding temperature water at any faucet in the system. Be careful whenever using hot water to avoid scalding injury. Certain appliances, such as dishwashers and automatic clothes washers, may require increased temperature water. By setting the thermostat on this water heater to obtain increased temperature water required by these appliances, you may create the potential for scald injury. To protect against injury, you should install an ASSE approved mixing valve in the water system. This valve will reduce the point of discharge temperature by mixing cold and hot water in branch supply lines. Such valves are available from the manufacturer of this water heater or a local plumbing supplier. Please consult with a plumbing professional.

Safety, energy conservation, and hot water capacity are factors to be considered when selecting the water temperature setting of the water heater. Water temperatures above 125°F can cause severe burns or death from scalding. Be sure to read and follow the warnings outlined on the label pictured below. This label is also located on the water heater near the top of the tank.

The thermostat has been set at the factory to 120°F (49°C) to reduce the risk of scald injury. This is the recommended starting temperature setting, but it can be adjusted to any temperature between 100°F and 140°F (38°C and 60°C).

To adjust the temperature, follow these steps:

1. Press the UP or DOWN arrow on the control panel keypad to the desired temperature.
2. Press ENTER to accept the new setting.

Note: To change between °F and °C, press and hold MODE.

⚠ DANGER

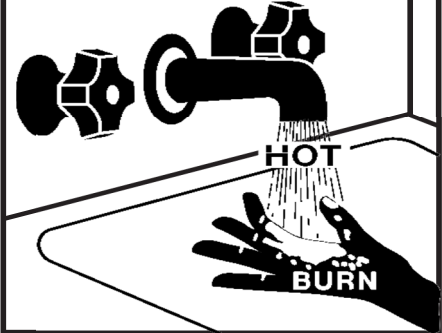

Water temperature over 125°F can cause severe burns instantly or death from scalds.

The electronic temperature control setting usually approximates tap water temperature. However, factors could cause water temperature to reach 160°F regardless of the control setting. Always feel water before bathing and showering.

Children, disabled and elderly are at highest risk of being scalded.

See instruction manual before setting temperature at water heater.

Feel water before bathing or showering.

Temperature limiting valves are available; see manual.

Temperature Adjustment cont.-

APPROXIMATE TIME/TEMPERATURE RELATIONSHIPS IN SCALDS	
120°F (49°C)	More than 5 minutes
125°F (52°C)	1½ to 2 minutes
130°F (54°C)	About 30 seconds
135°F (57°C)	About 10 seconds
140°F (60°C)	Less than 5 seconds
145°F (63°C)	Less than 3 seconds
150°F (66°C)	About 1½ seconds
155°F (68°C)	About 1 second

The chart shown above may be used as a guide in determining the proper water temperature for your home.

Water Heater Temperature Setpoint

The water heater temperature setting strongly impacts the amount of usable hot water available for showers and baths.

- Energy consumption/savings and efficiency testing of water heaters is performed according to the Department of Energy (DOE) requirements specified at the date of manufacture.
- Safety regulations require a factory setting of 120°F to 125°F (49°C to 52°C) maximum for all new water heaters. Therefore, if the water heater is currently set at 130°F (54°C) or above and the new water heater is installed with a factory set setpoint of 120°F (49°C), the new water heater may seem to provide lower capacity than the existing water heater.
- The user can adjust the temperature setting to meet their needs.
- Always read and understand the safety instructions contained in the Installation and Operation Manual before adjusting the temperature setpoint.

Installation Instructions

Local Installation Regulations

This water heater must be installed in accordance with these instructions, local codes, and utility company requirements or, in the absence of local codes, the latest edition of the National Electrical Code. It is available from some local libraries or can be purchased from the National Fire Protection Association, Batterymarch Park, Quincy, MA 02169 as booklet ANSI/NFPA 70.

Power Requirements

Check the markings on the rating plate of the water heater to be certain the power supply corresponds to the water heater requirements. **Note:** 208V installations may experience lower recovery performance.

Locating the Water Heater

⚠ WARNING

Water heaters are heat producing appliances. To avoid damage or injury, there shall be no material stored against the water heater and proper care shall be taken to avoid unnecessary contact (especially by children) with the water heater.

UNDER NO CIRCUMSTANCES SHOULD FLAMMABLE MATERIALS, SUCH AS GASOLINE OR PAINT THINNER BE USED OR STORED IN THE VICINITY OF THIS WATER HEATER OR ANY LOCATION FROM WHICH FUMES COULD REACH THE WATER HEATER.

This water heater **MUST** be installed indoors out of the wind and weather.

The water heater should **NOT** be located in an area where leakage of the tank or connections will result in damage to the area adjacent to it or to lower floors of the structure. Where such areas cannot be avoided, it is recommended that a suitable catch pan, adequately drained, be installed under the water heater.

Installation Instructions cont.-

The location of this water heater is to be installed is of utmost importance. Before installing this water heater, consult the installation section of these instructions. After reading these installation and operating instructions, select a location for the water heater where the floor is level and is easily accessible to a power supply and water connections. The water heater and water lines should be protected from freezing temperatures and highly corrosive atmospheres. Locate the water heater in a clean, dry area. It is recommended that the water heater be located near the center of greatest hot water usage to prevent heat loss through pipes.

Do NOT locate the water heater where water lines could be subjected to freezing temperatures. Locate the water heater so that access panels and drain valves are accessible.

NEVER OPERATE THE WATER HEATER WITHOUT FIRST BEING CERTAIN IT IS FILLED WITH WATER.

Note: Before proceeding with installation, close the main water supply valve.

Water heater corrosion and component failure can be caused by the heating and breakdown of airborne chemical vapors. Examples of some typical compounds that are potentially corrosive are: spray can propellants, cleaning solvents, refrigerator and air conditioning refrigerants, swimming pool chemicals, calcium or sodium chloride, waxes, and process chemicals. These materials are corrosive at very low concentration levels with little or no odor to reveal their presence.

Note: Damage to the water heater caused by exposure to corrosive vapors is not covered by the warranty. Do NOT operate the water heater if exposure has or will occur. Do NOT store any potentially corrosive compounds in the vicinity of the water heater.

This water heater must be located in an area where leakage of the tank or water line connections and the combination temperature and pressure relief valve will not result in damage to the area adjacent to the water heater or to lower floors of the structure. When such locations cannot be avoided, a suitable drain pan must be installed under the water heater. Refer to Catch Pan Installation for more information (pg 12).

This unit is designed for any common indoor installation in a space with at least 700 ft³ (19.8 m³) including: garage, utility room, attic, closet, etc. It can be installed in rooms smaller than 700 ft³ (19.8 m³) with the installation of a louvered door, or two louvered sections (one at the top and one at the bottom of the door or wall for airflow). A ducting kit is also available, for more information see www.BradfordWhite.com. Louvers should have 240 in² (0.15 m²) of open airflow area or greater. Servicing the water heater requires proper installation so that the air filter, covers, trim ring, and front panels can be removed to permit inspection and servicing. Reference installation instructions found in this manual.

The heat pump operating range is 35°F to 120°F (2°C to 49°C). If the ambient temperature is outside of this range, the heat pump will turn off and the electric elements will be used until the ambient temperature returns to within the operating range.

Attic installations require access stairs and solid flooring with no exposed floor joists up to the installation location.

Note: Moving the water heater or other appliances to provide service to the water heater is not covered under warranty.

To comply with NSF requirements this water heater is to be:

- a) Sealed to the floor with sealant, in a smooth and easily cleanable way, or
- b) Installed with an optional leg kit that includes legs and/or extensions that provide a minimum clearance of 6" beneath the water heater.

Note: For California installation this water heater must be braced, anchored, or strapped to avoid falling or moving during an earthquake. See instructions for correct installation procedures.

Instructions may be obtained from DSA Headquarters Office, 1102 Q Street, Suite 5100, Sacramento, CA 95811.

Installation Instructions cont.-

Air Exchange Efficiency

Required and recommended minimum clearances listed in this Installation and Operations Manual are for the optimum performance, efficiency, and serviceability of the water heater.

Installing the water heater in a manner that does not provide sufficient air exchange will result in increased energy consumption. Ensure that the rear of the water heater is open and **not** discharged against a wall. A ducting kit may be required in order to achieve optimum efficiency. Bradford White is not liable or responsible for any additional energy consumption or warranty implications.

Note: If the air temperature in the installed location drops more than 15°F (8°C) during heating, air circulation is insufficient for optimum operation. Utilize the ducting kit to direct cold exhaust air to another location.

Recommended Clearances

NOTE: Installations in a confined space, or installations where the recommended service clearances are not met, will lead to higher power consumption (increased use of resistance heating elements and/or heat pump efficiency reduction).

It is recommended to have a 7" (17.5 cm) clearance between any object and the rear and right side of the water heater in the event service is needed. A minimum 8" (20.3 cm) clearance above the water heater to remove the filter for cleaning and for service access, and clear access to the front of the water heater, is recommended. Installations that require less than 7" (17.5 cm) clearance on the right side or rear of the water heater for earthquake straps are also acceptable (see *Minimum Required Clearances* section below for more information). **In these cases, it is recommended to provide additional clearance on the opposite side of the unit to allow for service access.** The hot and cold water plumbing and electrical connections must not interfere with the removal of the filter.

If a separate ducting kit is purchased (refer to www.bradfordwhite.com for ducting kit part number), additional space is required above and to the rear of the water heater for installation. Consult the ducting kit manual for specific instructions. See www.bradfordwhite.com for details.

The clearances shown are recommended for optimal performance (best possible efficiency) as well as adequate service room. Reducing these clearances may impact the overall performance compared to what is displayed on the water heater. A ducting kit may need to be used – refer to the Service Manual or ducting kit instructions for installation information.

Insufficient air exchange will result in increased energy consumption levels.

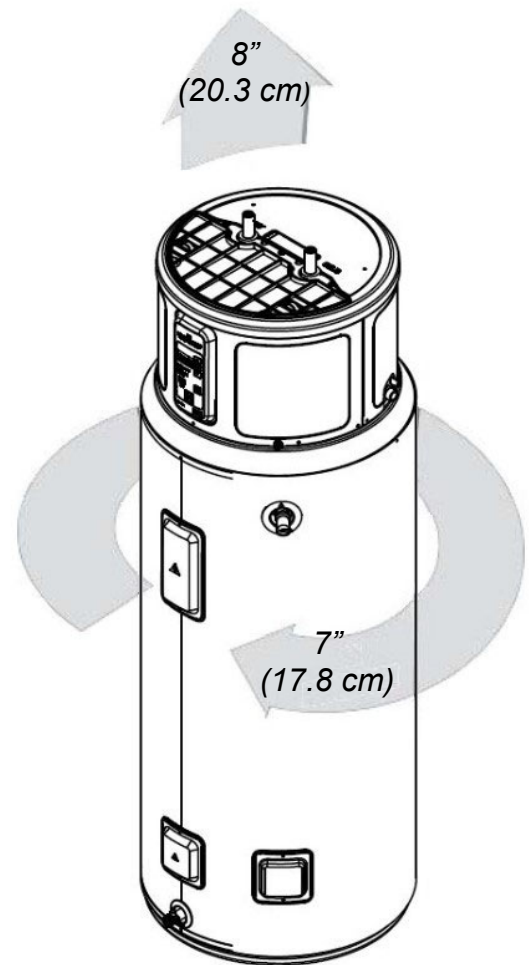

Model appearance may vary

Installation Instructions cont.-

Minimum Required Clearances

NOTE: Installations in a confined space, or installations where the recommended service clearances are not met, will lead to higher power consumption (increased use of resistance heating elements and/or heat pump efficiency reduction).

Corner Installation

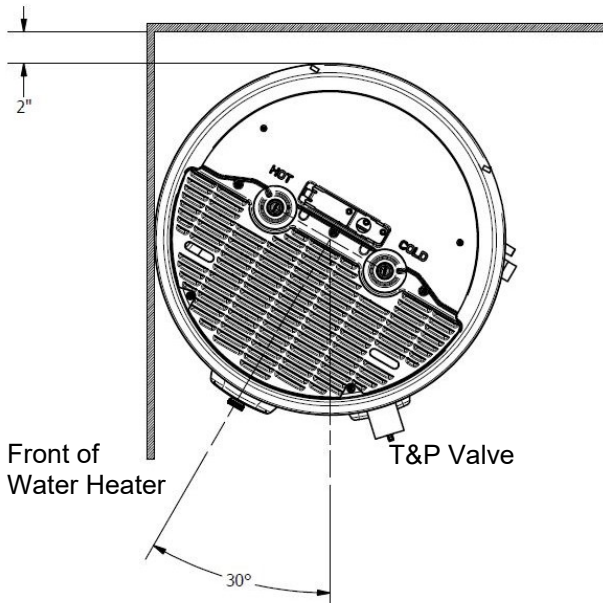

Model RE2H50S

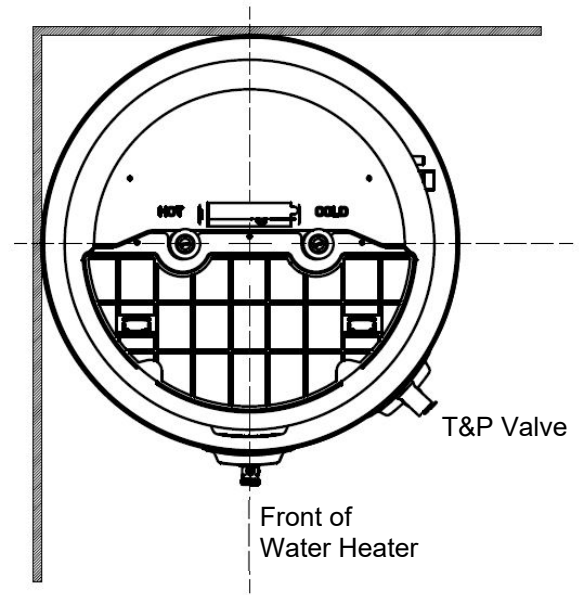

Model RE2H65T & RE2H80T

Alcove Installation

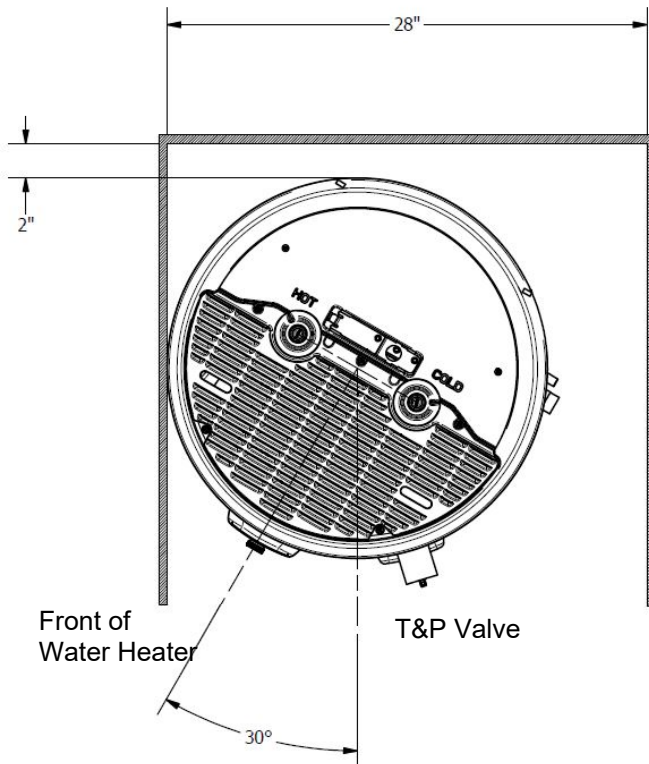

Model RE2H50S

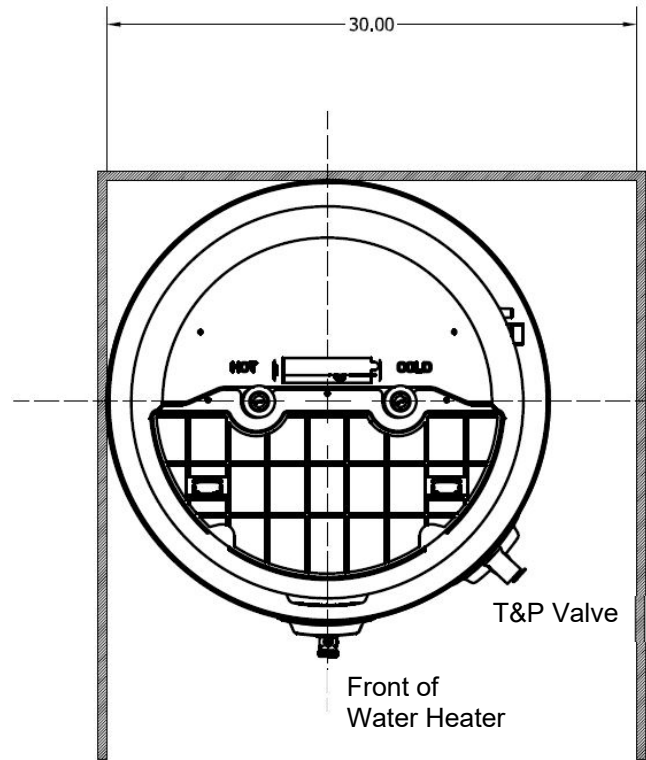

Model RE2H65T & RE2H80T

Installation Instructions cont.-

Condensate Drain Connection

This unit has a condensate drain; therefore, a floor or other drain no higher than 36 in (91.4 cm) above the floor must be available. It must be in close proximity to the water heater to allow for the shortest possible drain line with minimal turns. The drain must meet state and local codes. It is important to install a $\frac{3}{4}$ " FNPT fitting suitable for either rigid or flexible drain line to the primary drain port coming off the side of the unit. Diameter reductions from a $\frac{3}{4}$ " drain line are discouraged.

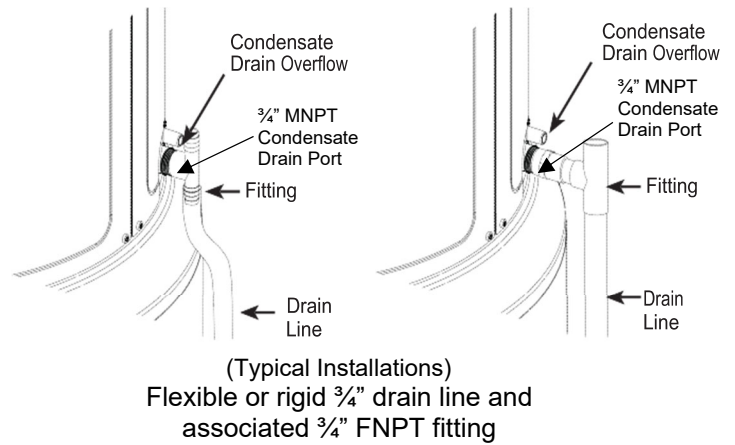

Ensure that the rigid or flexible drain line maintains a downward slope to allow for proper gravity drainage of condensate to the drain and to allow for proper function of the condensate drain blockage sensor. If no drain is available, then a common condensate pump with a capacity no less than 1 gallon/day (3.8 L/day) must be purchased and installed. It is important to route the flexible or rigid drain line so that the discharge water cannot contact live electrical parts or cause water damage.

Catch Pan Installation (if required)

Auxiliary catch pan MUST conform to local codes. Catch pan kits are available from the distributor where the water heater was purchased or any water heater supplier. The catch pan should be at minimum 4 in (10.2 cm) larger than the water heater base diameter. To prevent corrosion and improve drain valve access it is recommended that the water heater be placed on risers inside the catch pan.

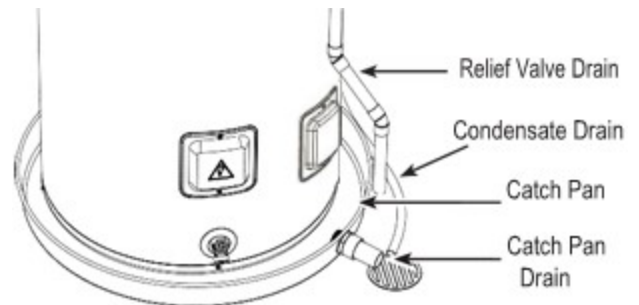

Thermal Expansion

Determine if a check valve exists in the inlet water line. It may have been installed in the cold water line as a separate backflow preventer, or it may be part of a pressure-reducing valve, water meter, or water softener. A check valve located in the cold water inlet line can cause what is referred to as a "closed" water system. A cold water inlet line with no check valve or backflow prevention device is referred to as an "open" water system. As water is heated, it expands in volume and creates an increase in the pressure within the water system. This action is referred to as thermal expansion."

In an "open" water system, expanding water which exceeds the capacity of the water heater flows back into the city main where the pressure is easily dissipated. A "closed" water system prevents the expanding water from flowing back into the main supply line, and the result of thermal expansion can create a rapid and dangerous pressure increase in the water heater and system piping. This rapid pressure increase can quickly reach the safety setting of the relief valve, causing it to operate during each heating cycle.

Thermal expansion, and the resulting rapid and repeated expansion and contraction of components in the water heater and piping system, can cause premature failure of the relief valve, and possibly the heater itself. Replacing the relief valve will NOT correct the problem.

The suggested method of controlling thermal expansion is to install an expansion tank in the cold water line between the water heater and the check valve. The expansion tank is designed with an air cushion built in that compresses as the system pressure increases, thereby relieving the over-pressure condition and eliminating the repeated operation of the relief valve. Other methods of controlling thermal expansion are also available. Contact a qualified service provider for additional information regarding this subject.

Water Supply Connections

Note: BEFORE PROCEEDING WITH THE INSTALLATION, CLOSE THE MAIN WATER SUPPLY VALVE.

After shutting the main water supply valve, open a faucet to relieve the water line pressure to prevent any water from leaking out of pipes while making the water connections to the water heater. After the pressure has been relieved, close the faucet. Refer to the typical installation illustration below for suggested set-up. The HOT and COLD water connections are clearly marked and are 3/4" NPT on all models. When connecting to the inlet/outlet ports, the use of 3/4" female NPT tapered thread fittings with use of thread sealant is recommended. The installation of unions is recommended on the hot and cold water connections so that the water heater may be easily disconnected for servicing if necessary.

Note: Install a shut-off valve in the cold water line near the water heater. This will enable easier service or maintenance of the unit later.

CAUTION

Do NOT apply heat to the HOT or COLD water connections. If sweat connections are used, sweat tubing to adapter before fitting the adapter to the cold water connections on heater. Any heat applied to the hot or cold water connection will permanently damage the internal plastic lining in these ports.

IMPORTANT!

Failure to install and maintain a new, listed 3/4" x 3/4" temperature-pressure relief valve will release the manufacturer from any claim which might result from excessive temperature and pressures.

If this water heater is installed in a closed water supply system, such as the one having a back-flow preventer in the cold water supply, provisions shall be made to control thermal expansion. Do NOT operate this water heater in a closed system without provisions for controlling thermal expansion. Your water supplier or local plumbing inspector should be contacted on how to control this situation.

After installation of water lines, open the main water supply valve and fill the water heater. While the water heater is filling, open several hot water faucets to allow air to escape from the water system. When a steady stream of water flows through the faucets, close them, and check all water connections for possible leaks. NEVER OPERATE THE WATER HEATER WITHOUT FIRST BEING CERTAIN IT IS FILLED WITH WATER.



For protection against excessive temperatures and pressure, install temperature and pressure protective equipment required by local codes, but not less than a combination temperature and pressure relief valve certified by a nationally recognized testing laboratory that maintains periodic inspection of production of listed equipment or materials, as meeting the requirements for Relief Valves and Automatic Gas Shutoff Devices for Hot Water Supply Systems, ANSI Z21.22. The combination temperature and pressure relief valve shall be marked with a maximum set pressure, not to exceed the maximum working pressure of the water heater. The combination temperature and pressure relief valve shall also have an hourly rated temperature steam BTU discharge capacity not less than the hourly input rating of the water heater.

Install the combination temperature and relief valve into the opening provided and marked for this purpose in the water heater.

Note: Some models may already be equipped or supplied with a combination temperature and pressure relief valve. Verify that the combination temperature and pressure relief valve is in compliance with the local codes. If the combination temperature and pressure relief valve does not comply with local codes, replace it with one that does. Follow the installation instructions above on this page.

Install a discharge line so that water discharged from the combination temperature and pressure relief valve will exit within 6 in (15.3 cm) above, or any distance below the structural floor and cannot contact any live electrical part. The discharge line is to be installed to allow for complete drainage of both the temperature and pressure relief valve and the discharge line. The discharge opening must not be subjected to blockage or freezing. Do NOT thread, plug, or cap the discharge line. It is recommended that a minimum of 4 in (10.2 cm) be provided on the side of the water heater for servicing and maintenance of the combination temperature and pressure relief valve.

Do NOT place a valve between the combination temperature and pressure relief valve and the tank.

⚠ WARNING

Hydrogen gas can be produced in a hot water system served by this water heater when there has been no usage for a long period of time (generally two weeks or more). **HYDROGEN GAS IS EXTREMELY FLAMMABLE.** To reduce the risk of injury under these conditions, it is recommended that the hot water faucet be opened for several minutes at the kitchen sink before using any electrical appliance connected to the hot water system. If hydrogen is present, there will probably be an unusual sound, such as air escaping through the pipe, as the water begins to flow. There should be NO smoking or open flame near the faucet at the time it is open.

⚠ DANGER

There is a hot water scald potential if the control water temperature is set too high. Households with small children, disabled, or elderly persons may require a 120°F (49°C) or lower thermostat setting to prevent contact with "HOT" water.

⚠ CAUTION

The cause of the high temperature condition must be investigated by a qualified service technician and corrective action must be taken before placing the water heater in service again.

Safety Controls

The water heater is equipped with a temperature-limiting control (TCO) that is located above the heating element in contact with the tank surface. If for any reason the water temperature becomes excessively high, the temperature-limiting control (TCO) breaks the power circuit to the heating element. Once the control opens, it must be reset manually. Resetting of the temperature limiting controls should be done by a qualified service technician.

To reset the temperature-limiting control:

1. Turn OFF the power to the water heater.
2. Remove the jacket access panel(s) and insulation. The thermostat protective cover should NOT be removed.
3. Press the red RESET button.
4. Replace the insulation and jacket access panel(s) before turning on the power to the water heater.

Typical Installation

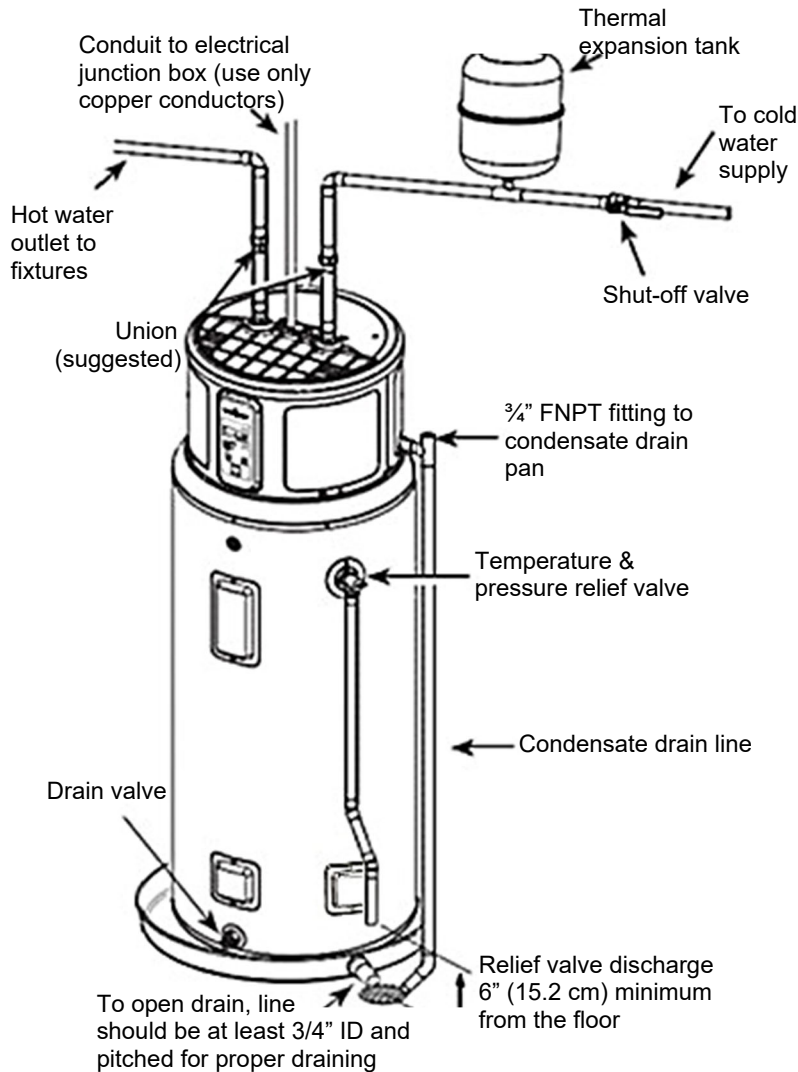

Temperature and Pressure Relief Valve

⚠ WARNING

The pressure rating of the relief valve must not exceed 150 PSI (1.03 kPa) or the maximum working pressure of the water heater as marked on the rating plate.

A new combination temperature and pressure relief valve, complying with the Standard for Relief Valves and Automatic Gas Shut-off Devices for Hot Water Supply Systems, ANSI Z21.22, is supplied and must remain installed in the opening provided and marked for this purpose on the water heater. **NO** valves of any type should be installed between the relief valve and the tank. Local codes shall govern the installation of relief valves. The BTUH rating of the relief valve must **NOT** be less than the input rating of the water heater as indicated on the rating label located on the front of the water heater (1 watt = 3.412 BTUH).

Connect the outlet of the relief valve to a suitable open drain so that the discharge water cannot contact live electrical parts or persons and to eliminate potential water damage.

Piping used should be of a type approved for hot water distribution. The discharge line must be no smaller than the outlet of the valve and must pitch downward from the valve to allow complete drainage (by gravity) of the relief valve and discharge line. The end of the discharge line should not be threaded or concealed and should be protected from freezing. No valve of any type, restriction, or reducer coupling should be installed in the discharge line.

⚠ CAUTION

For protection against excessive temperatures and pressure, install temperature and pressure protective equipment required by local codes, but not less than a combination temperature and pressure relief valve certified by a nationally recognized testing laboratory that maintains periodic inspection of production of listed equipment or materials, as meeting the requirements for Relief Valves and Automatic Gas Shutoff Devices for Hot Water Supply Systems, ANSI Z21.22. The combination temperature and pressure relief valve shall be marked with a maximum set pressure, not to exceed the maximum working pressure of the water heater. The combination temperature and pressure relief valve shall also have an hourly rated temperature steam BTU discharge capacity not less than the hourly input rating of the water heater.

Install the valve into an opening provided and marked for this purpose in the water heater, and orient it or provide tubing so that any discharge from the valve exits only within 6 in (15.2 cm) above, or at any distance below the structural floor, and does **NOT** contact any live electrical part. The discharge opening must not be blocked or reduced in size under any circumstances.

To Fill the Water Heater:

1. Close the water heater drain valve. This water heater utilizes a ball valve; when closing the valve, the stem will spin indefinitely. Confirm it is closed by ensuring the slot on the stem is perpendicular to the valve body.
2. Open the cold water supply shut-off valve.
3. Open several hot water faucets to allow air to escape from the system.
4. When a steady stream of water flows from the faucets, the water heater is filled. Close the faucets and check for water leaks at the water heater drain valve, combination temperature pressure relief valve, and the hot and cold water connections.

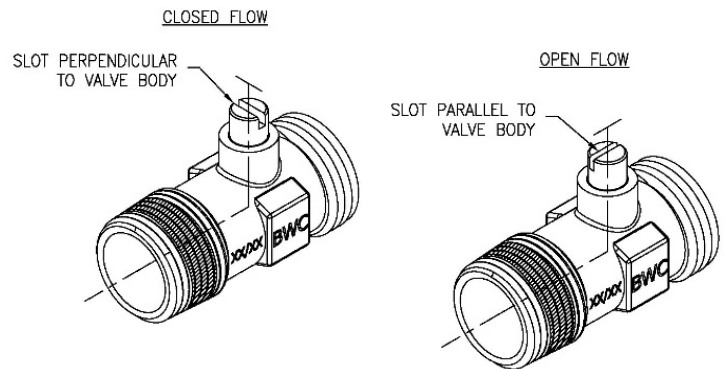

“F11” Fault Code During Installation: If the unit is powered on without a full tank, the error code “F11” will appear. Turn the power OFF, finish filling the tank with water, then turn on the power back ON.

NOTE: The Dry Tank Detection feature on the tank is for the aid of the installer and should **NOT** be used as the primary control to prevent operation with an empty or partially filled tank. Power should **NEVER** be applied to the water heater until the installer has verified that the tank is filled, and all air has been purged from the system.

Electrical Notices: Do **NOT** incorrectly wire electrical connections. 240 VAC or 208 VAC must be applied across L1 and L2 wires. Failure to do so will void the warranty and can result in 120 VAC applied to water heater, which may damage the compressor or other electrical components. If the 4-conductor wire is supplied to the water heater, then cap the neutral, and connect the remaining wires.

NOTE: Regarding Utility Power-Management Devices (sometimes called Peak Load Reduction Switches) – Some power-management switching devices or even some basic timer switches exist that reduce voltage from 240 VAC to 120 VAC during high-electricity-demand periods. These devices must be removed from the circuit providing power to the water heater because of the potential water heater damage noted above. Switching devices which cut power from 240 VAC to 0 VAC on a periodic basis is acceptable.

“bAd line” Fault Code During Installation: If a “bAd line” is shown on the display, the water heater is not receiving the correct voltage as a result of incorrect wiring. To correct this fault, turn the power OFF to the water heater, correct the wiring issue, then turn the power back ON.

Electrical Connections

A separate branch circuit with copper conductors, overcurrent protective device, and suitable disconnect must be provided by a qualified electrician. All wiring must conform to local codes or latest edition of National Electrical Code ANSI/NFPA 70.

The water heater is completely wired to the junction box at the top of the water heater. An opening of 1/2" electrical fitting is provided for field wiring connections. The voltage requirements and wattage load from the water heater are specified on the rating label on the front of the water heater.

The branch circuit wiring should include either:

1. Metallic conduit or metallic sheathed cable approved for use as a grounding conductor and installed with fittings approved for the purpose.
2. Nonmetallic sheathed cable, metallic conduit, or metallic sheathed cable not approved for use as a ground conductor shall include a separate conductor for grounding. It should be attached to the ground terminals of the water heater and the electrical distribution box.

To connect power to the water heater:

1. Turn the power OFF.
2. Remove the screw(s) holding the junction box top cover.
3. Install L1 to L1, L2 to L2, and ground to the **green** ground wire connected to the bottom of the junction box.

Note: Install electric connections according to local codes or latest edition of National Electrical Code ANSI/NFPA 70.

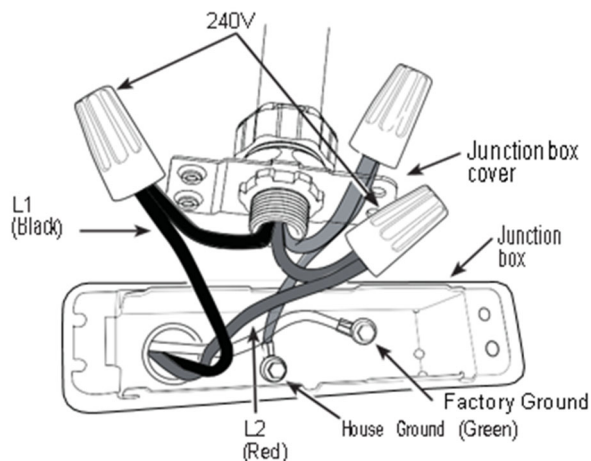

Proper ground connection is essential. The presence of water in the piping and water heater does NOT provide sufficient conduction for a ground. Nonmetallic piping, dielectric unions, flexible connectors, etc., can cause the water heater to be electrically isolated. Do NOT disconnect factory ground.

The manufacturer's warranty does NOT cover any damage or defect caused by installation, attachment or use of any type of energy-saving or other unapproved devices into, onto, or in conjunction with the water heater. The use of unauthorized energy-saving devices may shorten the life of the water heater and may endanger life and property. The manufacturer disclaims any responsibility for such loss or injury resulting from the use of such unauthorized devices.

If local codes require external application of insulation blanket kits, the manufacturer's instructions included with the kit must be carefully followed.

Application of any external insulation, blankets or water pipe insulation to this water heater will require careful attention to the following:

- **Do NOT** cover the temperature and pressure-relief valve.
- **Do NOT** cover access panels to the heating elements.
- **Do NOT** cover the electrical junction box of the water heater.
- **Do NOT** cover the operating or warning labels attached to the water heater or attempt to relocate them on the exterior of the insulation blanket.
- **Do NOT** block the air inlet/outlets in the top covers or rear of the unit.

Note: This guide recommends minimum branch circuit sizing based on the National Electric Code. Refer to wiring diagrams in this manual for field wiring connections.

Branch Circuit Sizing Guide

Total Water Heater Wattage	Recommended Over-Current Protection (fuse or circuit breaker amperage rating)				Total Water Heater Wattage	Copper Wire Size AWG Based on N.E.C. Table 310-16 (167°F/75°C.)			
	208V	240V	277V	480V		208V	240V	277V	480V
3,000	20	20	15	15	3,000	12	12	14	14
4,000	25	25	20	15	4,000	10	10	12	14
4,500	30	25	25	15	4,500	10	10	10	14
5,000	30	30	25	15	5,000	10	10	10	14
5,500	35	30	25	15	5,500	8	10	10	14
6,000	40	35	30	20	6,000	8	8	10	12
8,000	50	45	40	25	8,000	8	8	8	10
9,000	-	50	45	25	9,000	-	8	8	10
10,000	-	-	50	30	10,000	-	-	8	10
11,000	-	-	50	30	11,000	-	-	8	10
12,000	-	-	-	35	12,000	-	-	-	8

Installation Checklist

1. **Tank location:**
- Does room size require a louvered door, ducting kit, or similar ventilation? 10 ft x 10 ft x 7 ft or 700 ft³ (19.8 m³), or 240 in² (0.15 m²) open air-flow area needed.
 - 7 in (17.5 cm) clearance at the rear of the unit and at least 7 in (17.5 cm) clearance around the sides of the unit. 6 in (15.2 cm) clearance for earthquake strap installations, with additional clearance on the opposite side of the unit).
 - **Front** of unit is free and clear.
 - Is the water heater level? If no, add shims under the base of the unit to ensure proper function of sensors.
2. Verify Air Filter is installed (located in packaging).
3. **Plumbing connections:**
- Ensure that air filter removal is not prevented.
 - Check for leaks after filling the tank with water, when water is or isn't flowing.
4. **Condensate lines are in place:**
- Main flexible or rigid drain line must be installed and directed to a drain or condensate pump. Reducer fittings are **not** recommended.
5. **Temperature and pressure-relief valve** is working and drain line completed per local code.
6. **Electrical:**
- Verify 208/240 VAC to L1 and L2 at tank.
 - Ensure that the electrical connection does **not** prevent air filter removal.
7. Verify that the control panel displays 120°F (49°C) in Hybrid Mode. Assist user in how to adjust temperature and modes (see "Water Temperature Adjustment" section).

Electrical Connections cont.-

What to Expect for “Normal Startup” in Hybrid Mode

After the unit has been installed, with all electrical and water connections secure and checked, then the unit should be filled with water (vent tank by opening a hot water faucet somewhere in home to allow tank to fully fill with water). Once the tank is full and power is energized, you may experience the following:

Elapsed Time	Water Heater Actions	Comments
0 to 2 minutes	Unit will go through self-check and display countdown. Fan will turn on after 1 minute.	This 2-minute off-time prevents compressor damage. A clicking noise may be heard during startup.
2 to 22 minutes	Compressor turns on. Fan continues to run.	This 20-minute period is used to ensure the tank is full of water (dry-fire prevention algorithm).
22 minutes and beyond	Compressor turns off (fan will run for 20 minutes after any compressor operation). Normal heating operation resumes.	The water heater is operating in Hybrid mode. Quickly provides initial amount of hot water with heating elements, then switches to efficient heat pump for majority of heating.

Note: The heat pump operating range is 35°F to 120°F (2°C to 49°C). If the ambient temperature is outside of this range, the heat pump will turn off and the electric elements will be used until the ambient temperature returns to within the operating range. During commissioning, a self-test countdown number will be displayed indicating the time remaining before the unit begins normal operation.

General Operation

Before closing the switch to allow electric current to flow to the water heater, make certain that the water heater is full of water and that the cold water inlet valve is open. Complete failure of the heating element(s) will result if they are not totally immersed in water at all times. Failure of the element(s) due to dry-firing is NOT covered by warranty.

When the switch is closed, the operation of this electric water heater is automatic. The thermostats are preset to the “HOT” setting to provide a water temperature of approximately 120°F (49°C) to reduce the risk of scald injury.

CAUTION

Scalding may occur within 5 seconds at a temperature setting of 140°F (60°C).

Care must be taken whenever using hot water to avoid scalding injury. Certain appliances require high temperature hot water (such as dishwashers and automatic clothes washers).

To Fill the Water Heater:

1. Close the water heater drain valve. This water heater utilizes a ball valve; when closing the valve, the stem will spin indefinitely. Confirm it is closed by ensuring the slot on the stem is perpendicular to the valve body.
2. Open the cold water supply shut-off valve.
3. Open several hot water faucets to allow air to escape from the system.
4. When a steady stream of water flows from the faucets, the water heater is filled. Close the faucets and check for water leaks at the water heater drain valve, combination temperature pressure relief valve, and the hot and cold water connections.

To Drain the Water Heater:

Should it become necessary to completely drain the water heater, make sure you follow the steps below.

1. Turn OFF the power to the unit. The electric heating elements will become damaged if operated without water.
2. Attach a hose to the drain valve located at the bottom of the unit and direct the hose to a drain.
3. Turn OFF the cold water supply.
4. Admit air to the tank by opening a hot water faucet or lifting the handle on the relief valve.
5. Open the drain valve with a flat screwdriver.

General Operation cont.-

Bradford White Connect™

For installation instructions on the Bradford White Connect™ adapter, please see the Installation and Operations Manual supplied in the Bradford White Connect kit.

To download the Bradford White Connect™ app, visit the app store of your mobile device.

For more information, visit www.bradfordwhite.com/connect or email iot.app@bradfordwhite.com

Electric Grid Connectivity (Optional)

To participate in a utility energy management program, an ASSE approved mixing valve must be installed in the water system. This valve will reduce point of discharge temperature by mixing cold and hot water in branch supply lines. Please consult with a plumbing professional for an appropriately specified ASSE thermostatic mixing valve.

Your Bradford White Connect™ Adapter is equipped with a CTA-2045 (DC) port, used for energy management by the electric grid. Insert a compatible DC Universal Communications Module (UCM), supplied by your electric utility provider, into the CTA-2045 port on the Adapter. Follow the UCM instructions provided by the utility company to connect the UCM to the utility grid. Further management of utility programs, including enabling or disabling, can be done in the Water Heater Settings of the Bradford White Connect™ App.

For more details about participation or eligibility, contact your electric utility provider.

Maintenance

IMPORTANT!

The water heater should be inspected annually at minimum by a qualified service technician for damaged components. Do **NOT** operate this water heater if any part is found damaged.

Shut off the electric power whenever the water supply to the water heater is off. Shut off the electric power and water supply, drain the water heater completely to prevent freezing whenever the building is left unoccupied during the cold winter months. In order to ensure efficient operation and long tank life, drain the water heater at least once a month through the drain valve until the water runs clear. Failure to do this may result in noisy operation and lime and sediment buildup in the bottom of the tank. Check the temperature pressure relief valve to ensure that the valve has not become encrusted with lime. Lift the lever at the top of the valve several times until the valve seats properly without leaking and operates freely.

⚠ WARNING

When lifting the temperature pressure relief valve lever, hot water will be released under pressure. Be certain that any released water does not result in bodily injury or property damage. The magnesium anode rod should be inspected periodically and replaced when necessary to prolong tank life.

Note: If the temperature and pressure-relief valve on the hot water heater discharges periodically, this may be due to thermal expansion in a closed water system. Contact the water supplier or your plumbing contractor on how to correct this. Do **not** plug the relief valve outlet.

Properly maintained, your water heater will provide years of dependable trouble-free service. It is suggested that the following yearly preventive maintenance program be established.

1. Inspect Temperature & Pressure Relief Valve
 - a. Once a year, it is recommended to lift and release the lever handle on the temperature and pressure-relief valve, located on the front-right side of the water heater, to make certain the valve operates freely. Allow several gallons to flush through the discharge line to an open drain.
2. Inspect heating elements, TCO, and wiring to each.
 - a. Once a year, it is recommended to inspect the heating elements, TCO, and wiring to each. Inspection should be completed by service personnel qualified in electrical appliance repair.
 - b. Most electrical appliances, even when new, make some sound when in operation. If the hissing or singing sound level increases excessively, the electric heating element may require cleaning. Contact a qualified installer or plumber for inspection.
3. Drain and flush the water heater tank.
4. Clean the air filter.
5. Clear the condensate drain pan the drain lines.
6. Anode rod(s) must be removed and inspected.

⚠ CAUTION

For your safety, do **NOT** attempt to repair the water heater or any of its parts. Refer any repairs to a qualified service technician.

Maintenance cont.-

Draining and Flushing the Water Heater



Shut **OFF** power to the water heater before draining water to avoid risk of shock.



Before manually operating the relief valve, make certain no one will be exposed to the danger of coming in contact with the hot water released by the valve. The water may be hot enough to scald person(s) nearby. The water should be released into a suitable drain to prevent injury or damage.

A water heater's tank can act as a settling basin for solids suspended in the water. It is therefore not uncommon for hard water deposits to accumulate in the bottom of the tank. To clean the tank of these deposits, it is recommended to drain and flush the water heater tank once a year.

Draining the Water Heater

1. Turn OFF the power to the unit. The electric heating elements will become damaged if operated without water.
2. Attach a hose to the drain valve located at the bottom of the unit and direct the hose to a drain.
3. Turn OFF the cold water supply.
4. Admit air to the tank by opening a hot water faucet or lifting the handle on the relief valve.
5. Open the drain valve with a flat screwdriver.

Flushing the Tank

Flushing should be done with an empty tank to promote additional removal of sediment.

1. Follow the steps above to drain the water heater.
2. Once the water heater is empty, with the drain valve open and hose attached to the drain valve, turn on the cold water supply.
3. Allow several gallons to flush through the drain valve and hose to an open drain.
4. Turn OFF the water supply and allow any water remaining in the tank to drain.
5. Repeat steps 3 and 4 until the water runs clear.
6. Close the drain valve and fill the tank **BEFORE** returning power to the unit. The tank is full when water runs out of a nearby open hot water faucet.

Use a flat screwdriver to turn valve

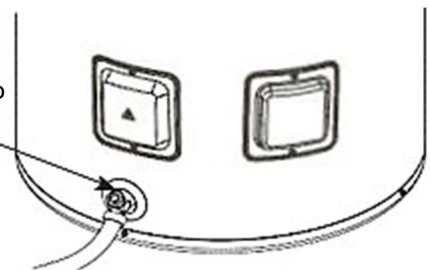

Cleaning the Filter

In the Hybrid and Heat Pump (Only) modes, the water heater pulls air through the filter and out the back of the unit. The filter is in place to protect the evaporator from dirt and dust.

A clean air filter is important to get the highest efficiency. Occasionally this filter will need to be cleaned. When the filter requires cleaning, the **red** light above the FILTER button will illuminate and an alarm will sound.

IMPORTANT!

Filter must be cleaned when the alarm is displayed. A dirty filter will make the system work harder and result in a reduction of efficiency and cause possible damage to the system. In order to get the best energy efficiency available, make sure the filter is clean.

Note: If the filter gets too dirty, the unit will automatically switch to Electric (Only) Mode and energy savings will be lost.

Maintenance cont.-

To clean the filter:

1. Leave the power ON.
2. Remove the filter from the top of the unit.
3. Squeeze the two tabs and lift to remove the air filter. Once it has been removed, the filter can be vacuumed or wiped clean with a damp cloth or rinsed with warm water.
4. Once the filter has been cleaned and dried, it can be replaced by aligning it into the slots into the top of the unit and pushing it down into place.
5. After the clean filter has been reinstalled, press and hold the FILTER button to reset the alarm.

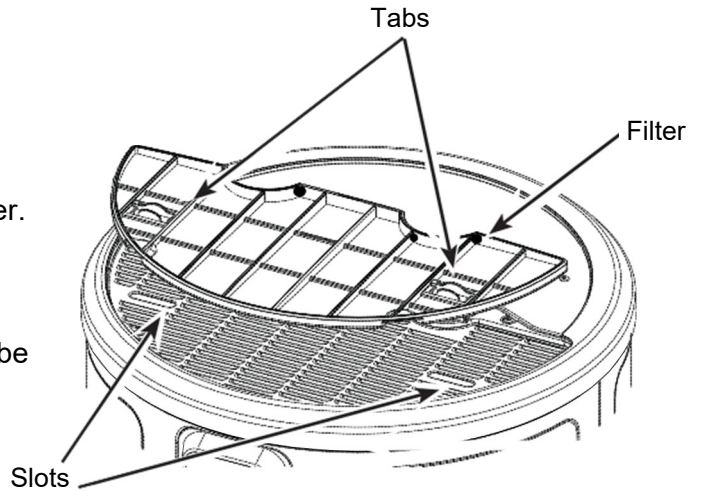

The unit will automatically revert to the previously selected operating mode. If a heating cycle is active when the filter alarm is reset, it will continue in Electric (Only) mode to finish the cycle, then automatically revert to the previously selected mode.

Note: If the dirty filter alarm returns within a few days after cleaning and resetting, it may be an indication of a refrigerant leak. Further diagnosis by a service technician is necessary.

Clearing the Condensation Drain Tube

The main drain is intended to remove all condensate. If it is clogged, the heat pump will stop operating, the display will show F20, and an alarm will sound. Press any button to silence the alarm, then clear the condensate drain by removing any drain lines and connections and clearing debris. Reattach drain lines and connections, then allow the water heater to run.

The water heater will continue to produce hot water using the backup resistance heating elements until the condensate drain has been cleared and is able to drain properly. Once the drain has been cleared, the unit will then be able to operate the heat pump again.

Periodically inspect the drain lines and clear any debris that may have collected in the lines.

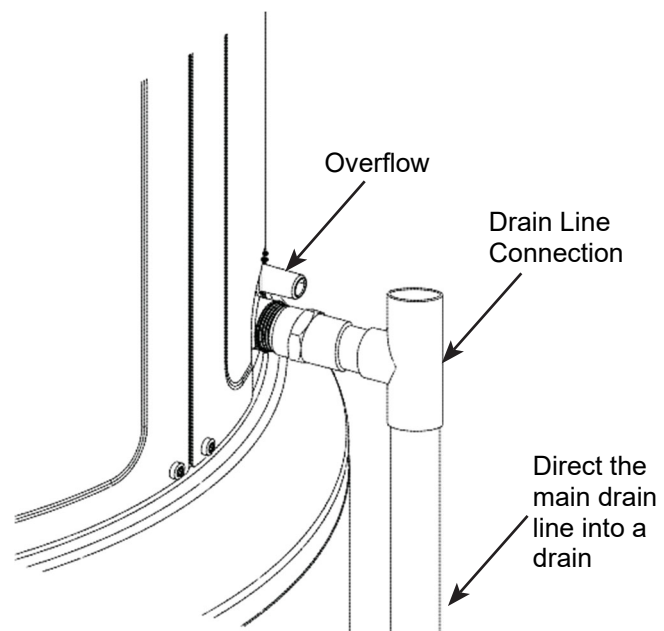

Anode Rod

Anode rods are designed and installed to protect and extend the life of residential water storage tanks. The anode rod must be removed from the water heater's tank and inspected annually and replaced when more than 6 in (15.2 cm) of core wire is exposed at either end of the rod.* Artificially softened water will cause the anode rod to consume more rapidly.

Failure to replace the anode rod when consumed risks voiding the warranty for the tank. Warranty coverage for all other components remains intact and is unaffected by this maintenance requirement. The replacement anode rod, and the inspection for consumption are not covered by warranty.

Due to shock hazard and to prevent accidental water leaks, this inspection should be done by a qualified servicer or plumber and requires that the electric power and cold water supply be turned OFF before servicing the anode rod.

Do **NOT** remove the anode rod from the water heater's tank except for inspection and/or replacement, as operation with the anode rod removed will shorten the life of the glass-lined tank and will void warranty coverage.

Anode Rod Maintenance and Service

⚠ CAUTION

This information is intended to use by individuals possessing adequate background of electrical, electronic and mechanical experience. Any attempt to repair a major appliance may result in personal injury and property damage. The manufacturer or seller cannot be responsible for the interpretation of this information, nor can it assume any liability in connection with its use.

To Service the Anode Rod:

1. Disconnect power, shut OFF the water supply, and partially drain one or two gallons from the water heater through the lower drain valve.
2. Remove the filter, trim ring, and front top cover as shown in **Illustration A**.
3. Reinstall the trim ring and place a protective layer of tape on sheet metal edges as shown in **Illustration B**.
4. If present, remove insulation to uncover the anode rod as shown in **Illustration C**.
5. Using a 1 1/16" socket and extension, unscrew the anode rod, then lift out to inspect as shown in **Illustration D**.
6. To install the anode rod, seal the threads with soft set sealant, thread into the port using the torque wrench tighten to 50± 5ft-lbs of torque.
7. Turn water supply ON, open a tap to remove any air in the plumbing system, inspect for leaks, then reassemble the unit in reverse order as shown in **Illustration A** and turn the power ON.

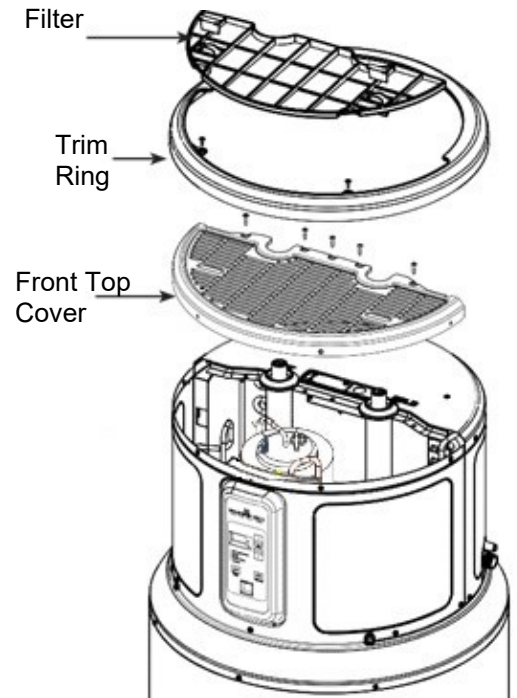

Illustration A

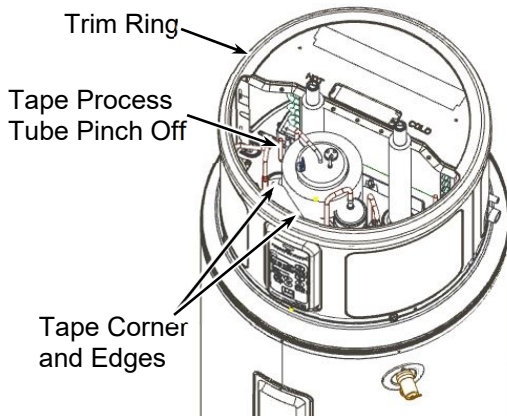

Illustration B

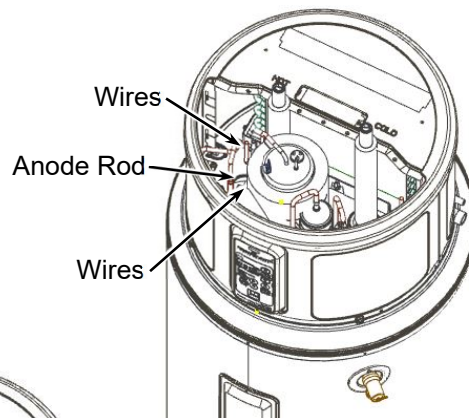

Illustration C

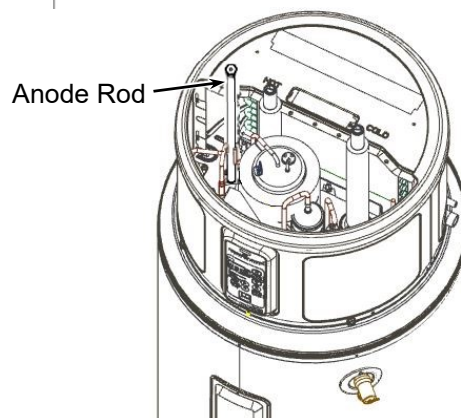

Illustration D

Maintenance cont.-

Contact your local plumbing supplier or plumbing professional for replacement parts or contact the company at the address displayed on the rating plater of the water heater.

For faster and better service, please provide the part name, model, and serial number(s) of the water heater(s) when ordering parts.

READ THE WARRANTY FOR A FULL EXPLANATION OF THE LENGTH OF TIME THAT PARTS AND THE WATER HEATER ARE WARRANTED.

Manufactured under one or more of the following U.S. Patents: 5,277,171; 5,341,770; 5,372,185; 5,485,879; 5,574,822; 5,596,952; 5,660,165; 5,682,666; 5,761,379; 5,943,984; 5,954,492; 5,988,117; 6,056,542; 6,142,216; 6,442,178; 6,684,821; 6,935,280; 7,063,132; 7,063,133; 7,007,748; 7,270,087; 7,334,419; 7,337,517; 7,409,925; 7,458,341; 7,559,293; 7,621,238; 7,634,976; 7,650,859; 7,665,210; 7,665,211; 7,699,026; 7,866,168; 7,900,589; 7,971,560; 7,992,526 8,082,888; 8,146,772; Other U.S. and Foreign patent applications pending. Current Canadian Patents: 2,092,105; 2,107,012; 2,108,186; 2,112,515; 2,143,031; 2,239,007; 2,262,174; 2,314,845; 2,409,271; 2,476,685; 2,504,824; 2,548,958

Refer to the parts list on www.bradfordwhite.com for a complete parts listing and expanded views of the models covered in this manual.

Complete the following information and retain for future reference:

Model No: _____

Serial No: _____

Service Phone

Days: _____ Nights: _____

Address: _____

Supplier: _____

Supplier Phone No.: _____

Frequently Asked Questions

Filter:

Q: Why is there a filter?

A: In Hybrid and Heat Pump (Only) the unit moves air through the system. The filter protects the unit from dirt and debris. A clean air filter improves efficiency.

Q: How do I clean the filter?

A: Leave the power ON and remove filter from top of unit. The filter can be vacuumed clean or rinsed with warm water. Once cleaned, reset the alarm by pressing and holding the FILTER button. A dirty filter will reduce water heater efficiency.

Modes:

Q: What is "Heat Pump (Only)"?

A: Heat Pump (Only) is the **most** efficient mode. It takes heat from the air to heat water, cooling the surrounding air. It has slower recovery but is the **most** efficient mode.

Q: What is "Hybrid"?

A: Hybrid Mode combines benefits of Heat Pump (Only) with the speed and power of Standard Electric. This provides great performance with less energy.

Q: What is "Vacation" Mode?

A: If you are gone for an extended period, this mode lowers the water temperature to reduce energy used. Unit will switch to the previous mode one day before you get back.

Q: What is "Electric (Only)"?

A: Electric (Only) mode uses only the resistance heaters to heat the water. This gives faster hot water recovery than Hybrid mode but uses more energy. This mode operates without the fan, stopping the cool air normally discharged during heat pump operation.

Q: Why does the Electric (Only) green LED flash?

A: In this mode, the green LED light will flash after 48 hours as an indication that the unit is NOT operating in the most energy efficient mode.

Operation:

Q: Why can I hear the unit run?

A: In the most energy-efficient models, Heat Pump (Only) and Hybrid, the method used to heat the water used a fan that can be heard while running.

Q: The heat pump is not running its normal length of time. What causes this?

A: Under some conditions, the water heater will operate using the electric elements instead of the heat pump to protect your unit and ensure hot water is available to you. These conditions include extreme cold ambient temperature (<35°F), extreme hot ambient temperatures (>120°F), or very low voltage conditions. The unit will return to normal operation when conditions permit.

Q: Why does the water heater display a number other than the temperature setpoint at startup or following a power loss?

A: During commissioning, a self-test countdown number will be displayed indicating the time remaining before the unit begins normal operation. It is heating water during this time.

Q: Why isn't the temperature setting always displayed on the temperature setpoint at startup or following a power loss?

A: The control will only display the temperature setting when a heat source is called for by the system and will turn off when the heating elements and heat pump are not running. Pressing any button will wake the control and display the temperature setpoint. The display screen will go blank after a period of inactivity in order to conserve energy.

Q: Why is one of the operating mode LEDs flashing?

A: In Hybrid Mode, the Electric (Only) Mode LED will flash anytime the heating elements are active, such as during the initial recovery from a large draw. In Electric (Only) Mode, the operating mode LED will flash after 48 hours as an indication that the unit is not operating in the most energy efficient mode. These are both normal conditions and do **NOT** indicate an operating issue.

Fault Codes

Note: It's important to note that fault codes should only be used to help identify components which require testing. *Never replace a part based solely on a fault code.* The control can generate a false fault if the right conditions exist. Contact a certified technician to assess and repair the water heater based on the fault codes.

Fault Code Displayed	Fault Counts Before Code Displayed	Condition
FC	10	Control checks to ensure evaporator is free of frost. Continuously verifies that T3a sensor (evaporator inlet temperature) is greater than 20°F after 30 minutes of run time.
Fd	10	Control checks to ensure evaporator superheat* is OK (controlled by EEV). Continuously verifies the temperature difference between T3a sensor (evaporator inlet temperature) and T3b sensor (evaporator outlet temperature) is greater than 5°F after 30 minutes of run time. Control also verifies that T3a is greater than 10°F less than T5 ambient sensor.
FE	10	Control checks to ensure the compressor discharge temperature never exceeds 240°F. Continuously verifies that T4 sensor (compressor outlet temperature) is less than 240°F every minute of run time.
FF	10	Control checks to ensure the EEV is operating properly and valve rotation is within range.
FG	10	Control checks to ensure ambient temperature is within an acceptable range before starting heat pump. Heat pump operating range is 35°F < [T5 ambient] < 120°F. If ambient temperature (as viewed by T5 sensor) is outside of this range, the water heater will switch to Electric/Standard Mode for that heating cycle only. NO fault code is shown on the display.
FI*	10	Control checks to ensure evaporator superheat is <20°F AND the EEV position is <450 after 30 minutes of run time. If outside these limits, this provides an early indication of a refrigerant leak. (Note: Target superheat is generally 10°F, and EEV generally operates at a position much lower than 450).
FJ	10	Control checks to ensure that the AC current draw is ≤ 20.5A while the compressor and lower heating element are both enabled. If current draw is > 20.5A, the compressor will be disabled.
FL	10	Control checks to ensure that T3 and T3b evaporator inlet and outlet temperatures are within 2.5°F of the T5 ambient temperature 20 minutes after defrost begins.
F2	1	T2 tank temperature sensor failure. Just before compressor starts, control checks T2 sensor is within 30°F - 170°F temperature range.
F3	10	Compressor failure. Control energizes compressor, but current sensor detects no current flow.
F4	10	Fan failure.
F5	10	T3a sensor (evaporator inlet temperature) failure. The control detects the thermistor output is at or nearly shorted or open circuit.
F6	10	T3b sensor (evaporator outlet temperature) failure. The control detects the thermistor output is at or nearly shorted or open circuit.
F7	10	T4 sensor (compressor outlet) failure. The control detects the thermistor output is at or nearly shorted or open circuit.

*On some models

Fault codes cont.-

Fault Code Displayed	Fault Counts Before Code Displayed	Condition
F8	10	T5 sensor (ambient temperature) failure. The control detects the thermistor output is at or nearly shorted or open circuit.
F9	10	Lower heating element failure. Control energizes lower element, but current sensor detects no current flow.
F10	10	Upper heating element failure. Control energizes upper element, but current sensor detects no current flow.
F11	1	Dry tank fault. This test is run within the first 22 minutes after the water heater has powered on (The compressor is engaged for 20 minutes after a 2 minute wait for the system to allow the high and low side pressures to equalize). The tank temperature, T2, is read and verified it has not risen more than 5°F. If it has, this indicates there is not enough water in the tank for water heater operation. After 1 failed dry tank test, "F11" is displayed. After 5 failed tests, an audible alarm will sound.
bAd linE F12	1	The voltage is too low at power-up. The control monitors the input line voltage one minute after power-up, and if the voltage is below 155 VAC, the fault code will be displayed.
F13	1	Stuck key fault. This indicates there is a button on the front panel that is stuck down. This button is inoperable. Other buttons work normally. If the button becomes free, the fault code will clear by itself.
Dirty Filter (F14)	5	Filter LED is on, and audible alarm is sounding. Filter is too dirty to enable proper function of water heater. Number of "Dirty Filter" counts are stored in the "F14" code and can be monitored via the control when it is place in Diagnostics Mode. The evaporator is operating at a colder temperature than the ambient temperature as measure by T5.
F15	10	DataFlash fault. The microcontroller has detected a problem in the DataFlash (permanent memory storage).
F16*	1	Anode Depleted. Anode LED is on, and the audible alarm is sounding. The control has calculated that the anode rod has been mostly consumed, or the time in operation has exceeded the replacement timeline threshold.
F17*	1	Anode Depletion miswire condition or shorted to ground. The control has detected that the anode circuit has a corrosion current signal $\leq 0.25\text{mA}$.
F18	10	Current transformer miswired. F3, F9, and F10 fault codes have all occurred during the same heating cycle.
F19	10	Low line voltage.
F20	10	Condensate drain port blocked. Water heater will only operate in standard/electric mode until the drain port is cleared and the sensor is no longer in contact with water.
F21	1	Application Update Failure. A problem occurred while updating the control application.
F22	1	Parametric Data Update Failure. A problem occurred while updating parametric data.
F23	10	Micro A/D Failure. The control has detected a microcontroller input port has failed.
F24	1	T1 tank temperature sensor failure. Just before compressor starts, control checks T1 sensor is within 30°F - 170°F temperature range.

*On some models

Notes