

<b>DOCKETED</b>	
<b>Docket Number:</b>	17-MISC-01
<b>Project Title:</b>	California Offshore Renewable Energy
<b>TN #:</b>	247365
<b>Document Title:</b>	Energinet Presentation for November 10, 2022 AB 525 Offshore Wind Workshop on Transmission
<b>Description:</b>	ENERGINET – TRANSMISSION AND FUTURE OSW CONNECTIONS, Peter Markussen
<b>Filer:</b>	Rhetta DeMesa
<b>Organization:</b>	California Energy Commission
<b>Submitter Role:</b>	Commission Staff
<b>Submission Date:</b>	11/10/2022 8:07:52 AM
<b>Docketed Date:</b>	11/10/2022

# ENERGINET – TRANSMISSION AND FUTURE OSW CONNECTIONS

November 2022

*Peter Markussen, Senior director, Senior Director, Energinet*  
([pmr@energinet.dk](mailto:pmr@energinet.dk))

# ENERGINET

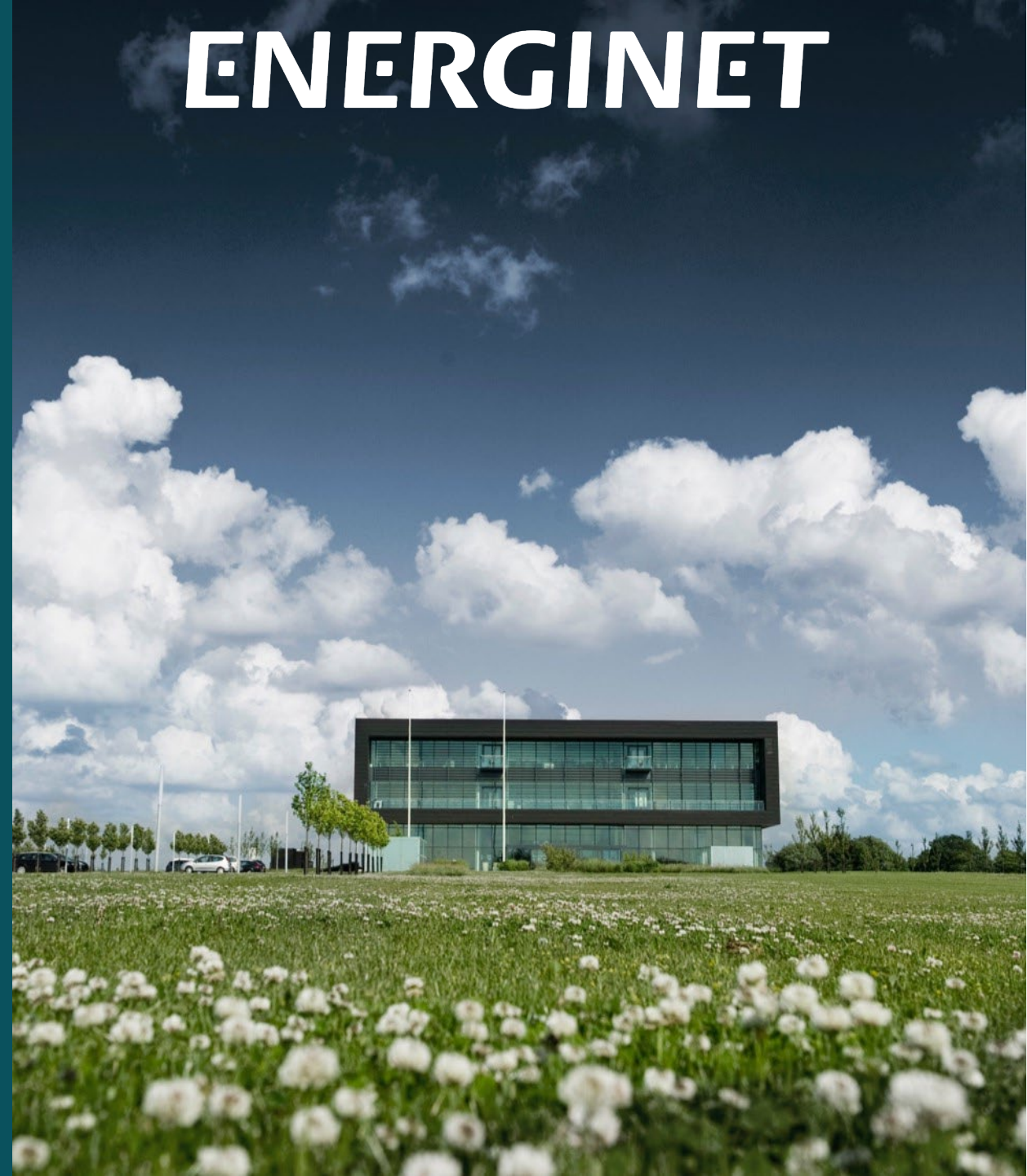

# ENERGINET

## THE ENERGY BACKBONE

We operate and develop the transmission grids and gas pipelines in Denmark.

## ENSURE BALANCE

We have the day-to-day and long-term responsibility for the overall electricity and gas system in Denmark.

## WORKING FOR THE SOCIETY

Owned by the Danish Ministry of Climate, Energy and Utilities we safeguard society's interests as we move to a 100% green energy system.

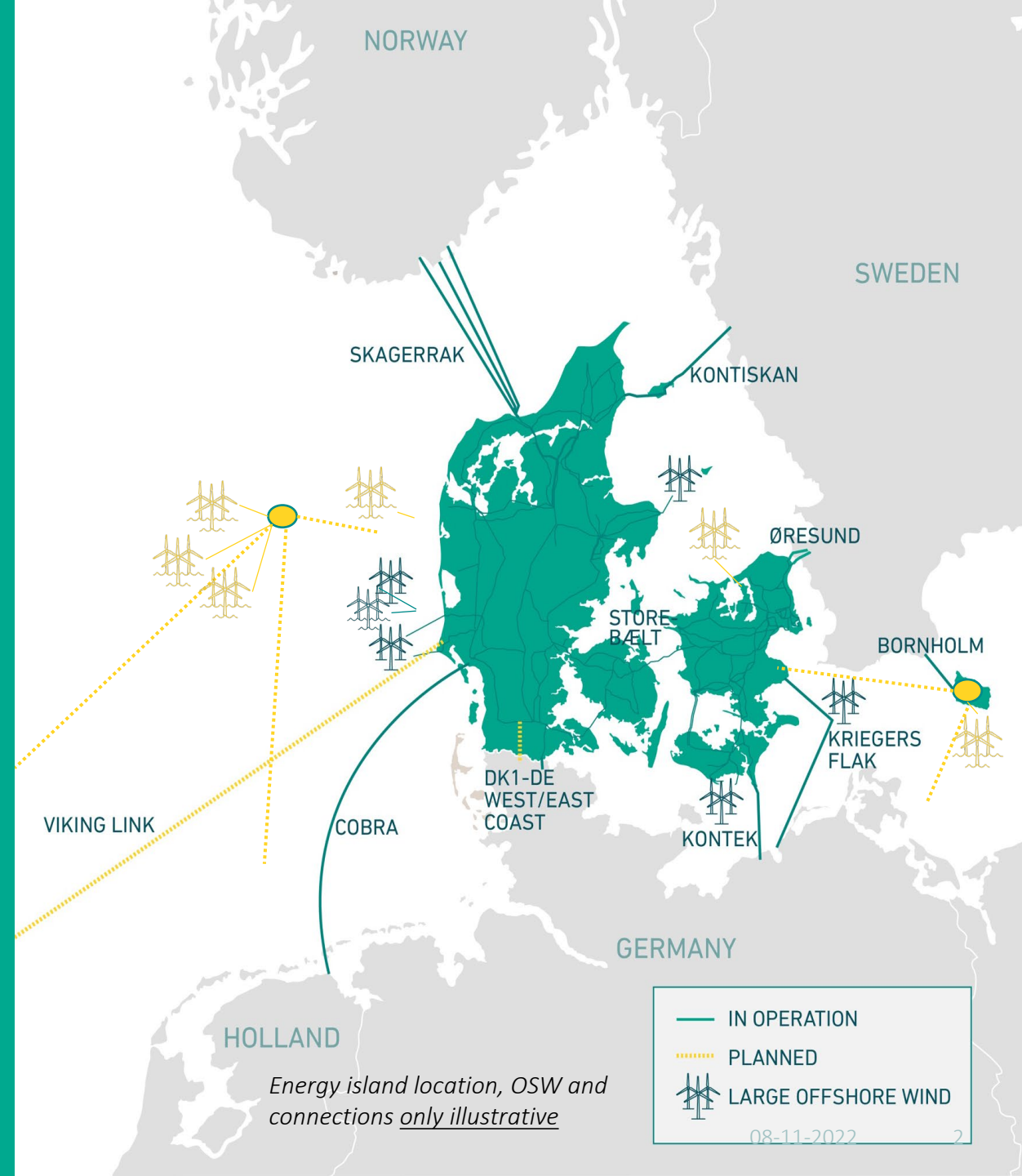

# FUTURE OSW BUILD OUT

Accelerate development and continue to reduce costs, risks and uncertainty

## ACCELERATE DEVELOPMENT:

- Larger OSW tender size (from 200 MW to 3 GW)
- Speed up decision process (and proactive grid planning)
- Parallel build out of tenders and open door projects

## REDUCE COSTS AND RISKS

- Hybrid onshore grid connection
- Development of meshed offshore grid (backbone)
- Direct line from OSW to onshore Power to hydrogen

## REDUCE UNCERTAINTY

- Market dialogue!
- New tariff and connection payment structure
- Take supply chain issues into account
- Cooperation on HVDC technology development

## ACCELERATED DEVELOPMENT TO REDUCE USE OF FOSSIL FUELS AND FASTER GREEN TRANSITION

*From 2021 to 2022 large change in DEA planning assumptions for solar and offshore wind capacity (GW)*

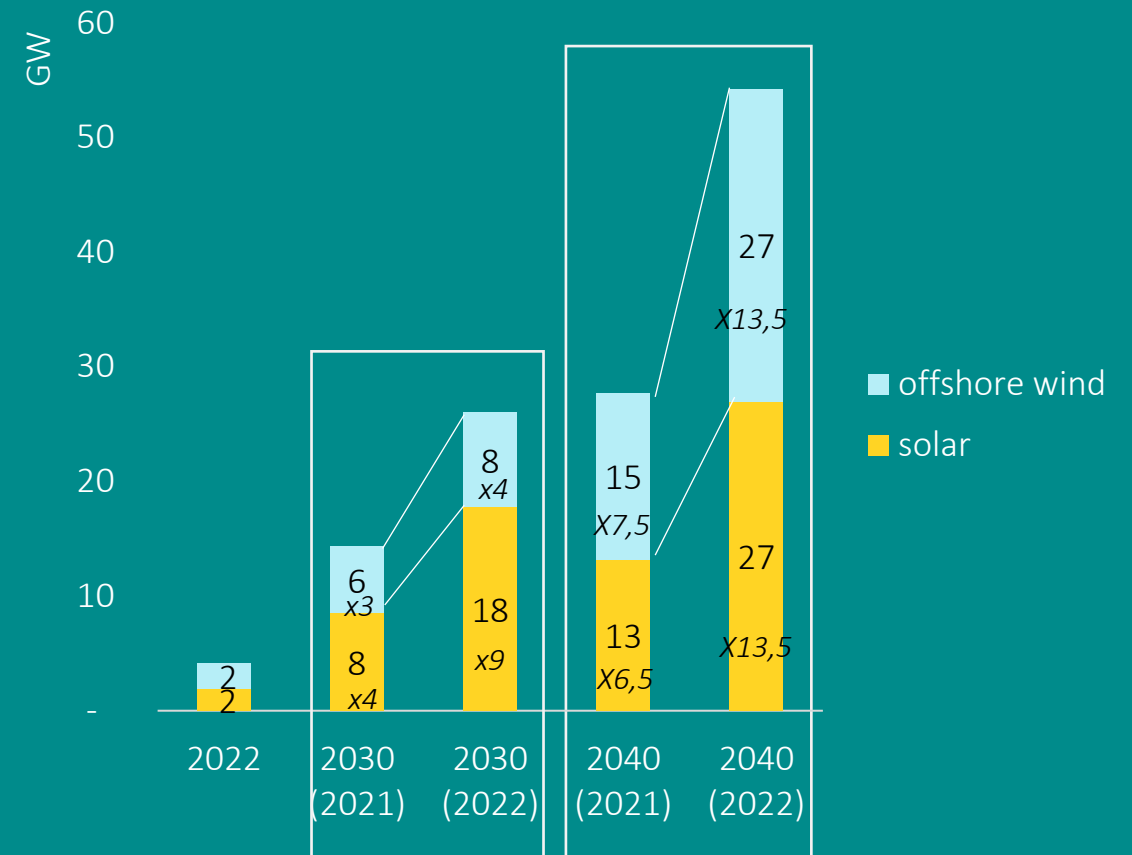

*Source: Danish Energy Agency, 2021 and 2022 public hearing version*

# Energy island Bornholm

## Climate Agreement

Add. August 2022

Visualisation of HVDC and onshore connection

3 GW offshore wind  
Operation 2030

**ENERGINET**

[Energy Island Bornholm | Energistyrelsen \(ens.dk\)](#)

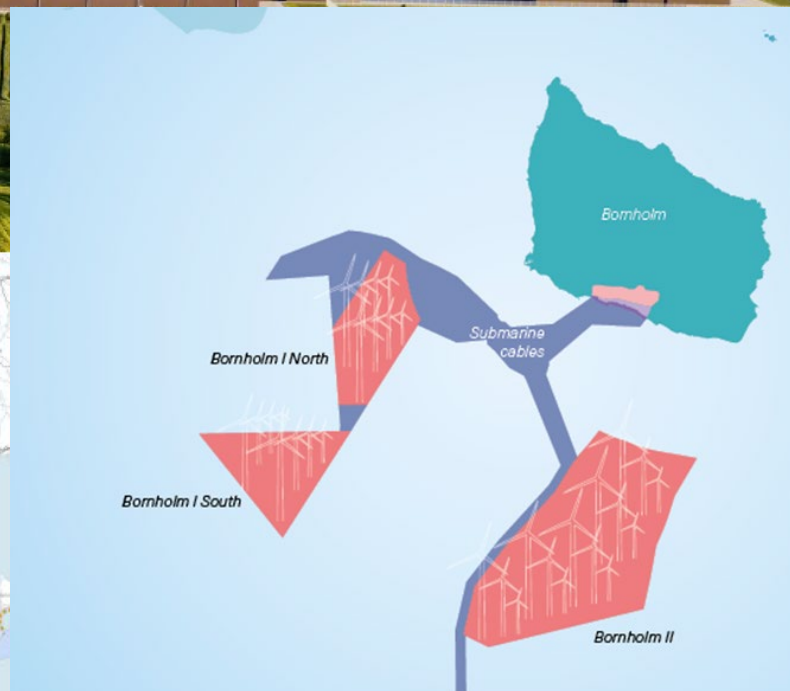
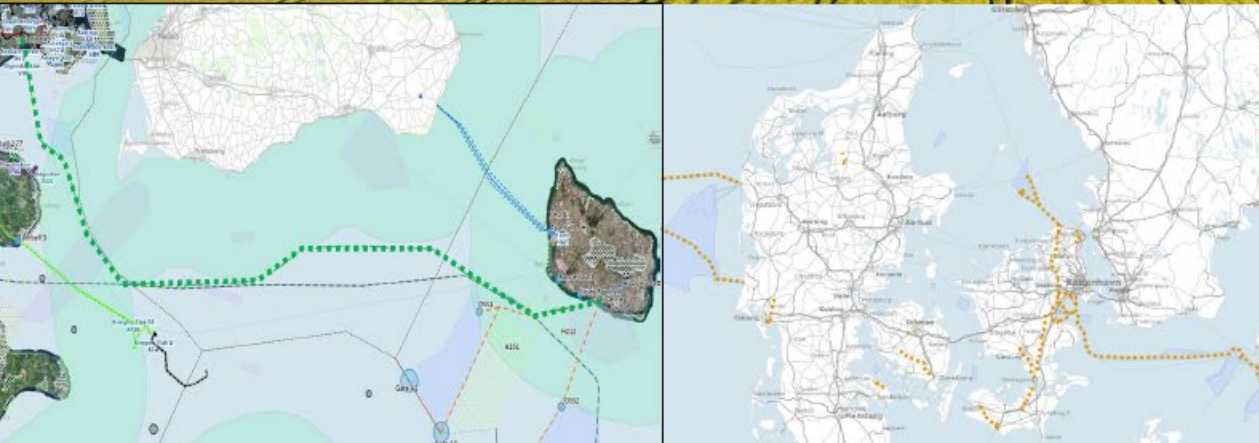

# SOCIO ECONOMIC BUSINESS CASE- BORNHOLM

Business case for electricity infrastructure politically approved October 2022

Based on cost benefit analysis for most optimal connection of 3 GW:

- Estimated 67 bill DKK investment (infrastructure and wind turbines)
- Socio economic business case not positive and need for subsidies or other kind of support
- Electricity infrastructure be tarif neutral for consumers
- Large uncertainty on electricity prices and dependency on especially HVDC technology development !

[business case not public available due to confidentiality before tenders]

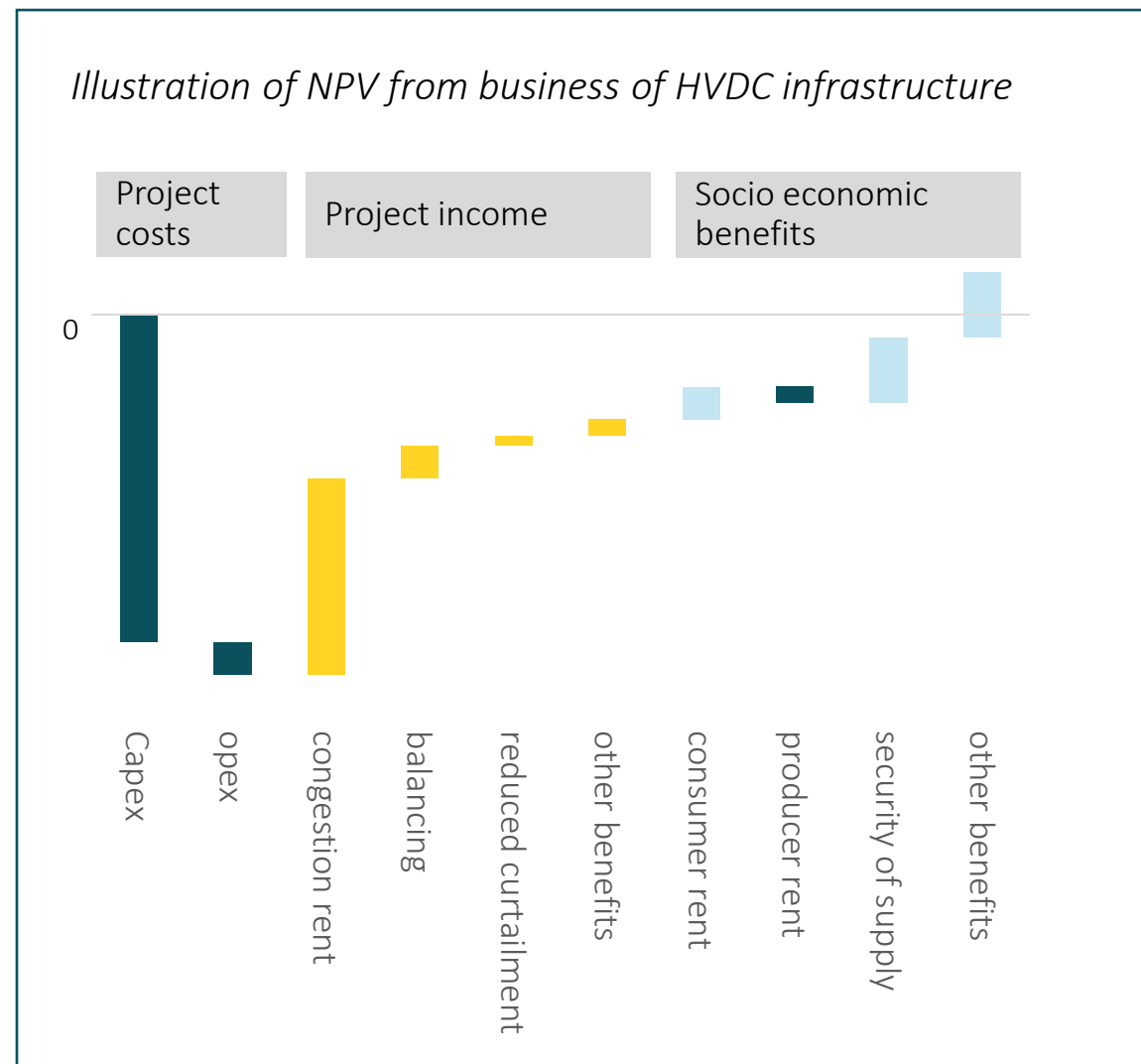

# POI FOR BORNHOLM ENERGY HUB

Change in responsibility and allocation of costs  
- again

	Horns Rev 3	Thor/ Hesselø	Bornholm Energy hub
Offshore substation/ cables	Energinet (build/operate) Developer (pay)	Developer	Developer
Onshore connection	Energinet (build/operate) Developer (pay)	Developer	Developer
Internal grid extension	Energinet	Energinet	Energinet
HVDC grid	-	-	Energinet (build and operate) Developer (pay for use)

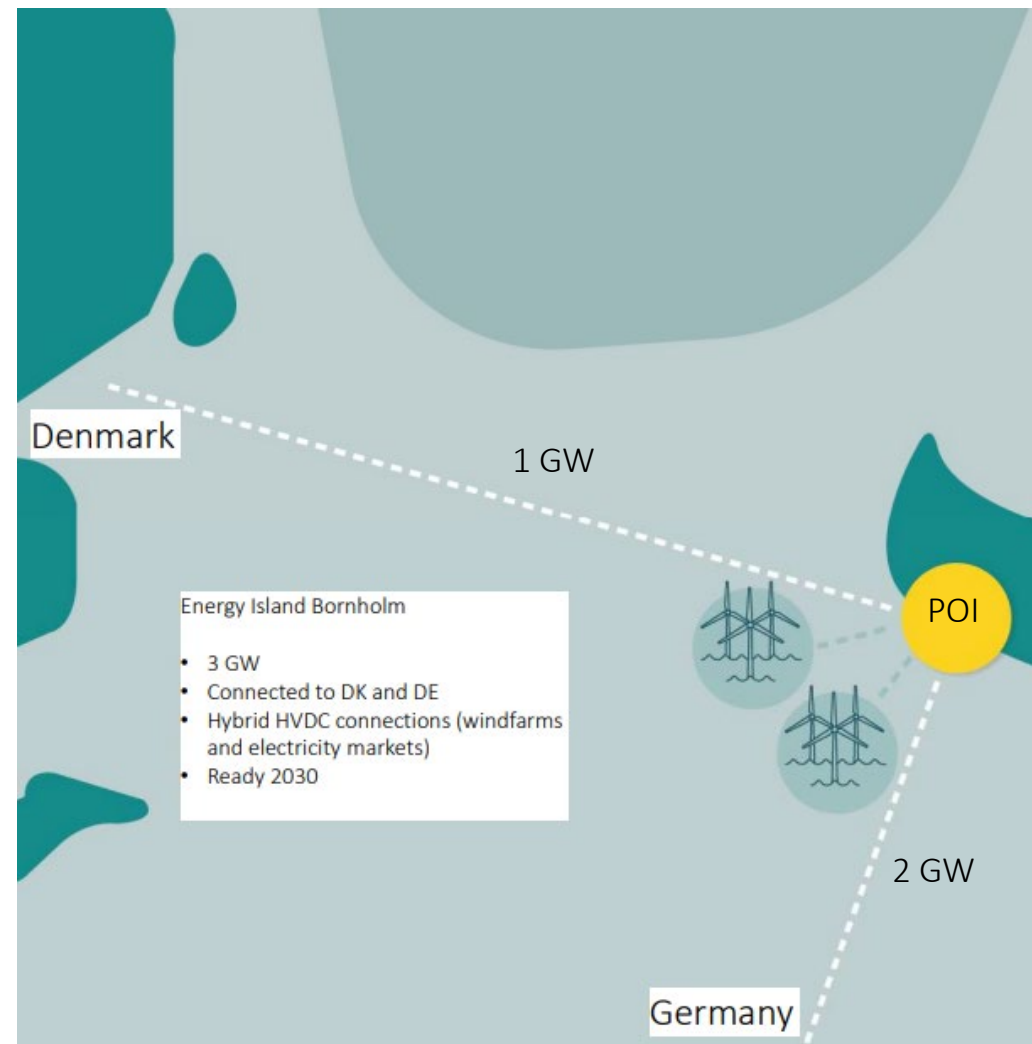

# DANISH NORTH SEA Energy hub - 3 GW and up to 10 GW

Part of North-Sea Wind Power Hub and +300 GW OSW potential

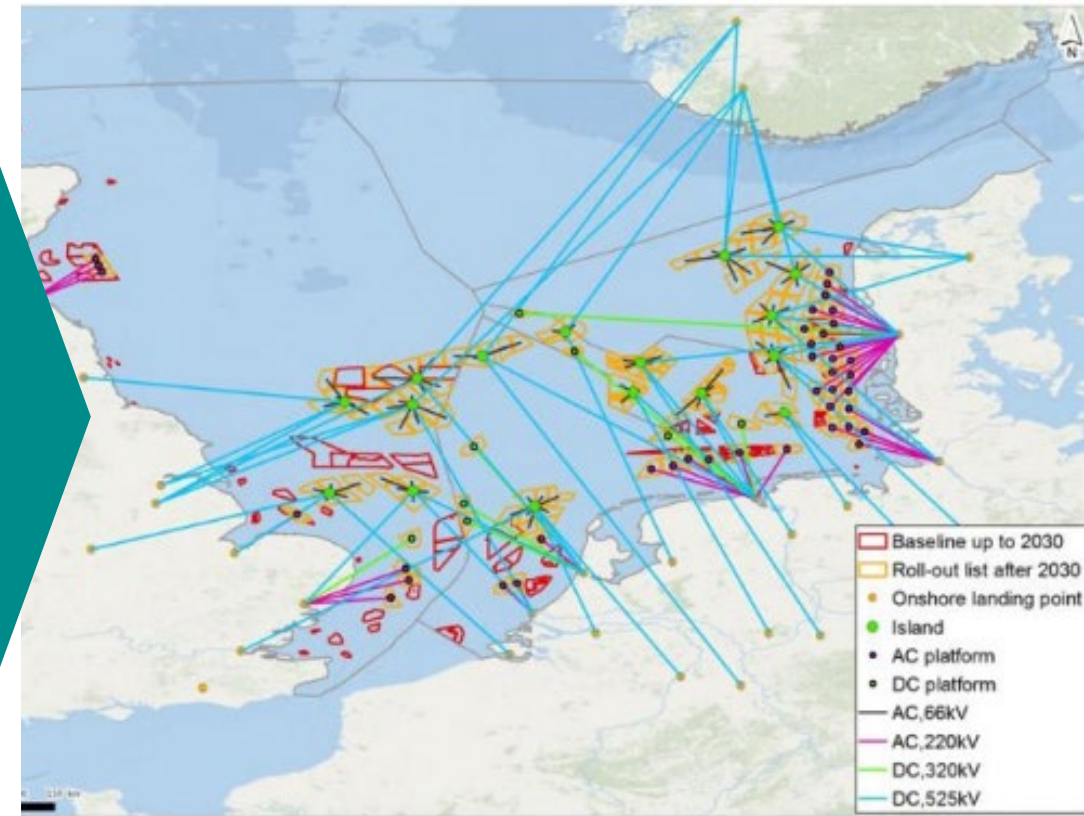
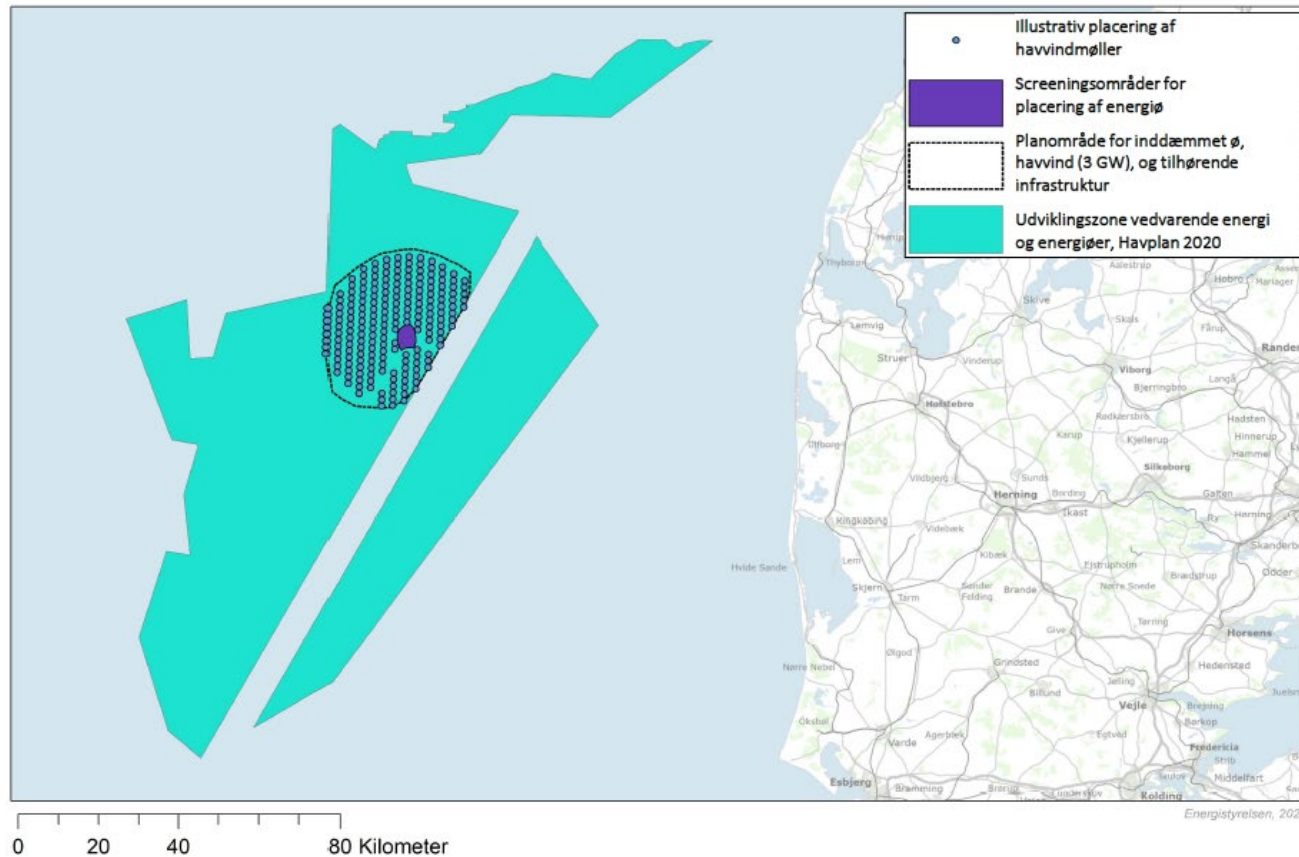

North Sea Wind Power Hub



# PHASES FOR ENERGY ISLAND

## Phase 1: (3GW OWF) + (3.4GW transmission) 2033

- HVDC transmission to DK1 and BE
- HVAC (4GW) & HVDC switch gear on island
- Separate HVDC-platforms
- HVDC/HVAC onshore station DK1 (Revsing + land cable)

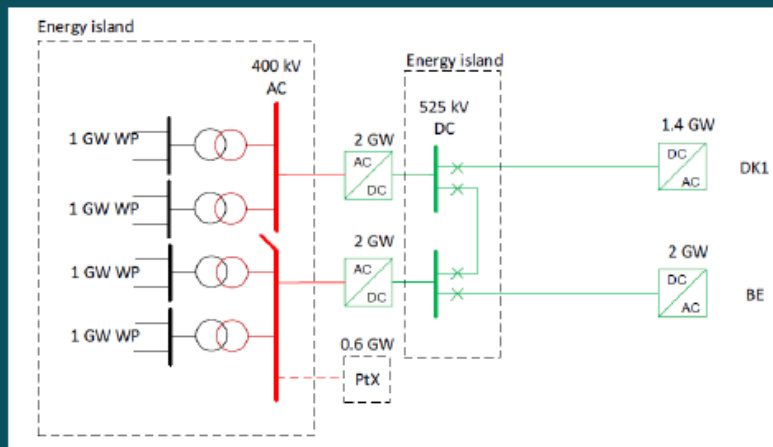

## Phase 2: (+3GW OWF) + (x GW IC) 2035-37

- 1GW OWF connected to island
- 2GW OWF connected to separate HVAC/HVDC platform
- HVDC switch gear on island

## Phase 3: (+4GW OWF) + (x GW IC) 2040

- 2 x 2GW platforms
- HVDC switch gear on island

## Illustration

Long term ttimeplan and concept not decided

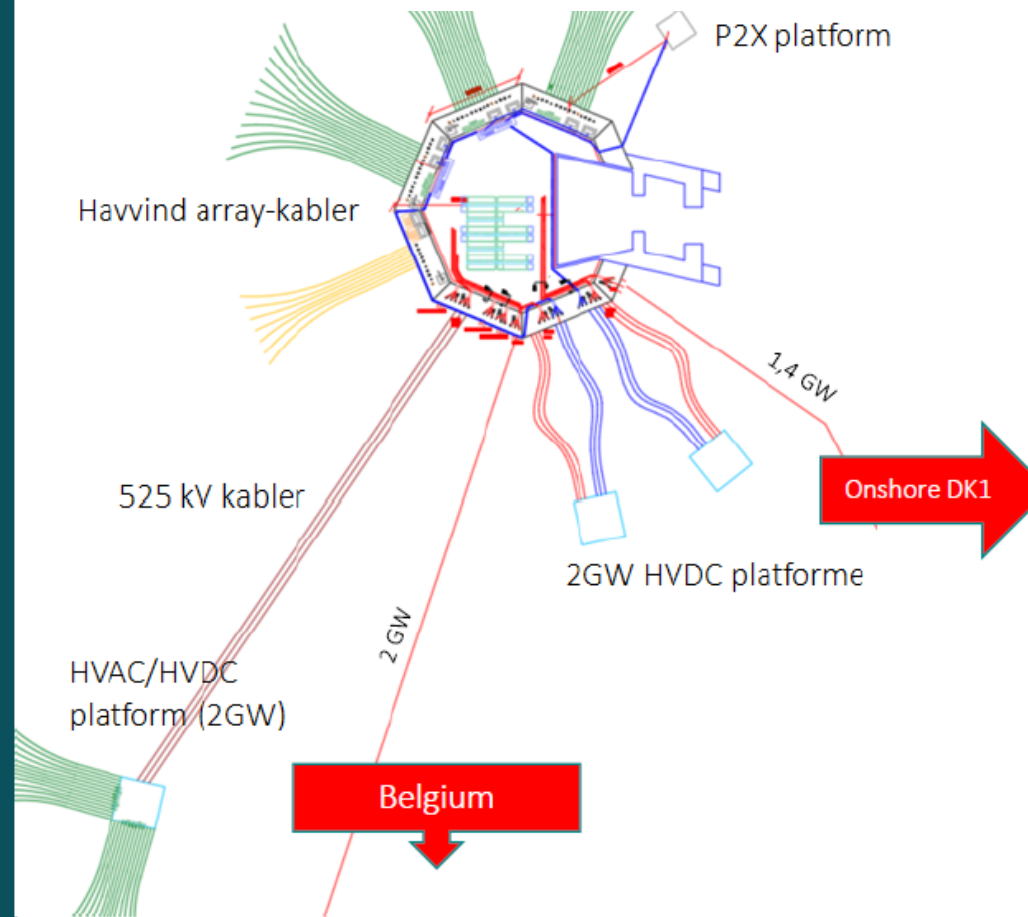

Expected commissioning 2033  
 Tie lines operational from 2031  
 Expected positive socio economic business case

## OSW AS PART OF ENERGINET LONG TERM GRID PLANNING



Large build out of OSW, onshore wind and solar



Maintain high Security of supply



Ageing grid and need for re-investments

- Grid development financed by tariff
- Reform of tariff - from consumer to user to pay (ie. capacity payment, increased connection fee, locational tariffs, direct lines)

# POWER TO HYDROGEN AS FUTURE CONNECTION SOLUTION

Flexibility and efficient utilization of electricity with combination of hydrogen and electricity production

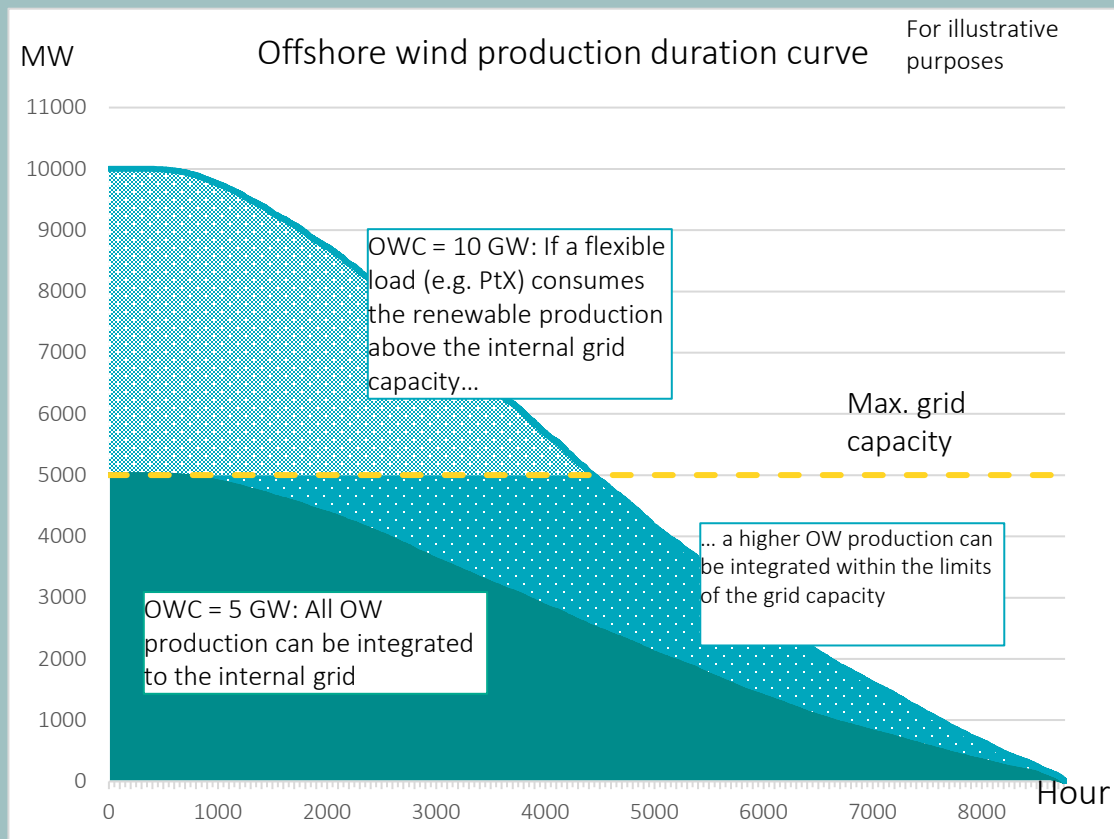

# DEVELOPMENT OF HYDROGEN PRODUCTION IN DENMARK

- 6-7 GW expected for 2030
- Hydrogen infrastructure needed

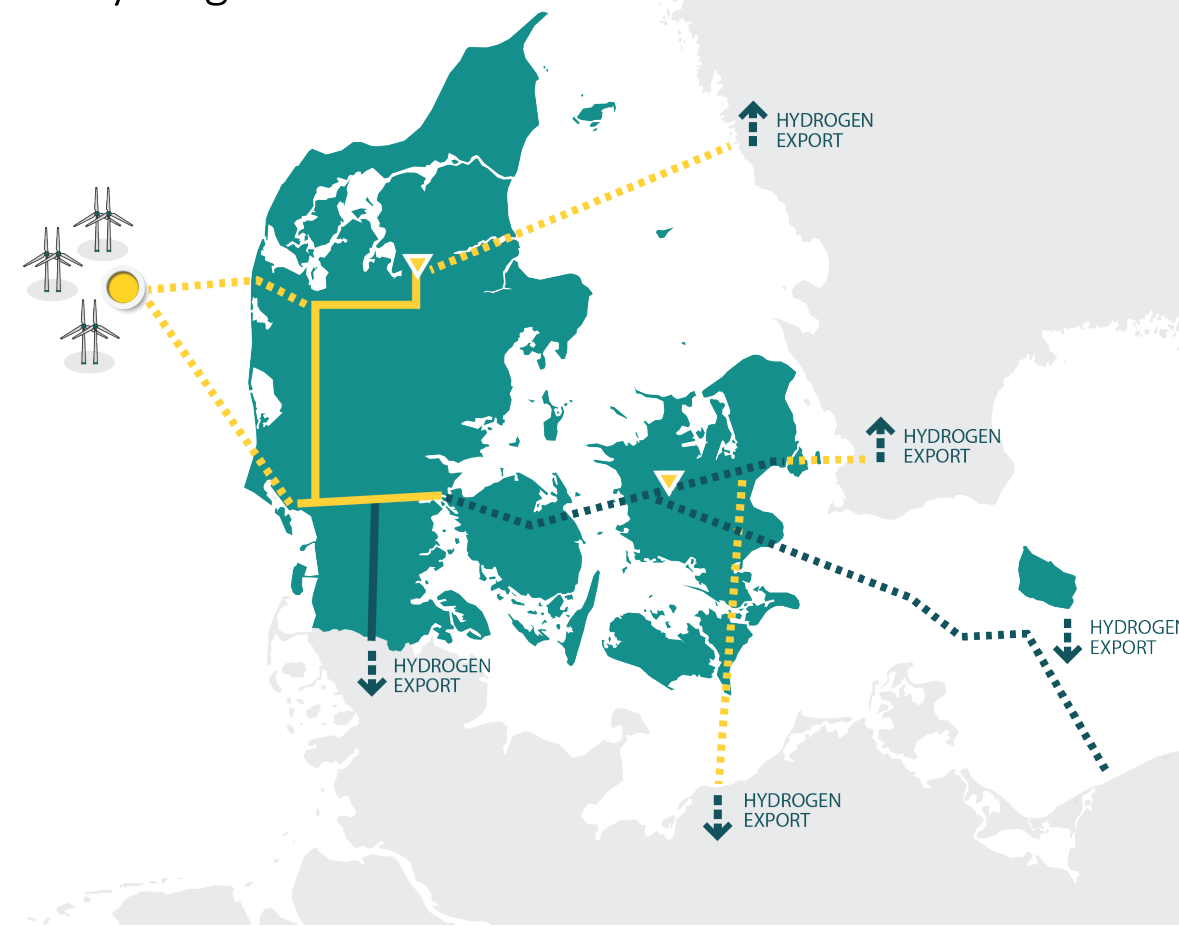

A photograph of two white wind turbines on a grassy dune overlooking the ocean under a blue sky with scattered clouds. The turbines are positioned on a green dune with tall grasses in the foreground. The ocean is visible in the background, and the sky is a deep blue with some light clouds. The text "Thanks for your attention" is overlaid in white on the right side of the image.

Thanks for your attention

# BACK UP

## WHAT HAS BEEN ACHIEVED IN THE LAST 20 YEARS ACCELERATES TOWARD 2040

Electricity generation and peak capacity, GW

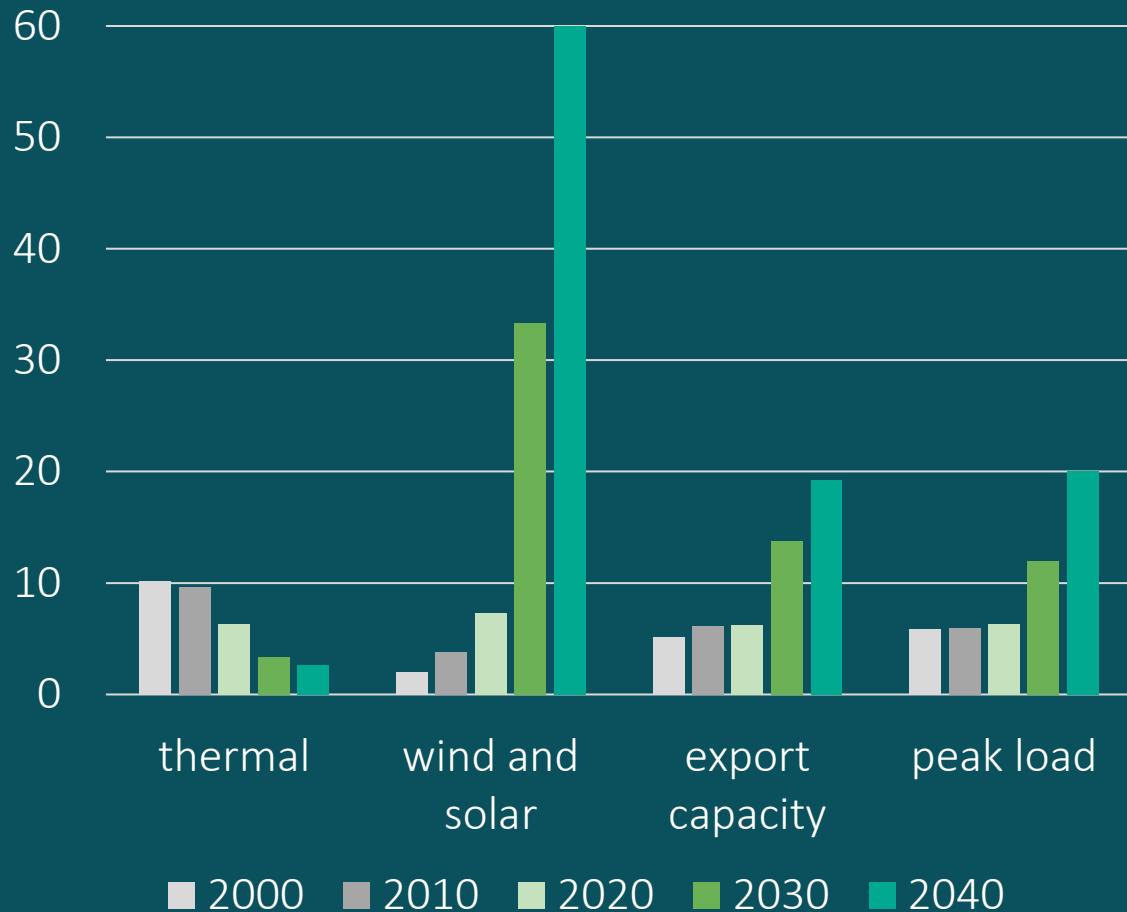

## ELECTRIFICATION DRIVES THE CHANGE TO A CLIMATE NEUTRAL ENERGY SYSTEM

Electricity consumption, TWh

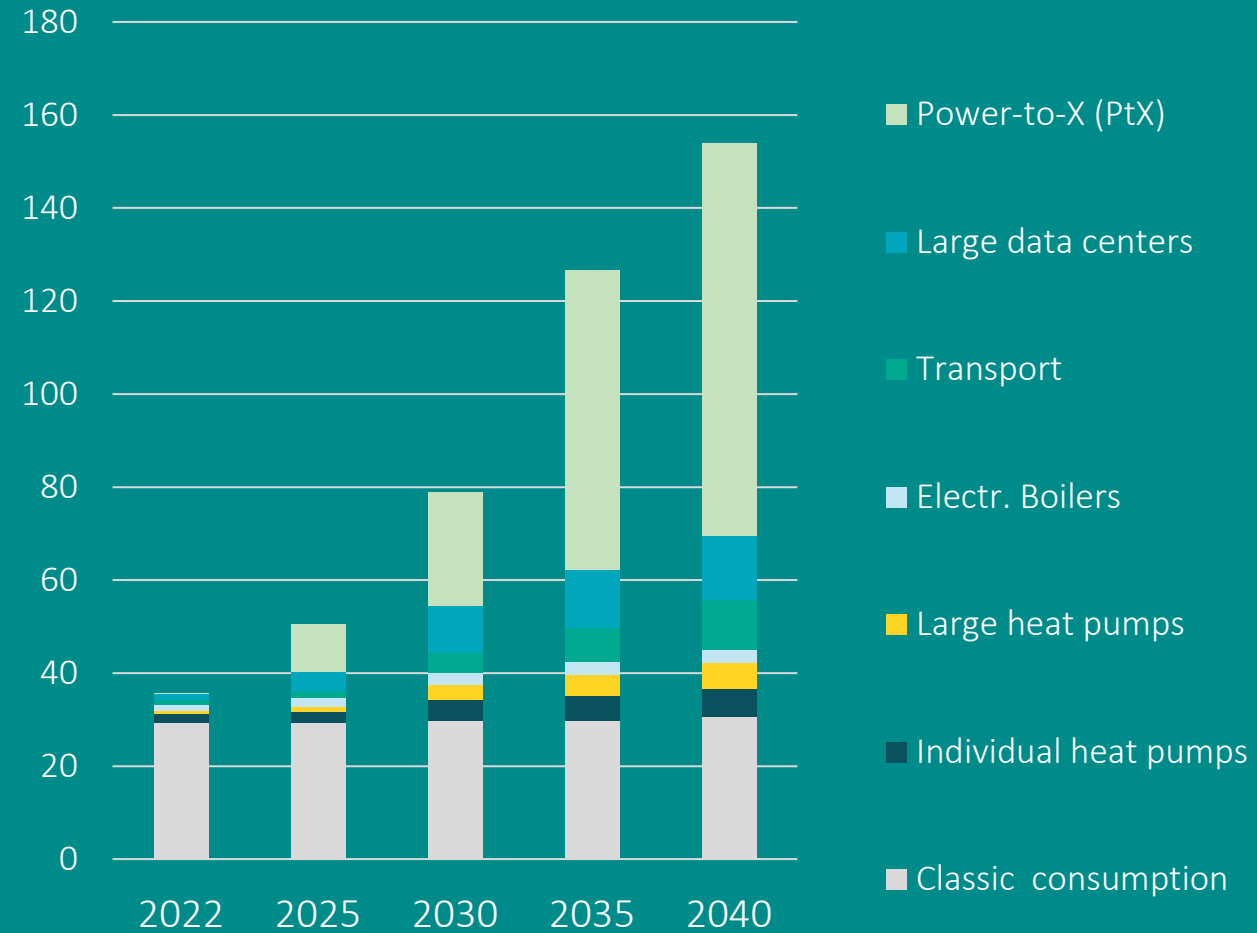

Source: Danish Energy Agency, draft assumptions 2022

# ACCELERATE DEVELOPMENT

## LARGER OSW PROJECTS

- Larger lease areas
- From fixed MW tender to capacity range based on lease area
- Both open door and tender solutions

## DECISION PROCES

- Speed up environmental impact assessment process
- Early dialogue with stakeholders

## INTERNAL GRID DEVELOPMENT

- Early dialogue DEA and Energinet on potential areas for OSW
- Grid planning include anticipated connection of VRE

# REDUCE COSTS

## HYBRID CONNECTION

- Freedom for developer to optimize connection with solar, battery, electrolyzer above connection capacity

## DIRECT LINES

- Develop necessary regulation for direct lines (from OSW to hydrogen)
- Energinet only owner of transmission grid in Denmark today

## DEVELOPMENT OFFSHORE GRID

- Political agreements on OSW development (By 2030 65 GW North Sea and 20GW in Baltic Sea)
- Energinet dialogue with other TSO on new tie lines



# REDUCE UNCERTAINTY

## SUPPLY CHAIN ISSUES

- Close market dialogue on development of supply chain issues
- Ensure balanced tender agreements between TSO and developer

## CONNECTION COSTS

- Connection costs fixed in tender – budget risk on Energinet
- HVDC link is Energinet responsibility and tariff payment for use
- Open for future direct line and hydrogen connection

## TECHNOLOGY DEVELOPMENT

- Developer freedom to choose technology
- Technical requirements at onshore connection
- TSO, developers and manufactures common R&D/standardization projects

# ECONOMICS – THREE EXAMPLES

Budget for offshore and onshore connection very dependent on specific site and need for internal transmission grid upgrades

	Anholt, 2013	Horns Rev 3, 2019	Kriegers Flak (2021)	Thor (2024)	Bornholm Energy hub	North sea energy hub
Capacity	400 MW	407 MW	605 MW	1000 MW	2 GW	3-10 GW
Budget for connection*	170 mio. Euro	230 mio. Euro	386 mio. Euro**	92 mio. Euro***	2.4 bill Euro****	3.8-14.0 bill. Euro****
Planning time from approval (political agreement)	2010-2013 (2008)	2013-2016 (2012)	2014-2020/2021 (2012)	2018-2023 (2018)	2022-2030 (2021)	2022-2035 (2021)
Off/onshore cable	30/56 km	35/58 km	85/105 km	-	Ca. 1000 km	Ca. 1700 – 7200 km
Offshore Transformer	Yes	Yes	Yes	-	yes	yes
Onshore cable station	Yes	Yes	Yes	Yes	Yes	Yes
Extension onshore	Yes (220 kv)	Yes (220 kv/400 kv)	Yes (220/400kv)	Yes	Yes	Yes
Extension internal grid	No	Yes (29 km 400 kv)	Yes (400 kv+ btb HVDC)	Yes	Yes (HVDC)	Yes (HVDC)

\*public available budgets from Energinet application for project

\*\*Energinet part of investment and incl. 150 mio. Euro EU subsidy

\*\*\* only budget for onshore connection. Offshore cable and connection responsibility of developer

\*\*\*\*based on report from consultant – business case and ownership model still being devoped, [a209704-001\\_cost\\_benefit\\_analyse\\_endelig\\_version.pdf \(ens.dk\)](#)

# HOLISTIC ENERGY PLANNING – DENMARK CASE SCENARIO YEAR 2035 **ENERGINET**

