

**DOCKETED**

<b>Docket Number:</b>	21-AFC-02
<b>Project Title:</b>	Willow Rock Energy Storage Center
<b>TN #:</b>	246219
<b>Document Title:</b>	Attachment DR109-1 Data Response Set 1B
<b>Description:</b>	Transmittal email to Lon Payne and Attachment DR109-1
<b>Filer:</b>	David Stein
<b>Organization:</b>	WSP Golder
<b>Submitter Role:</b>	Applicant Consultant
<b>Submission Date:</b>	9/27/2022 3:41:43 PM
<b>Docketed Date:</b>	9/27/2022

**From:** [Stein, David](#)  
**To:** [Payne, Leonidas@Energy](mailto:Payne, Leonidas@Energy)  
**Cc:** [Nyree Grimes](#); [Curt Hildebrand](#); [Jeff Harris](#); [Samantha Neumyer](#); [Masson, Peter](#); [Paris, Jeremy](#); [Miller, Kari](#)  
**Subject:** Attachment DR109-1 for Willow Rock Data Response Set 1B (21-AFC-02)  
**Date:** Tuesday, September 27, 2022 3:04:00 PM  
**Attachments:** [image002.png](#)  
[Attachment DR109-1 Willow Rock Energy Storage Center Interconnection to LADWP Rosamond Substation.pdf](#)

---

Hi Lon –

Data Response 109 inadvertently identified Attachment DR109-1, the Willow Rock Energy Storage Center (WRESC) one-line diagram for the interconnection to LADWP’s Rosamond substation, as a confidential document. Since it is not confidential, I am attaching it here. Please note – although the diagram refers to the project by the name Rosamond Energy Center, this is in fact the applicable single line diagram for the WRESC interconnection that was included with the LADWP interconnection application.

This email and attachment will be filed in the docket for the proceeding.

Please let me know if you have any questions.

Thanks  
Dave



**David A. Stein, PE**  
Director, Environmental Planning & Permitting

T+ 1 925-956-4800  
M+1 510-520-6787

WSP USA  
1575 Treat Boulevard, Suite 201  
Walnut Creek, CA 94598

[wsp.com](http://wsp.com)

PROTECTIVE FUNCTIONS

- (25) SYNCH-CHECK
- (27) UNDER-VOLTAGE
- (50) INSTANTANEOUS PHASE
- (50N) INSTANTANEOUS GROUND
- (51) OVER-CURRENT PHASE
- (51N) OVER-CURRENT GROUND
- (59) OVERVOLTAGE
- (59N) OVERVOLTAGE GROUND
- (81) FREQUENCY (OVER AND UNDER)
- (87T) TRANSFORMER DIFFERENTIAL RELAY

LEGEND

- (M1) UTILITY METER (TELEMETER)
- (M2) CAISO METER (TELEMETER)
- (M3) CAISO BACKUP METER (TELEMETER)
- (A) 230KV PTS - ABB 230KV CONNECTED LINE-GROUND, 0.3% ACCURACY, 1.8 BURDEN
- (B) 230KV BREAKER, 3000A WITH 40KA AIC
- (C) BUNDLED OF 2X1590 ACSR (LAPWING), SUMMER NORMAL RATING IS 1877 AMPS
- (M) 230KV MOTOR OPERATED SWITCH, 2000A RATING
- (52) CIRCUIT BREAKER

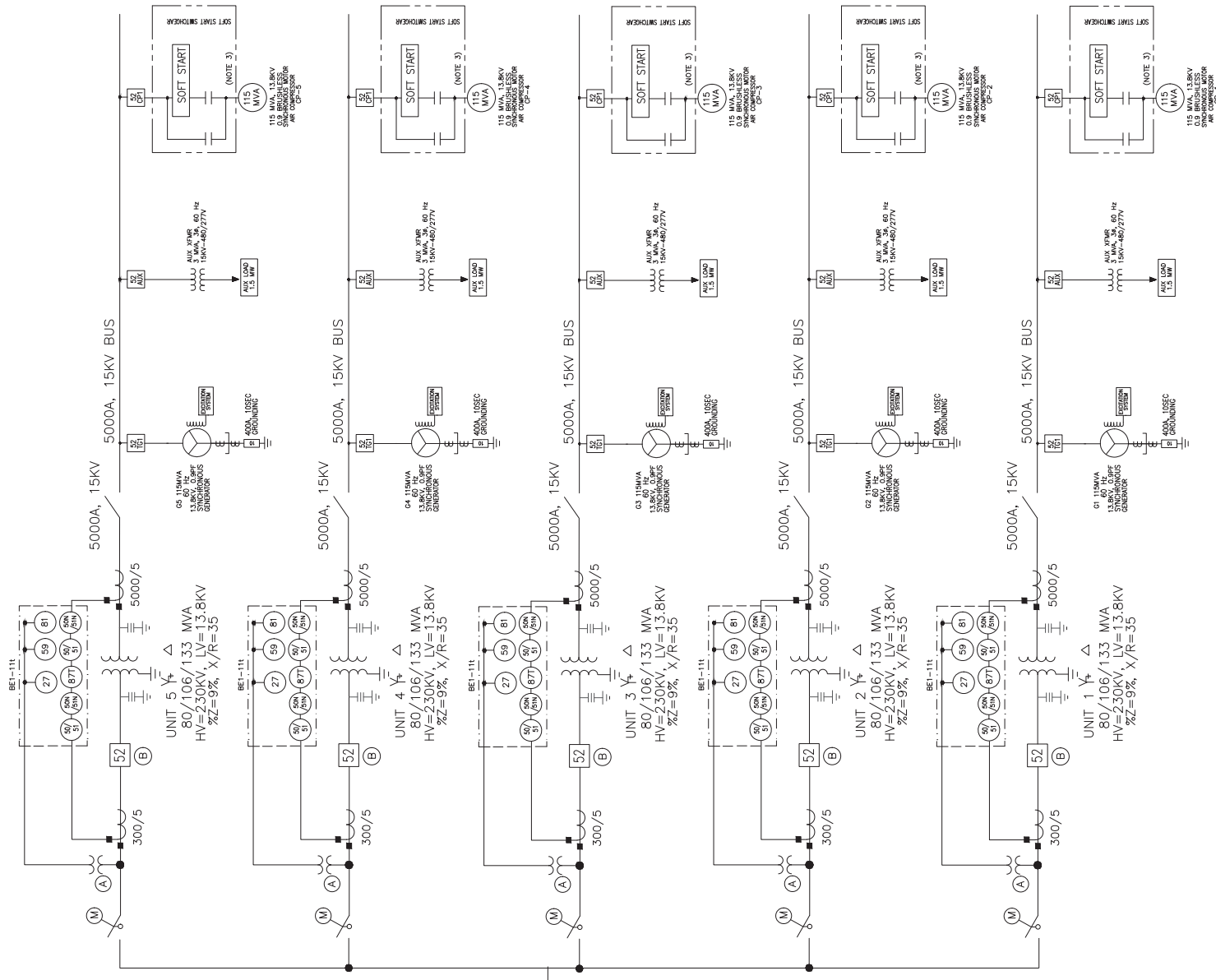
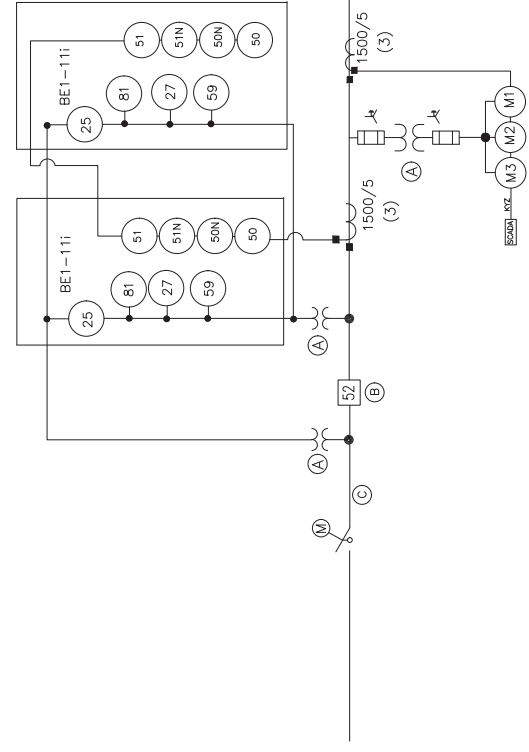

SYNCHRONOUS GENERATOR INFORMATION	
SYNCHRONOUS GENERATOR	115MVA, 0.9PF
# OF GENERATORS	5
TOTAL GENERATOR POWER	575 MVA

3 SOFT START INVERTER AND ASSOCIATED SWITCHGEAR SHALL BE DESIGNED TO START THE AIR COMPRESSOR AT A RATE IN ACCORDANCE WITH THE OPERATING PARAMETERS OF THE POWER GENERATION PLAN.

PROJECT NAME: ROSAMOND ENERGY STORAGE  
SUBSTATION SINGLE LINE

ORIG. SIZE 24"x36"  
0 1/2" 1"

E101  
JOB NUMBER

NO.	DATE	REVISIONS
0	10/02/20	INITIAL DESIGN

ENGINEER'S STAMP  
DESIGNED BY: CMC  
CHECKED BY: DS  
ENGINEER & NO.: CMC



PROJECT OWNER: HYDRO STOR

