

DOCKETED

Docket Number:	01-AFC-19C
Project Title:	SMUD Cosumnes Power Plant - Compliance
TN #:	244289-18
Document Title:	Supplement C - Figure 8_143dR
Description:	N/A
Filer:	Patty Paul
Organization:	Ch2mhill/Carrier
Submitter Role:	Applicant Consultant
Submission Date:	8/1/2022 5:57:17 PM
Docketed Date:	8/1/2022

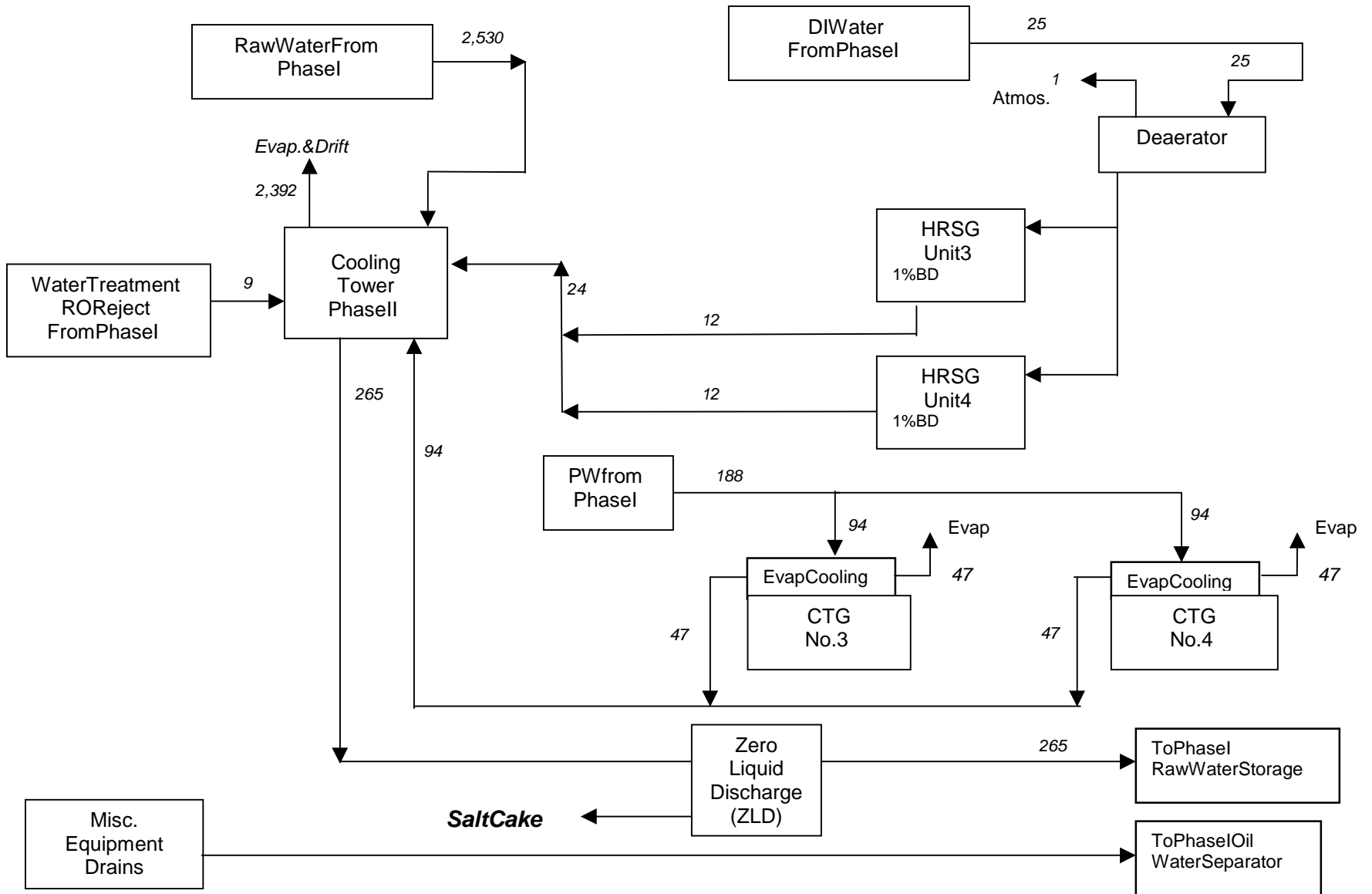

NOTES:
 ALL FLOW RATES ARE GIVEN IN GPM.
 FLOWS ARE BASED ON FULL LOAD OPERATION WITH AN AMBIENT TEMPERATURE OF 104 DEGREES F, 70 WB.
 COOLING TOWER BLOWDOWN IS BASED ON MAINTAINING 10 CYCLES OF CONCENTRATION.
 FLOWS ARE BASED ON FOLSOM SOUTH CANAL WATER CONSTITUENTS SPECIFIED.

Figure 8.14.3dR
Cosumnes Power Project
Phasel I – 104F Peak
 WATER BALANCE DIAGRAM
 PBPOWER, INC.