

DOCKETED

Docket Number:	20-LITHIUM-01
Project Title:	Lithium Valley Commission
TN #:	241577
Document Title:	Nikola Lakic Comment on following the virtual Lithium Valley Commission Meeting conducted on Thurs, Jan 27, 2022 (6 of 6)
Description:	N/A
Filer:	System
Organization:	Geothermal Worldwide, Inc./Nikola Lakic
Submitter Role:	Public
Submission Date:	2/17/2022 10:48:12 AM
Docketed Date:	2/17/2022

*Comment Received From: Nikola Lakic
Submitted On: 2/17/2022
Docket Number: 20-LITHIUM-01*

**Nikola Lakic - Comment following the virtual Lithium Valley
Commission Meeting conducted on Thurs, Jan 27, 2022 (6 of 6)**

Additional submitted attachment is included below.

System for Drilling Deeper and Wider Wellbores

Nikola N. Lakic

78-365 Hwy 111, #402, La Quinta, California, 92253

nlakic@GeothermalWorldwide.com

Keywords: drilling wellbores, motorized drill-head, geothermal energy, closed-loop system, heat exchange, electricity, clean environment

ABSTRACT

Contemporary drilling systems for wellbores have serious limitations on how wide and deep wellbore can be drilled. In conventional systems, mud is injected through the pipe and exit through several orifices at drill-bit and circulates up between the pipe and wall of the wellbore providing a necessary stream for cutting to be excavated. By increasing the size of the drill-bit (wellbore) and/or by increasing the depth of the wellbore it requires a tremendous increase of pressure inside the pipe to form a sufficient stream of fluid up for cuttings to be excavated. Also, the wellbore has a gradually smaller diameter with each subsequent section because of the casing.

The presented system provides a solution for drilling deeper and wider wellbores with a constant diameter. The presented system consists of a motorized drill head; separate excavation line; separate fluid delivery line, and a separate closed-loop cooling line engaged with Binary Power Unit on the ground surface. The presented drilling apparatus has retractable bits on the motorized drill head. The casing of the wellbore can be built during the drilling process. The drilling apparatus consists of the elevator sliding over the drilling/excavation/heat exchange apparatus delivering and installing casing sheets and concrete. The elevator also has an expendable chamber, and containers for delivering air, and concrete. The containers with air also can be used for providing buoyancy thus minimizing the weight issue during the disassembling process. The diameter of the excavation line and rate of flow of mud and cuttings through it and the diameter of the fluid delivery line and rate of fluid flow through it are in balance requiring only a limited fluid column at the bottom of the wellbore. The fluid column may exist through the whole wellbore to sustain the wellbore during the drilling process, and later for better conduction of the heat, but not for the excavation purpose. The excavation process continues regardless of the diameter of the drill head (wellbore); therefore, this method eliminates well-known drilling limitations relative to the depth and diameter of the wellbore.

1. INTRODUCTION

1.1 Note

Presented paper with the title “System for Drilling Deeper and Wider Wellbores” is a segment of the comprehensive design for the long-term solution for the restoration of the Salton Sea (Lake in California). The solution for the restoration of the Salton Sea includes an architectural element that harmoniously implements several breakthrough technologies into a self-sustaining organism. There are five phases (segments) of the project including harnessing solar and hydro energy which are excluded for this occasion as not relevant to the geothermal issue. Each of the phases (segments) is essential for the final result of the project. The presented “System for Drilling Deeper and Wider Wellbores” is a fundamental segment of the comprehensive design on which the function of other segments depends.

For this occasion, the paper “System for Drilling Deeper and Wider Wellbores” is marked as a (Segment III). For a complete understanding of this segment it is necessary to review the other two integral parts of the comprehensive design with titles “Harnessing Energy and Water in the Salton

Sea” as a (Segment I), and “Harnessing Geothermal Energy with the Self Contained In-Ground Geothermal Generator and Self Contained In-Ground Geothermal Heat Exchanger” as a (Segment II).

1.2 Overview of the contemporary drilling system

Contemporary drilling systems for wellbores have serious limitations on how wide and deep wellbore can be drilled. Mud is injected through the pipe and exit through several orifices at drill-bit and circulates up between the pipe and wall of the wellbore providing a necessary stream for cutting to be excavated. By increasing the size of the drill bit (diameter of the wellbore) and/or by increasing the depth of the wellbore it requires a tremendous increase of pressure inside the pipe to form a corresponding stream up for cuttings to be excavated. Also, wellbores have a gradually smaller diameter with each subsequent section because of the casing.

Relevant to the presented proposal for the restoration of the Salton Sea which includes many power plants using a completely closed-loop system for harnessing geothermal energy and each of those power plants having 24 wellbores there is a need for a system for drilling faster, deeper and wider wellbores.

1.3 Summary of the new system for drilling faster, deeper, and wider wellbores

Presented system for drilling faster, deeper and wider wellbore consist of motorized drill head; separate excavation line; separate fluid delivery line; and separate closed-loop cooling line engaged with the Binary Power Unit on the ground surface which generates electric energy. The presented drilling apparatus has retractable bits on the motorized drill head (See FIG. 8). The apparatus also consists of the elevator sliding over the drilling/excavation/heat exchange apparatus (line) delivering and installing casing sheets and concrete during the drilling process (See FIG. 2-3).

The motorized drill head cuts and shred ground material and suck into the excavation line for transporting it to the ground surface. The whole excavation line consists of multiple segments of the electric motor, the “In-Line Pump, with a continuous spiral blade inside the rotor.

The separate fluid delivery line delivers filtered fluid into the bottom of the wellbore for easier cutting and partially cooling the drill head (See Fig. 1 and 8). Separate closed-loop cooling line function as a closed-loop heat exchange system taking heat from the motorized drill head and transporting it into a binary power unit on the surface which can produce electricity which can be used to supplements energy needed for powering the motorized drill head. The drill head can be powered by an electric motor or hydraulic motor.

The circular cage slides up and down over the excavation line delivering and installing casings (See Figs. 2, 3, and 7). The circular cage has an expandable compartment with a bladder on which is attached rolled adjustable metal sheets although does not need to be metal. The bladder is made of heat resistant material and expands when air from the air containers is injected into the bladder and the metal sheet is inserted in needed location. Concrete from the concrete containers is injected between the metal sheet and rough wall of the wellbore forming the casing. The bladder can stay inflated as needed until the curing of concrete is completed. This process can be repeated as needed. The drilling process can continue except for a short interruption during positioning metal sheets for the casing. The circular cage has a motor compartment with gears that are synchronized with a cable system for sliding the cage up and down. The cage also has a locking system. Several cages, with air containers when locked to the excavation line, can provide buoyancy for the whole apparatus controlling the drilling force and eliminating difficulties caused by the weight of the apparatus during the disassembling process.

The diameter of the excavation line and rate of flow of mud and cuttings through it and the diameter of the fluid delivery line and rate of fluid flow through it are in balance requiring only a

limited fluid column at the bottom of the wellbore. The fluid column may exist through the whole wellbore to sustain the wellbore during the drilling process and for better conduction of heat but is not necessary for the excavation purpose. The excavation process continues regardless of the diameter of the drill head (wellbore); therefore, this method eliminates well-known drilling limitations relative to the depth and diameter of the wellbore (See FIG. 1-8).

With presented technology now we can tap to limitless geothermal energy with less limitations.

ADDENDUM

(The section “2” below is added later after submission of paper)

2. Preliminary Cost Estimate and Revenue for the Proposed Power Plant:

The Proposed Geothermal Power Plant(s) - the “Scientific Geothermal Technology” consists of 24 well-bores and with many projected power plants (in 100s) drilling is most expensive and most important part, therefore we need to implement a new system for drilling faster, deeper, and wider wellbores.

2.1 Preliminary Cost Estimate for the Proposed Power Plant:

(See Segment 3+ (IV))

The cost for 60” diameter wellbore 8,000 feet deep might cost about \$16,000,000.
24 wellbore x \$4M = **\$384,000,000.**

Binary Power Unit of 4 MW might cost about \$100,000;
(Binary Power Unit of 4 MW is modest assumption.)

24 Binary Power Unit x \$100,000 = \$2,400,000;

The Control Center might cost about \$4,600,000;

The Mineral Extraction Facility might cost about \$10,000,000;

The potable water Pond might cost about \$5,000,000;

Piping system might cost about \$2,000,000;

A new Derrick might cost about \$10,000,000;

One Geothermal Power Plant might cost about **\$418,000,000.**

Three (3) Power Plant including final development of the drilling system might cost about **\$1,254,000,000.**

The new drilling system is more expensive at this earlier stage because of development cost, but in the long term, it would be better and less expensive solution.
Several initiating power plants on several sectors around the Salton Sea would be able to provide finance for subsequent power plants.

An analogy of this new drilling system in comparison to conventional drilling systems could be made - as comparison between new digital TV system and analog TV system that we switch from 15 years ago.

More power plants are built with the initial budget the faster we will proceed with subsequent power plants and the whole project, which final result will be more clean energy and more potable water.

It is realistic to conclude that Phases I – IV, would cost around \$15 billion dollars, (preferably less) with the final result of “really” saving the Salton Sea and providing conditions for tourism, clean energy, potable water, and prosperous economy.

2.2.1 Preliminary Estimate of Production Capacity of one Geothermal Power Plant:

Proposed Geothermal Power Plant(s) the “Scientific Geothermal Technology” consist of 24 well-bores and 24 Binary Power Units. Rough estimate for production capacity of one Power Unit is about 4 MWh.

24 “Binary Power Units” x 4 MW = 96 MWh; ~ 100 MWh;

2.2.2 Preliminary Estimate for Revenue of one Geothermal Power Plant:

Assumed price of \$60 per MWh;

\$60 x 96 MWh = \$5,760 per hour;

\$5,760 x 24h = \$138,240 per day;

\$138,240 x 365 days = \$50,457,600 per year;

3. Preliminary Estimate for Extraction of Lithium from water of the Salton Sea:

Salton Sea Facts:

Surface: 350 square miles (910 km²).

Inflow: < 1,200,000 acre-feet (1.5km³).

Depth: 43 feet (13 m).

Volume: 6,000,000 acre-feet (74 km³).

Salinity: 56 grams per liter.

[Pacific Ocean is: 35 gm /L].

Salt concentration has been increasing per year 3%.

About 4,000,000 Tons of salt are deposited in the Valley (Salton Sea) each year with irrigation water.

1,000,000 acre-feet = 1,233,481,837.54 Kiloliters (Kl).

1,233,481,837.54 Kiloliters (Kl) = 1,213,746,128 Tons.

1,213,746,128 Tons ÷ 5,000,000 = 242.75 Tons of Lithium.

Import of 1,000,000 acre-feet of seawater from Route #1 (Gulf of California - San Felipe) brings about **242.75 Tons of Lithium per year.**

Import of 2,000,000 acre-feet of seawater from Route # 2 (Pacific Ocean - Long Beach brings about **485 Tons of Lithium per year**.

Import of 242.75 Tons of Lithium from Route #1 (+) 485 Tons of Lithium from Route #2 - it sums up to **727.75 Tons** of Lithium per year.

Since the water of the Salton Sea is about 50% saltier than the water from the Ocean it is realistic to expect that about **1000 Tons of Lithium per year** can be extracted from the Salton Sea.

Economical lithium-source brine (lithium chloride) normally contains anywhere from a few hundred parts per million of lithium to upward of 7,000 ppm.

Sea water is a very poor source for the extraction of Lithium because the lithium concentration of sea water is about 0.2 parts per million (e.g., recovery of 1 ton of lithium requires treating 5 million tons of water).

Increasing concentration of brine by inducing evaporation inside the “Mineral Extraction Building” which function as a “Green House” and in process condensing vapor as water – a free byproduct. By repeating the process of adding salty brine into “evaporation tray” and inducing evaporation – it increases concentration of brine in the “evaporation tray”. This process does not need expensive electric energy. The evaporation is induced by hot pipes positioned underneath the “evaporation tray” (See Figs. 11-13).

The price of Lithium per metric ton as of 2019 is: \$13,000. Lithium price is expected to rise.

Estimated revenue from extracted lithium from salty water from the Salton Sea:

1000 Tons x \$13,000 = **\$13,000,000** per year.

4. SUMMARY:

The Cost of One Geothermal Power Plant: **\$418,000,000**.

The Cost of 3 Power Plant: **\$1,254,000,000**.

(Estimate of Production Capacity of one (1) Geothermal Power Plant: **100 MW**).

Estimate of Production Capacity of three (3) Geothermal Power Plant: **300 MW**.

(Preliminary Estimate for Revenue of one (1) Geothermal Power Plant: **\$50,457,600** per year).

Preliminary Estimate for Revenue of three (3) Geothermal Power Plant: **\$151,372,800** per year.

Estimate for Extraction of Lithium from the water of the Salton Sea: **\$13,000,000** per year.

Preliminary Cost/Revenue Estimate – Spreadsheet

(Segment V)

(System for Drilling and Harnessing Geothermal Energy)

Description	Cost	Power	Revenue
Preliminary Cost Estimate for one Proposed Geothermal Power Plant	\$418,000,000.	96 MWh	\$50,457,600 per year
Preliminary Cost Estimate for three Proposed Geothermal Power Plant	\$1,254,000,000	288 MWh	\$151,372,800 per year
Maintenance for three Power Plants			-\$7,500,000
Σ	\$1,254,000,000	288 MWh	\$143,872,800

Preliminary Cost/Revenue Estimate – Spreadsheet

(Segment IV)

(Harnessing Lithium from the Salton Sea)

Description	Tons	Price	Revenue
Preliminary Estimate for Extraction of Lithium from water of the Salton Sea	1,000 per year	\$13,000 per tone	\$13,000,000 per year

5. DISCLOSURE - ILLUSTRATIONS OF THE SYSTEM FOR DRILLING DEEPER, AND WIDER WELLBORES. (SEGMENT III (V))

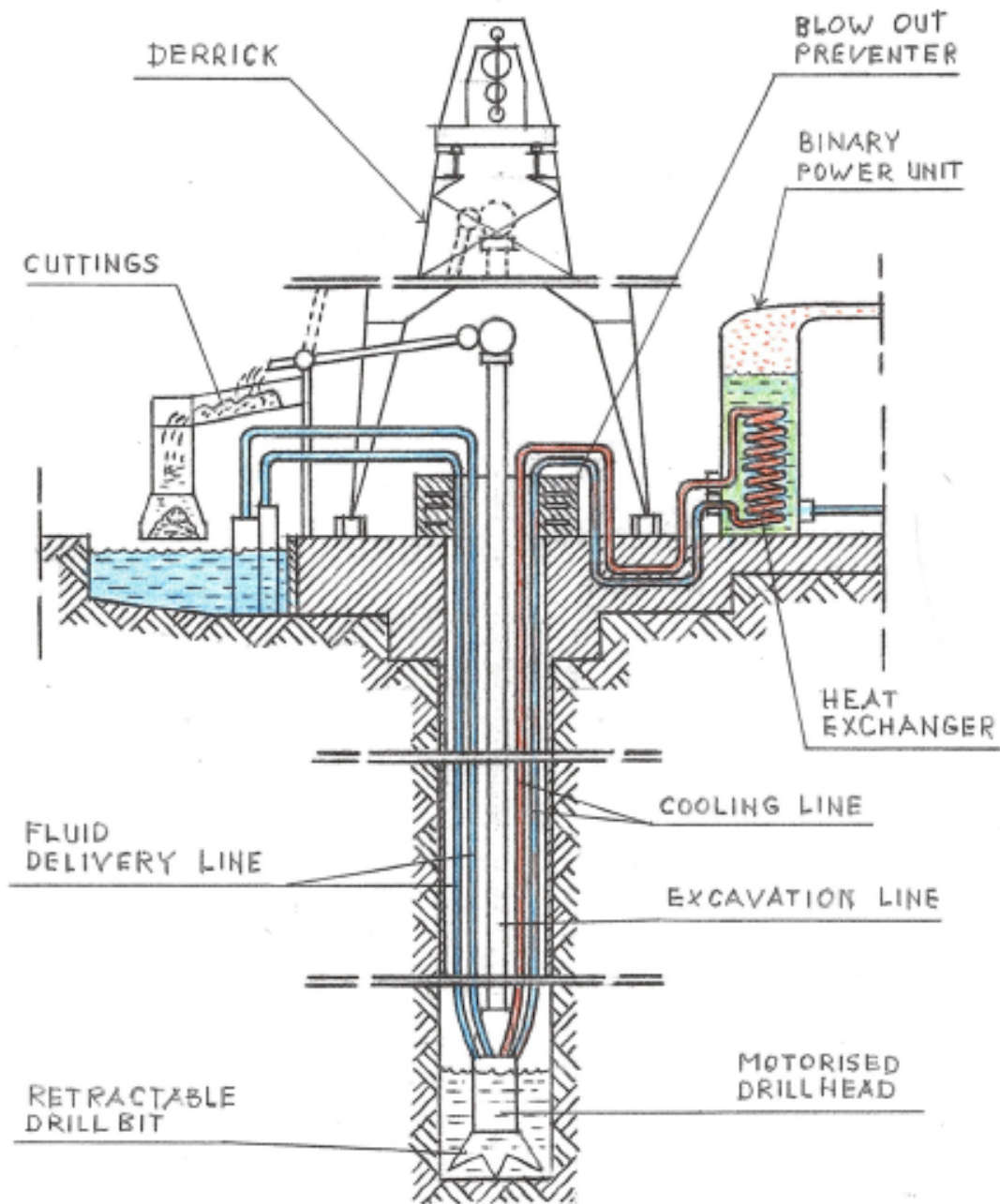

FIG. 1 - Schematic view of an apparatus for drilling faster, deeper, and wider wellbore.

Segment (III)

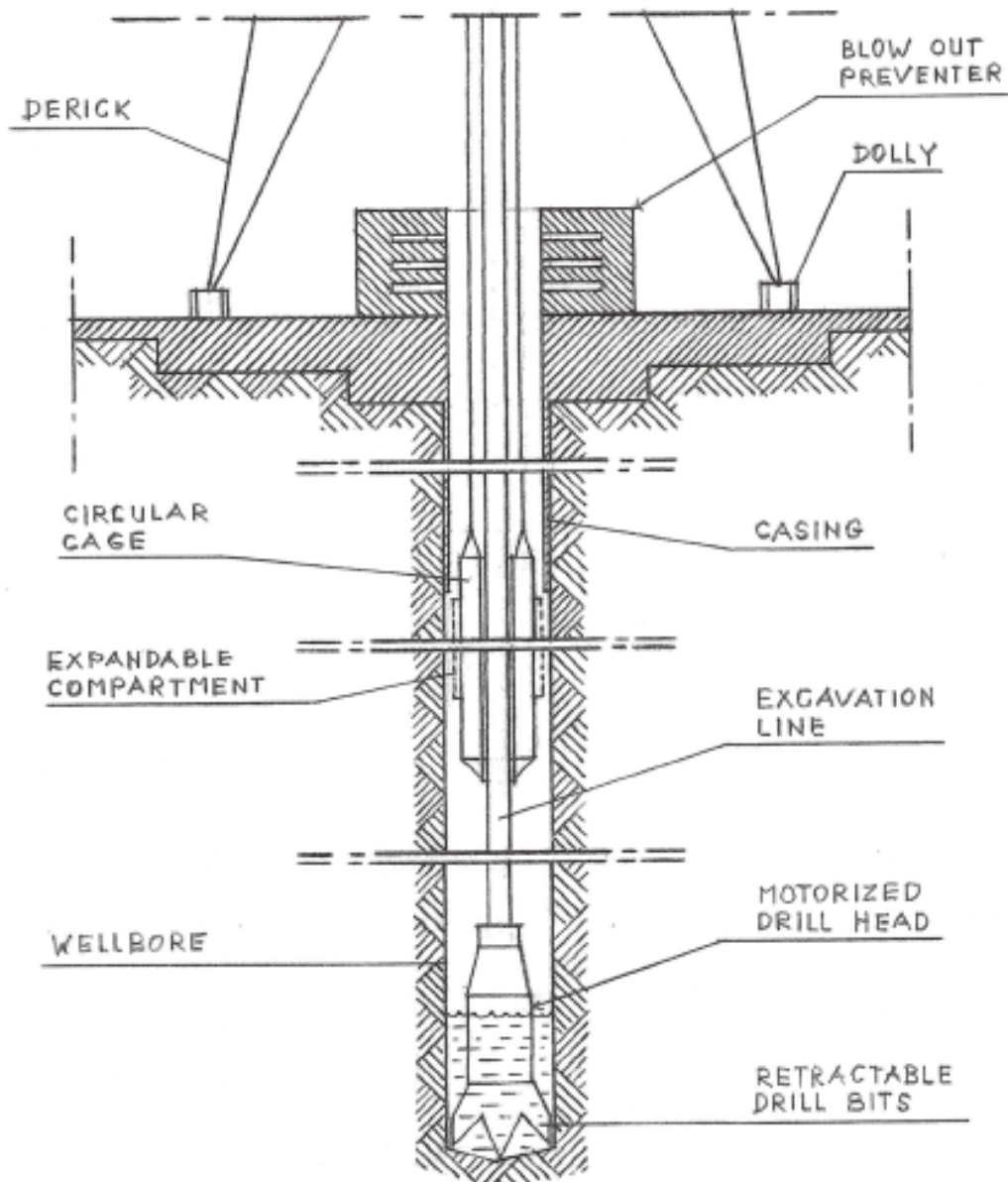

FIG. 2 - Schematic view of an apparatus for drilling faster, deeper, and wider wellbore with cage for casing.

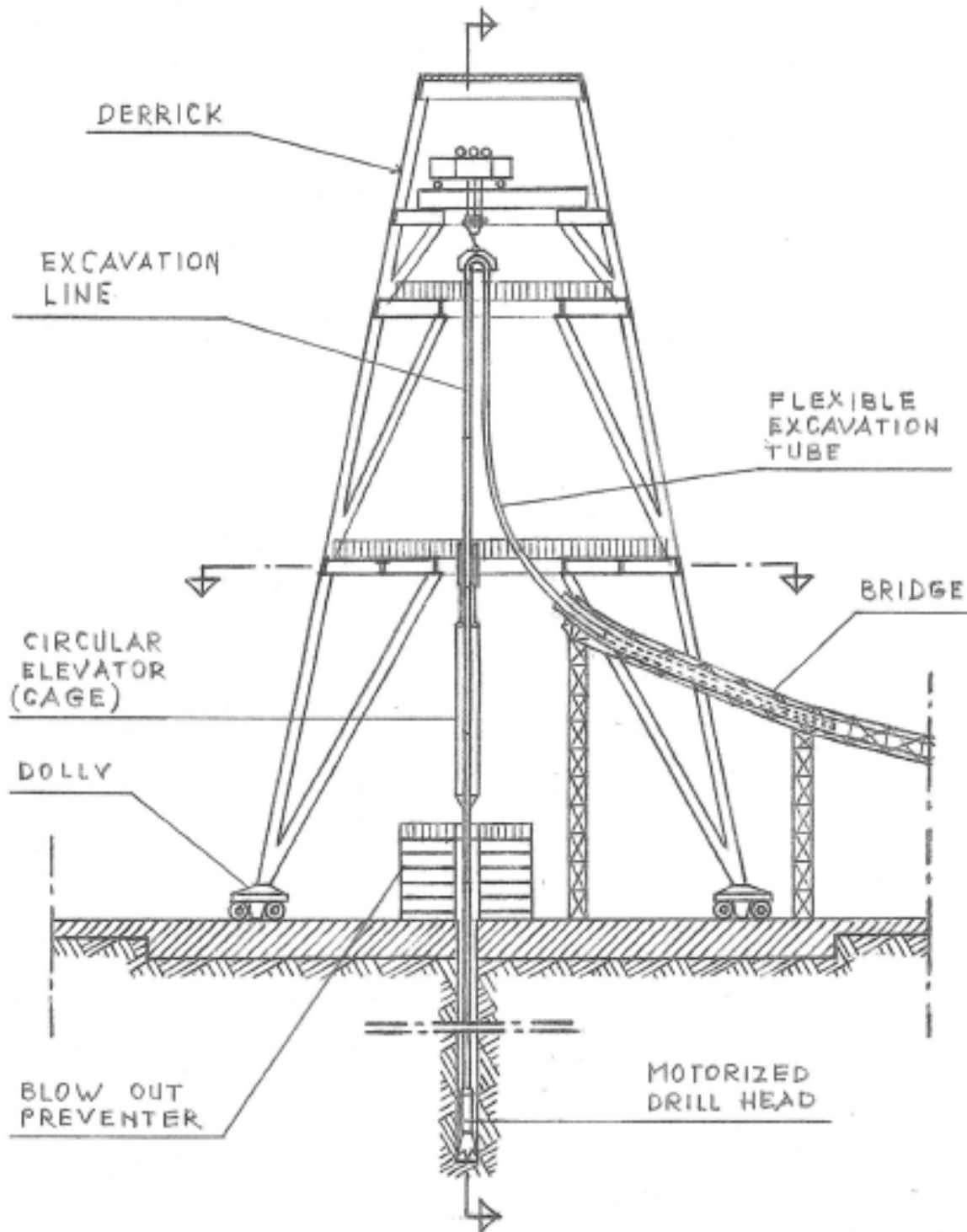

FIG. 3 - Another schematic view of an apparatus for drilling faster, deeper and wider wellbore with cage for casing.

Segment (III)

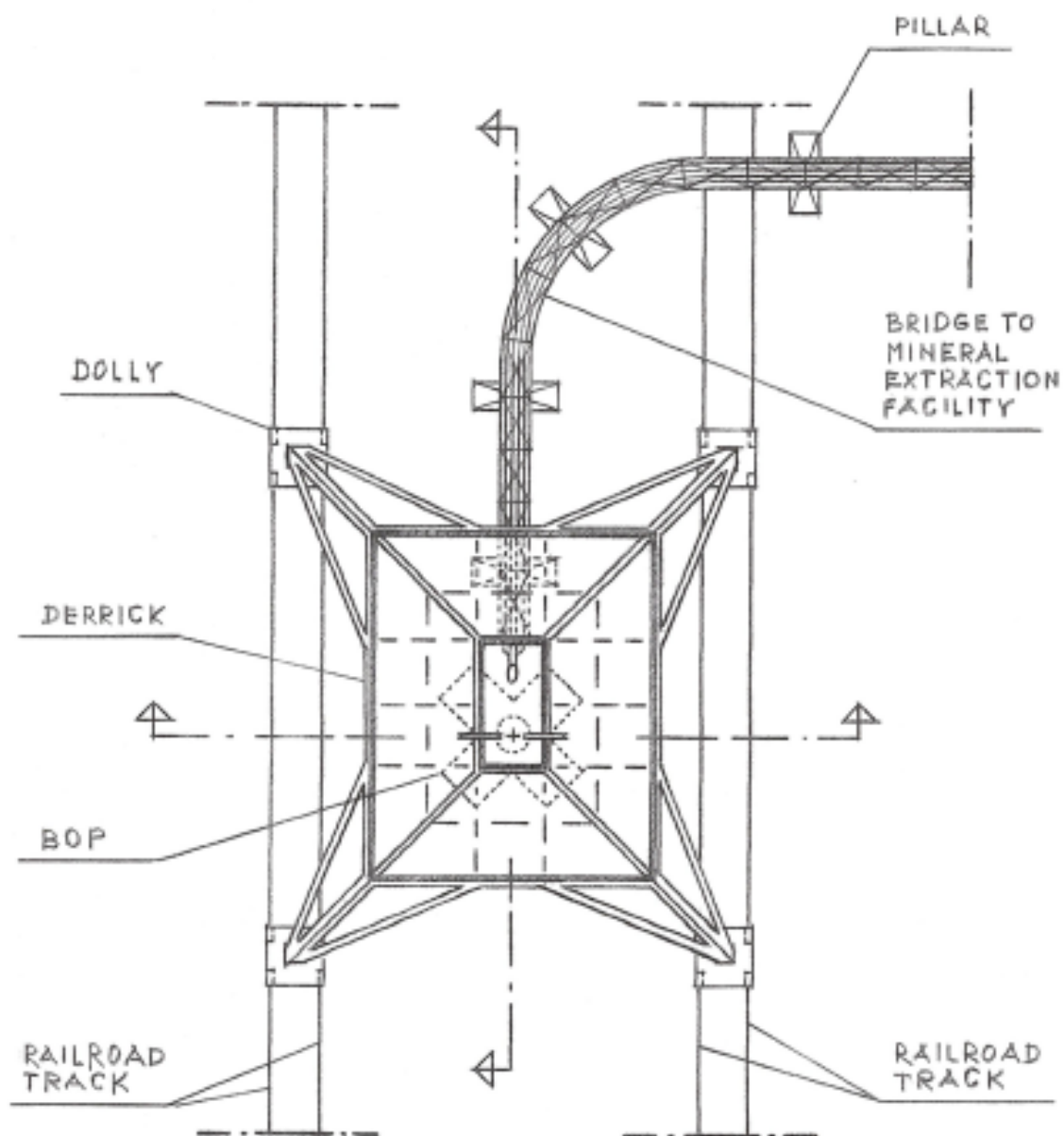

FIG. 4 - Plain cross-sectional view of an apparatus for drilling faster, deeper and wider wellbore.

Segment (III)

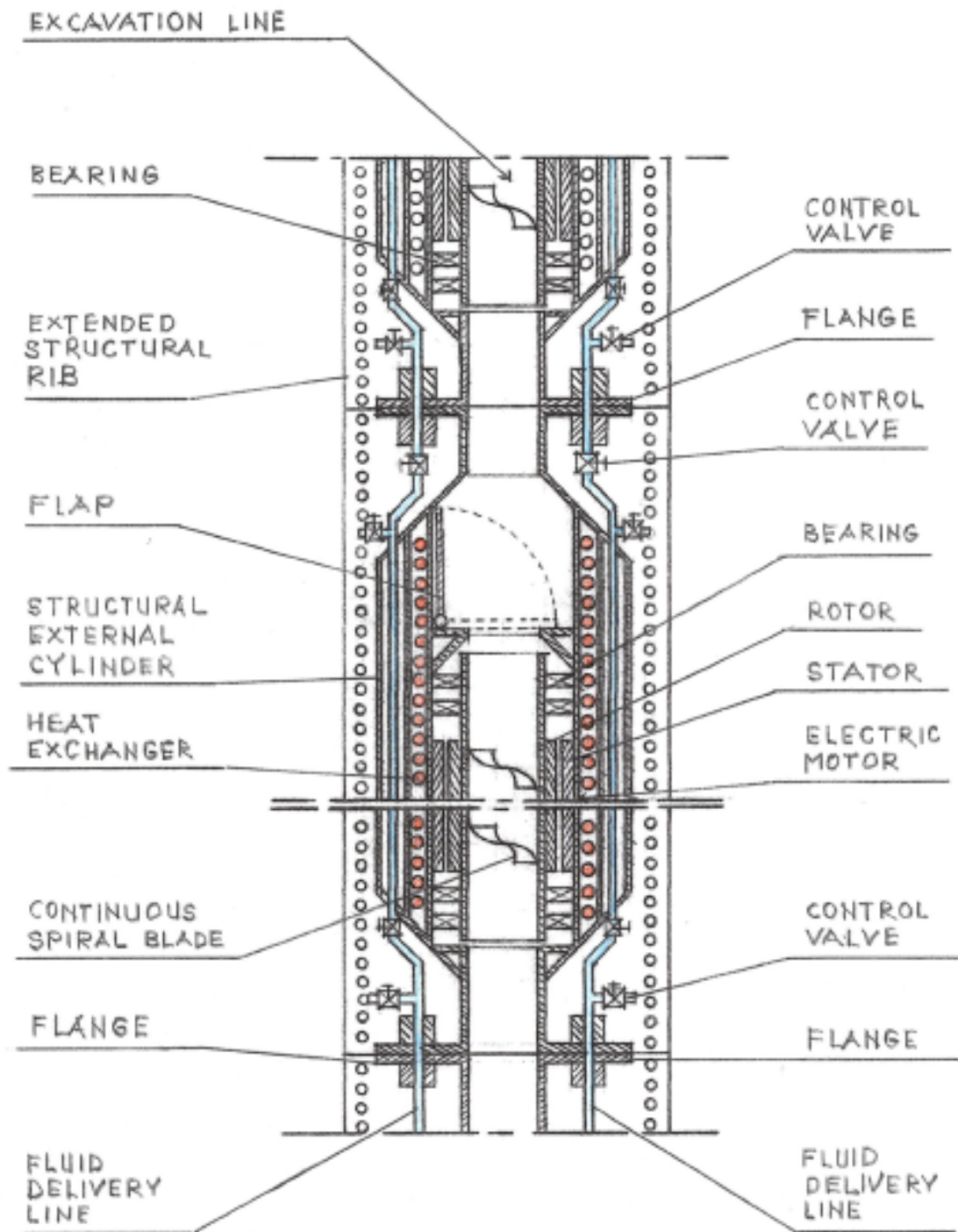

FIG. 5 - Cross-sectional view of an excavation line of the apparatus for drilling faster, deeper, and wider wellbore.

Segment (III)

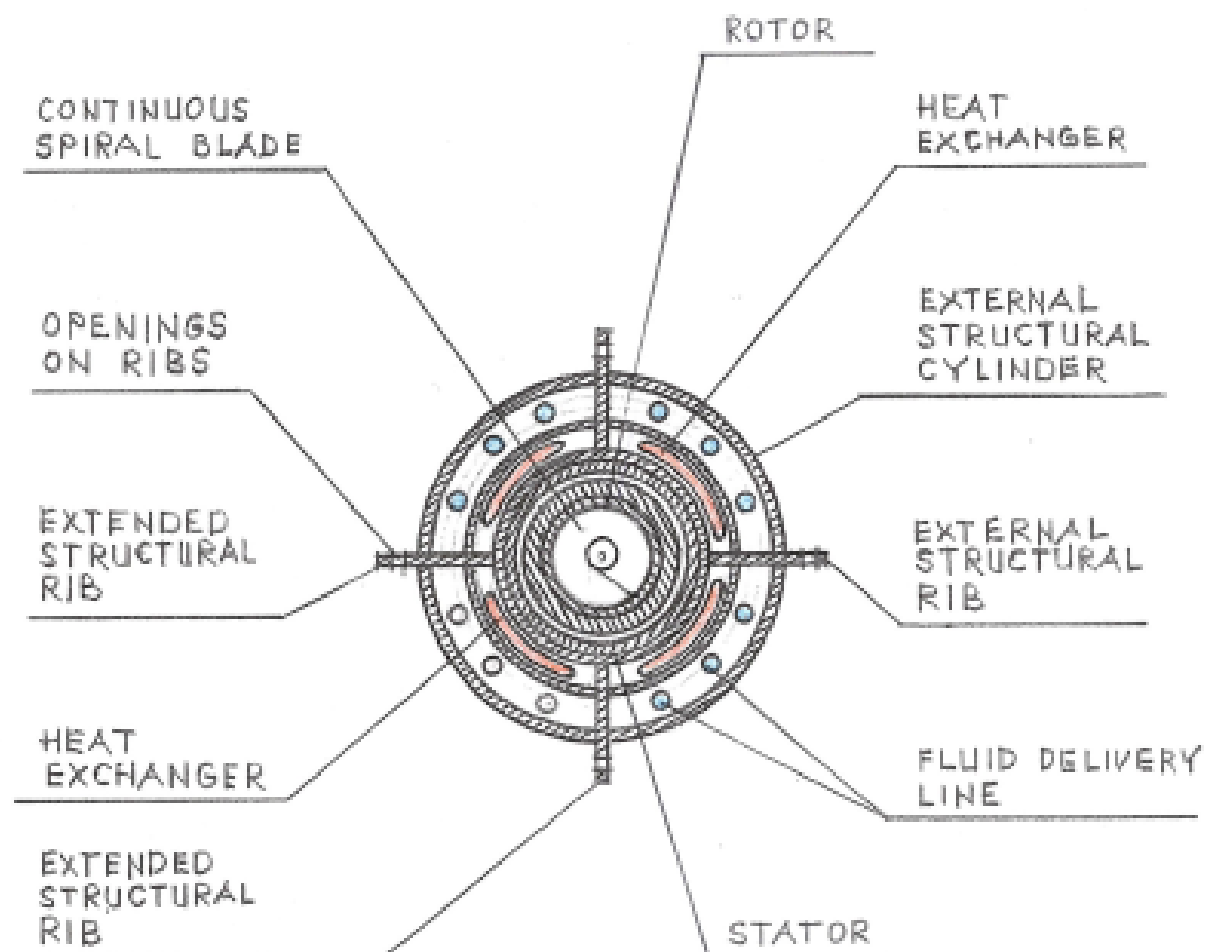

FIG. 6 - Cross-sectional view of an excavation line of the apparatus for drilling faster, deeper, and wider wellbore.

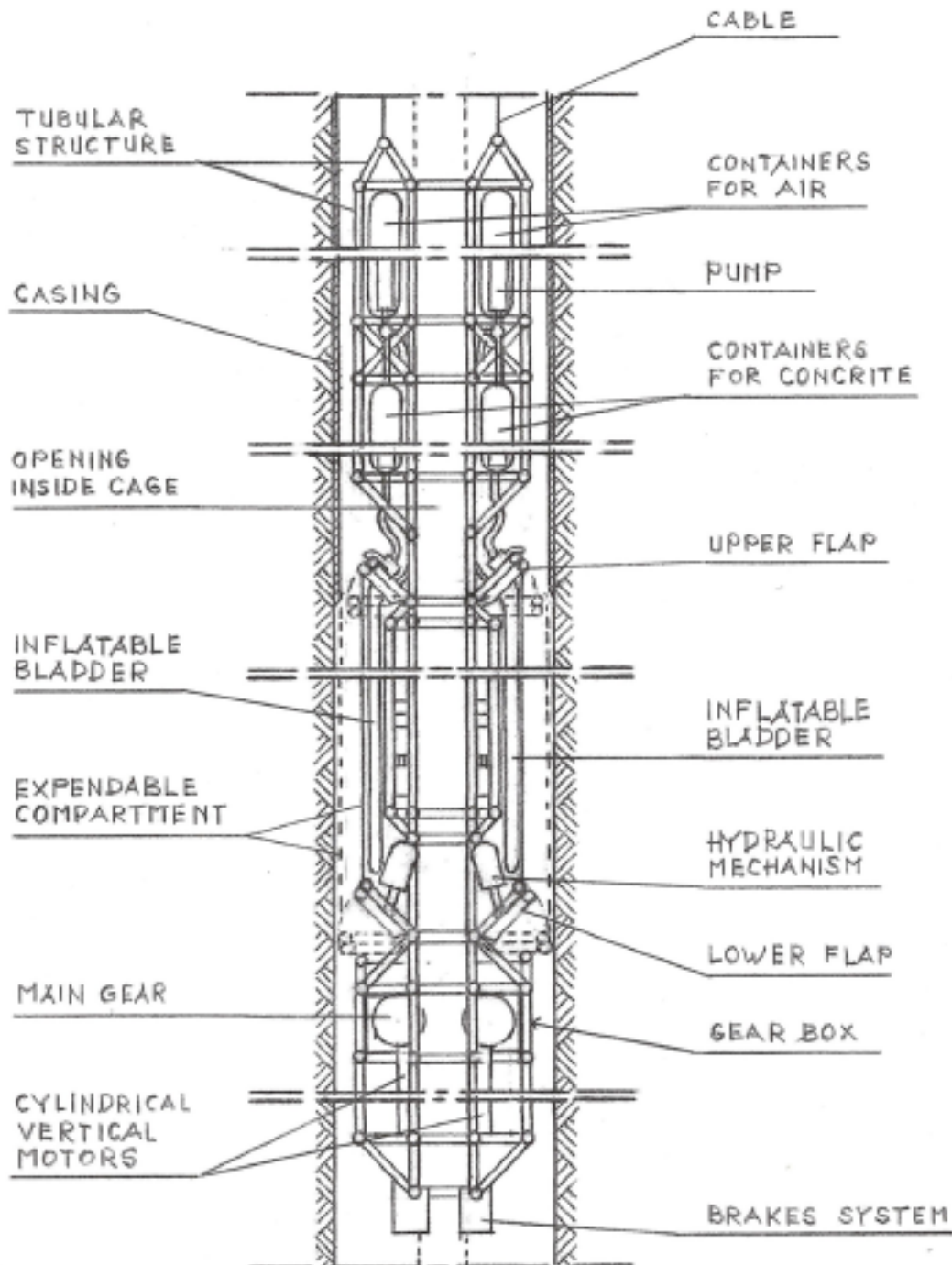

FIG. 7 - Cross-sectional view of a circular cage to be assembled on the excavation line of the apparatus for drilling faster, deeper, and wider wellbore.

Segment (III)

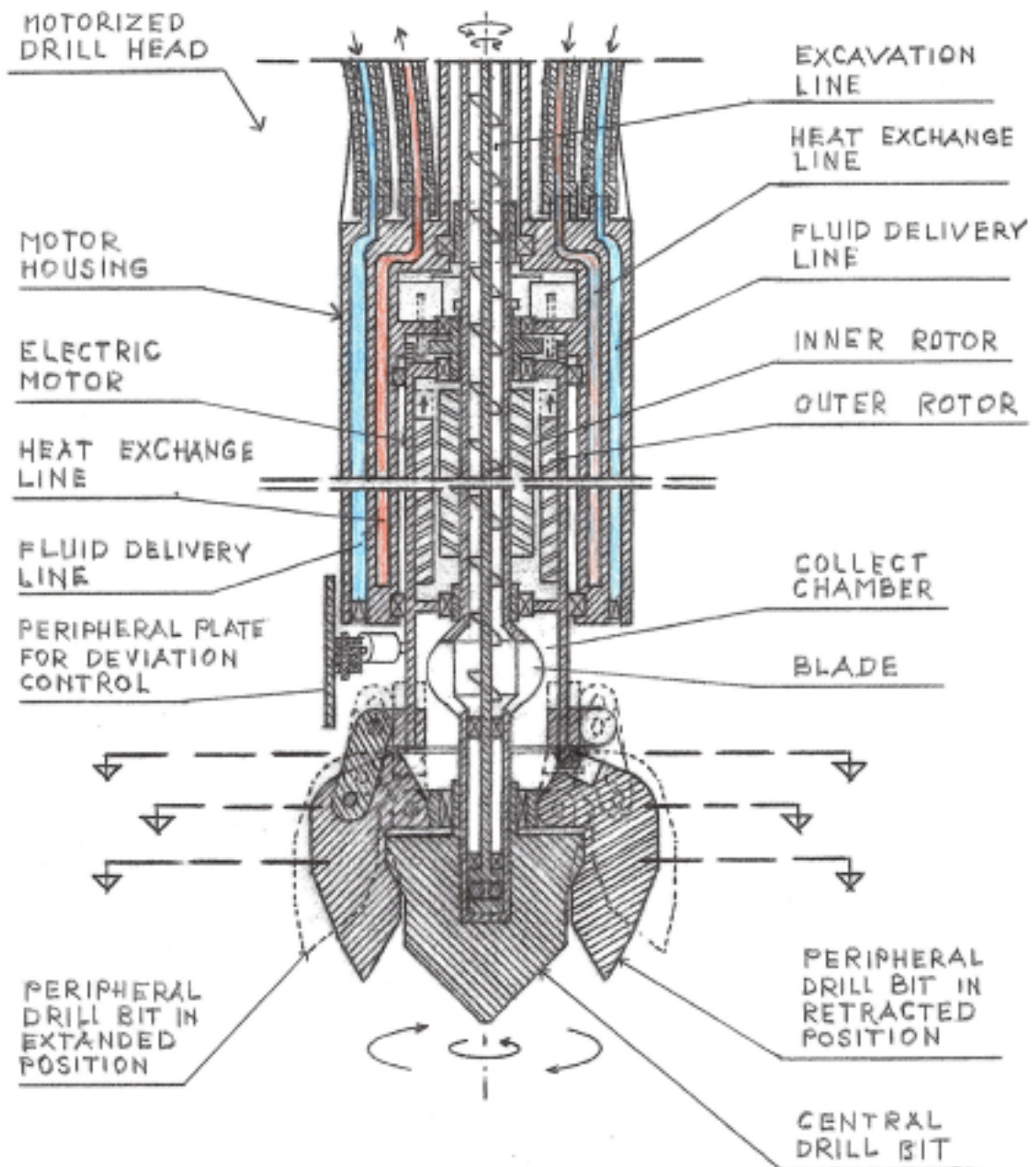

Figure 8 - Cross-sectional view of the motorized drill for drilling faster, deeper, and wider wellbore.

3. CONCLUSION

The essence of the presented methodology is that the presented proposal provides a solution for drilling deeper and wider wellbores. Also, the system provides a solution for drilling wellbores and building the casing at the same time. Also, the system provides a solution for drilling wellbores with constant diameter without having a reduction of the diameter.

Also, the essence of the presented methodology is having permanent motorized drill-head with retractable drill-bits at the bottom of the drilling apparatus moving whole apparatus deeper, as needed, in search for higher temperatures and transferring heat from heat sources to the power units on the ground surface with completely closed-loop systems.

Also, the essence of the presented methodology is having motorized excavation line.

Although the presented system is a part of geothermal power plant designed to include the local condition of the Salton Sea area to generate electricity, to generate potable water and to generate the brine which can be used for the extraction of lithium the presented system is not limited to this application

SUMMARY:

The Cost of One Geothermal Power Plant: **\$418,000,000.**

The Cost of three (3) **Power Plant: \$1,254,000,000.**

Energy generated: **300 MW.**

Preliminary Estimate for Revenue of one Geothermal Power Plant: **\$50,457,600** per year.

Estimate for Extraction of Lithium from the water of the Salton Sea: **\$13,000,000** per year

REFERENCES

U.S. Patent No. 7,849,690; Entitled: "Self-Contained In-Ground Geothermal Generators" (SCI-GGG); Issued on Dec.14, 2010;

U.S. Patent No. 8,281,591; Entitled: "Self-Contained In-Ground Geothermal Generators" (SCI-GGG); Issued on October 9, 2012;

U.S. Patent No. 8,713,940; Entitled: "Self-Contained In-Ground Geothermal Generators"; Issued on May 6, 2014;

U.S. Patent No. 9,206,650; Entitled: "Apparatus for Drilling Faster and Wider Wellbore; Issued on December 8, 2015;

U.S. Patent No. 9,978,466; Entitled: "Self-Contained In-Ground Geothermal Generator and Heat Exchanger with In-Line Pump; Issued on May 22, 2018;

U.S. Patent No. 9,982,513; Entitled: "Apparatus for Drilling Faster and Wider Wellbore with Casing; Issued on: May 29, 2018;

U.S. Patent No. 9,995,286; Entitled: "Self-Contained In-Ground Geothermal Generator and Heat Exchanger with In-Line Pump and Several Alternative Applications; Issued on: June 12, 2018;

U.S. Patent No. 11,098,926; Entitled: "Self-Contained In-Ground Geothermal Generator and Heat Exchanger with In-Line Pump used in Several Alternative Applications including the Restoration of the Salton Sea. Issued on August 24, 2021;

Several patent-pending applications.