

DOCKETED

Docket Number:	20-RENEW-01
Project Title:	School Energy Efficiency Stimulus Program
TN #:	237749
Document Title:	Justine Burt Comments - accelerate solar microgrid installation in K12 schools
Description:	N/A
Filer:	System
Organization:	Justine Burt
Submitter Role:	Public
Submission Date:	5/7/2021 3:02:36 PM
Docketed Date:	5/7/2021

*Comment Received From: Justine Burt
Submitted On: 5/7/2021
Docket Number: 20-RENEW-01*

accelerate solar microgrid installation in K12 schools

Solar emergency microgrids with solar photovoltaics, energy storage, and monitoring, communications, and controls are proven technologies that offer multiple long-term benefits for school districts and attractive returns for investors. California has 10,588 K-12 schools in 1,037 school districts. Each year a few schools add solar microgrids, which provide clean power, allow the school district to take advantage of lower energy rates at different times of the day, and provide resilience benefits. To accelerate the adoption of solar microgrids, I would like to see standardization of the RFP process. Each school district should not have to start from scratch figuring out how to do feasibility studies, RFPs, and power purchase agreement contracts.

Additional submitted attachment is included below.

K-12 Solar Microgrid Catalyst Project

Toolkit for Communications, Technical, and Contract

Opportunity

- Communities in California are vulnerable to blackouts during wildfire season, seismic events, and other natural disasters
- Solar emergency microgrids with solar photovoltaics, energy storage, and monitoring, communications, and controls are proven technologies that offer multiple long-term benefits for school districts and attractive returns for investors
- Each K-12 school can provide emergency shelter to the neighborhood and host emergency communications activities during a disaster when a solar microgrid is in place
- Microgrid designs are tailored to each school's unique needs
- The process and level of effort -- of setting goals and collecting data for a solar microgrid, conducting a feasibility study, designing, developing an RFP, power purchase agreement, and operations and maintenance contract -- can be streamlined to save each school district time and money.

"We have raised \$1 trillion for climate solutions but have only invested \$300 billion. We need more shovel-ready projects to invest in."

Jigar Shah,
former President,
Generate Capital,
current Director of
Loan Program,
Dept of Energy

Solutions

- Catalyze the retrofit of half of all 10,588 K-12 schools in California with solar emergency microgrids by 2030
- Create and disseminate a toolkit that includes:
 - Communications tools that define solar microgrids, explain benefits, and share case studies
 - Guidance for solar microgrid system goal setting for district
 - Online data collection tools
 - Standardized solar microgrid configurations
 - Standardized feasibility study guidance
 - Pro-forma set of design-build-own-operate RFP templates
 - Standardized solar power purchase agreement templates

Solar microgrid configuration

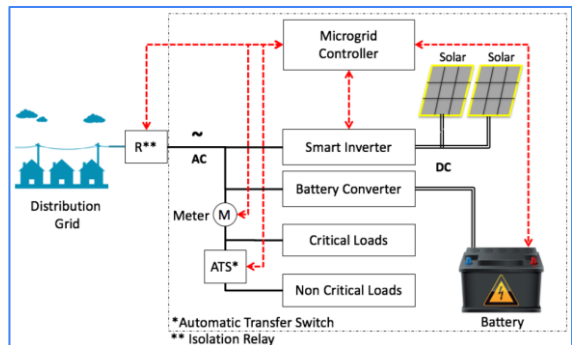

Tiered loads for solar microgrids

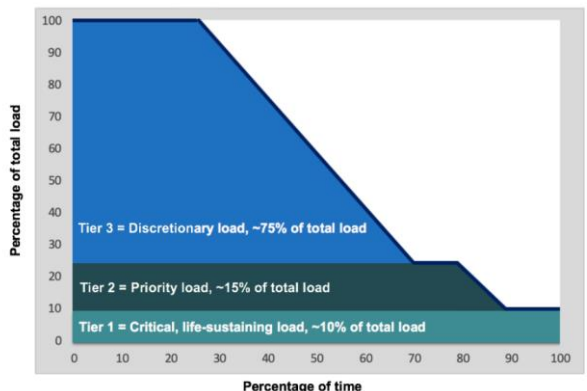

Project Team

Project team expertise												
Roles	Project management	Business development	Marketing	Communications	Technical - solar microgrid	Professional engineer	Request for proposals	Construction	K-12 school districts	Utilities	Contracts	Finance
Project manager	*	*				*					*	*
Marketing & communications	*	*	*	*		*			*		*	
Microgrid lead		*			*	*				*	*	
Microgrid engineer				*	*		*		*	*	*	
Utilities engineer	*				*	*				*	*	
K-12 green vocational lead	*						*	*				
Construction manager	*						*	*			*	
Legal											*	*
Finance											*	*

Project Phases

Phase I: Communication tools

- Convene stakeholders
- Define solar microgrids, explain benefits, share case studies
- Facilitate goal setting

Deliverables: PowerPoint, one double-sided overview including three K-12 solar microgrid case studies, written highlights of process and final goals set

Phase II: Technical tools

- Standardize three different solar microgrid configurations
- Create templates for data collection

Deliverables: Microgrid configurations, online data collection templates

Phase III: Contract tools

- Template for Feasibility Study
- Template for Requests for Proposal
- Template for Solar Power Purchase Agreement
- Template for Operations and Maintenance Contract

Deliverables: feasibility study, RFP, SPPA, O&M contract templates

Questions? Contact Justine@appraccel.com