

DOCKETED

Docket Number:	19-SPPE-03
Project Title:	Sequoia Data Center
TN #:	233084
Document Title:	CEC Staff ROC with SVP regarding reliability of system
Description:	N/A
Filer:	Scott Galati
Organization:	DayZenLLC
Submitter Role:	Applicant Representative
Submission Date:	5/22/2020 9:26:33 AM
Docketed Date:	5/22/2020

DOCKETED

Docket Number:	19-SPPE-01
Project Title:	Laurelwood Data Center (MECP I Santa Clara I, LLC)
TN #:	229381
Document Title:	ROC with SVP Laurelwood Data Center
Description:	Record of Conversation from Silicon Valley Power-response to questions on 7_2_19 (TN229077)
Filer:	Susan Fleming
Organization:	Energy Commission
Submitter Role:	Public Agency
Submission Date:	8/13/2019 9:45:04 AM
Docketed Date:	8/13/2019

CALIFORNIA ENERGY COMMISSION
REPORT OF CONVERSATION Page 1 of 1



**Siting, Transmission
 and Environmental
 Protection Division**

FILE: n/a

PROJECT TITLE: Laurelwood Data Center **Docket:** 19-SPPE-01

TECHNICAL AREA(s): Air Quality

Telephone Email Meeting Location:

NAME(s): Mark Hesters, Senior Transmission Planner **DATE:** 8/2/19, 8/8/19 **TIME:** 2:23pm, 2:23pm

WITH: Kevin Kolnowski, Assistant Director, SVP

SUBJECT: Siliocon Valley Power (SVP) Responses to Questions from Staff

COMMENTS:

On August 2, 2019, Mark Hesters, Senior Transmission Planner with the California Energy Commission received responses from Kevin Kolnowski, Assistant Director with Silicon Valley Power to Energy Commission staff's questions on 7/2/19 (TN 229077).

The following attachments are the responses received via email from Kevin Kolnowski with SVP. The email noted that the information provided is how our system is currently configured, not how it will be in the future.

On August 5, 2019, Staff sent several additional questions to SVP after reviewing SVPs response to staff's original questions. The additional questions and SVPs responses are attached.

CC:	Signed: s  s 
	Name: Mark Hesters, Senior Transmission Planner Lisa Worrall, Planner II

Outlined below are the City of Santa Clara's Silicon Valley Power's (SVP) responses to the California Energy Commission's (CEC) Mark Hesters request of July 2nd, 2019 for information related the proposed Laurelwood Substation and SVP's system design.

1. Please provide for the 60 kV loop on the SVP system that will serve the Laurelwood data center:

- a. A physical description

Laurelwood Substation is a three-50MVA (60kV:12kV) transformer bank substation on SVP's 60kv South Loop. It is located between our 115kV Kifer Receiving Station (KRS), and 60kV substation, CCA. Each Transformer has a rating of 30/40/50 MVA, IEEE max temperature rise of 65 C, increases the capability by 10% or 33/44/56 MVA. The final buildout of Laurelwood substation will have a capability of 100 MVA, with 150 MVA of installed capacity which increases its reliability. Laurelwood Substation Single Line Diagram XXX-E-0-X-1 is attached.

- b. The interconnection points to SVP service

The Interconnection points to SVP will be the three low-side transformer gang switches currently drafted as GS30, GS20, and GS10.

- c. The breakers and isolation devices and use protocols

There are four 60kV Breakers at Laurelwood, CB12, CB22, CB32 and CB42 which will enable various isolation schemes to insure a transformer bank can be isolated while the other two transformers remain in service. The system is designed such that one of the transformers can be taken out of service for repairs or maintenance while the other two can fully support customer load.

- d. A list of other connected loads and type of industrial customers

See attached Excel Spreadsheet, Loop Customer and Loading Peak 8-1-19.xlsx

- e. A written description of the redundant features that allow the system to provide continuous service during maintenance and fault conditions

SVP's South Loop is fed from the Kifer Receiving Station (KRS) and Scott Receiving Station (SRS). Both KRS and SRS are 115/60 kV receiving stations. SRS is connected to SVP's Northern Receiving Station (NRS) with two feeds and the Duane Substation (DUA). KRS is connected to our Duane (DUA) Substation and PG&E's Newark Substation (NEW) and PG&E's FMC Substation. These connections are at 115kV. The DUA Substation is connected to the City's 147 MW Donald Von Raesfeld Combined Cycle Power Plant. Both SRS and KRS

have two 115/60kV transformers for redundancy and reliability. This arrangement allows for a high reliability electrical system.

The 60kV loop is designed to maintain power to all customers when any line on the loop is out of service due to either maintenance or an unplanned outage. Each Receiving Station on the loop ends, SRS and KRS, is capable of delivering power to the entire loop. The full redundancy design of the system allows any line segment on the loop to be taken out of service for regular maintenance activities without causing a service interruption to any customers. Additionally, the protection systems on the loop are designed to detect fault conditions and isolate the fault to a single line segment. The isolation of the fault allows for continuous service for all customers during fault conditions.

As discussed above, the Laurelwood substation will have three 30/40/50 MVA transformers. The maximum load being requested by the customer is 100 MVA. With 150MVA of transformers, one transformer can be removed from service for maintenance and the load can be provided by the remaining two transformers.

See attached SVP Network Diagram 8-2-19.

2. Please provide a description of the SVP system in general and the other 60 kV loops that would serve data centers.
 - a. Could you provide a one-line diagram and a "*.shp" file of the 60 kV and above lines serving the Silicon Valley Power System? Would you have any concerns with us using either of these in a public document?

See Attached Diagram SVP CA Energy Map 8-2-19 and the SVP Network Diagram

- b. Are each of the 60 kV loops designed similarly or do some of them have features that make them more or less reliable than the others?

They are all designed similarly with the same redundancy/reliability philosophy.

3. Please describe any outages or service interruptions on the 60 kV systems that will serve the proposed data centers:
 - a. How many 60 kV double looped lines serve data centers in SVP, and how many data centers are on each?

The City currently has five 60kV Loops. They are as follows:

- East Loop
- Northeast Loop
- Northwest Loop
- Center Loop
- South Loop

Customer location per loop is provided in Question 1 d. above.

The City is currently in design phase of expanding the East Loop to shift load from the South Loop to East Loop and expand system capacity. The East Loop and South Loop will continue to maintain double looped lines serving each substation both before and after completion of this project. This project is expected to be completed by January of 2021.

- b. What is the frequency of 60 kV double-looped lines having a “double outage” that would require use of backup generators?

Extremely Rare. There was only one outage between years 2009 current 2019 where SVP lost both 60kV feeds into a substation. The total duration of the outage was 7 hours and 23 min for the outage that occurred on May 28th, 2016 at 9:28 PM.

A balloon released by an individual made contact with the 60kV line between the Northwestern Substation (NWN) and the Zeno Substation (ZEN) at pole NWZ4. The balloon contact caused a pole fire and the bottom phase, bottom insulator and guy wire burned. The circuit breaker at ZEN substation tripped properly, isolating the fault from the ZEN substation and keeping the line from the ZEN substation to the Kiefer Receiving Station energized.

However, on the NWN Substation side, the circuit breaker failed to trip due to a faulty direct current (DC) voltage source which is required for the breaker tripping coil.

Once this breaker failed to open, due to the directional nature of the fault, the fault was picked up at the Scott Receiving Station (SRS) which caused the section of the loop from the ZEN to SRS to be without power. This included the NWN Substation and the Fairview (FVR) substation. Since this was an unusual event, SVP spent the required time determining the root cause and inspecting the system prior to re-energization.

- c. How long were any outages and what were their causes?

60kV outage data since 2009 is in the below chart (10 years of data). The items highlighted in yellow indicate that there was some kind of fault associated with the outage. The items highlighted in blue is when we had customers out of power as a result. The non-highlighted items are where an outage was taken to correct an observed situation.

From 2009 through current 2019 there have been:

1. 15-60kV impacted outages due to faults.
2. 4- 60 kV impacted outages that caused customers to be out of power. Only the 12/2/16 outage and 5/28/16 involved data centers.
3. 31- 60kV total outages
4. The average 60kv outage lasts for 2.75 hours

Date	Line(s)	Cause	Duration	Customers out of power
3/30/19	URA-WAL	Bird @ UW43	1 Hour 46 Min	0
11/22/18	HOM-SER	Pole Fire HS9 (force out)	1 Hour 27 Min	0
7/5/18	SER-HOM	Force out to remove balloons	9 Min	0
5/5/18	SER-HOM	Force out to remove balloons	11 Min	0
9/1/17	AGN-NAJ	Force out to cut trees	1 hour 5 min	0
8/8/17	URA-ZEN	Force out to remove balloons	20 Min	0
5/25/17	SRS-FRV	Tripped during SCADA commissioning	1 Min	0
5/8/17	NWN-ZEN	Force out to remove bird	50 Min	0
4/29/17	SRS-HOM	Force out to remove balloons	2 hours 22 min	0
03/20/17	JUL-CEN	Third Party got into 60kV	9 hours 55 min	0
01/22/17	SER-BRO	Tree in wires	3 hours 31 min	0
01/22/17	NAJ-PLM	A phase contact guy wire when winds pick up	1 hour 47 min	0
01/19/17	KRS-PLM	Palm frond between phases	41 min	0
01/18/17	NAJ-PLM	A phase contact guy wire when winds pick up	1 Hour 44 min	0
12/02/16	RAY T1 & T2	Dropped both transformers during restoration switching due to relay not reset	12 minutes	257
09/06/16	SRS-CEN	Bird Contact	40 Min	0
06/30/16	WAL-FIB	Bird nest contact	12 hours and 4 min	0
5/28/16	SRS-FRV-NWN-	Balloons in line and	7 hours 23 min	28

	ZEN	breaker fail		
02/17/16	SRS-FRV	Palm tree with fire	7 hours	0
11/18/15	SER-BRO	Arcing wires forced	2 hours 59 min	0
11/16/15	SER-BRO	Rotten Pole- forced	22 hours 32 min	0
11/09/15	JUL CB32	Possible lightning	53 min	0
10/29/15	SER-BRO	Roller arcing-forced	3 hours 33 min	0
08/12/15	BRO-DCJ, BRO T1	Squirrel on CB100	3 hours 55 min	2155
06/24/15	CCA CB22	Bad JMUX card	3 hours 23 min	0
05/30/15	SER-BRO	No cause found	3 hours 12 min	0
03/31/15	BRO-DCJ 12KV BUS 1 & 2	Squirrel across 12kv bus tie	3 hours 26 min	2927
01/28/15	Mission CB12	Shorted control cable	6 hours 29 min	0
04/24/14	DCJ CB42	Tripped during relay work. BF wired as TT	1 Hour 30 Min	0
10/14/13	URA_WAL	Sheared Hydrant hit 60kV above	2 hours 26 min	0
12/06/12	Jul CB 32	Tripped due to cabinet vibration	2 min	0

- d. Have there been any changes to the SVP system that would prevent these types of outages from occurring in the future?

Every outage is analyzed for root cause. Most of the outages that occur on the 60kV system are outside SVP's control, e.g. Mylar balloon, squirrels or animals, car accidents, and similar events. If the outage is suspected to be caused by a failure of the intended protection scheme or equipment, then further analysis is performed and appropriate changes are implemented to minimize impact of future outages. After the outage in May, 2016, SVP performed additional circuit breaker testing and DC wire checks to maintain the reliability of its system.

- e. Given the large number of data centers with backup generators being developed in the SVP service area, would future outages likely affect more than one data center or are there elements of the SVP system design that might limit the impact of transmission outages?

Adding more data centers on the 60kV looped system would not make it more or less likely that an outage will occur. A "double outage," which has occurred only once in the last ten years, has the potential to cause multiple data centers to go to back up generators depending on the locations of both line segments that are out of service.

- f. Are there data center customers served by SVP (ie, legacy data centers) that are not on the 60kV loops? How are they served and what are the expected service outage types and rates?

No, ALL data center customers are inherently part of our 60kV loop. The voltage level these data center customers are on our 12kV distribution system, which power is provided from our 60kV substations.

4. During the proceeding for the McClaren Backup Generating Facility, the project owner described a 5/29/2016 outage at their Vantage Santa Clara Campus. The project owner provided information that six backup generators operated during that outage; of those, two operated for 7 hours while four others operated approximately 19 hours.
- a. What was the reason for the outage?

Balloons made contact with the NWN-ZEN 60kV Line at Pole NWZ4. Original fault was A Phase and GRD due to contact with the Guy wire. NWN CB 32 failed to trip due to a bad DC power source to the breaker trip coil. FRV CB12 tripped as a result of NWN CB32 not tripping. FRV CB42 and SRS CB572 also tripped due to 3 phase differential fault that occurred which is believed to have been caused by the amount of time the A phase and ground fault lasted.

- b. How long did it last for the Vantage customer? For other customers on that loop?

The outage occurred on 5/28/2019 at 2128. On 5/29/19 @ 0429- Fairview was restored, @ 0434 NWN 60kV bus restored. The system outage was 7 hours and 23 minutes. We are not privileged to the information as to why the data center may have chosen to continue to operate on their back-up generators.

- c. Is there anything about the location or interconnection of the proposed data centers that protect against a similar outage?

No difference with this location.

- d. Does this description of one recent outage at the MECP1 Santa Clara 1, LLC seem to be a reasonable description of the event and applicable for the Laurelwood Data Center?

The description of the Vantage event is reasonable, however cannot be directly applied to the Laurelwood Data Center. The Vantage event had a unique combination of contributing factors for which the resulting outcome cannot be reasonably assumed to be the expected outcome for line faults on the SVP 60kV network.

5. Pacific Gas and Electric Company and other utilities have developed Public Safety Power Shutoff protocols that could disconnect electrical services during periods of concern in order to prevent their equipment from starting wildfires. These potential shutoffs could last hours or even days. How would these new protocols potentially affect SVP's service territory or access to bulk transmission assets?

The City of Santa Clara's SVP is not located in a California Public Utilities Commission/Cal Fire Tier 2 or Tier 3 high fire risk zone. Therefore, SVP does not have a Public Safety Power Shutoff as part of their Wildfire Mitigation Plan. However, we do receive power from PG&E through six interconnection points. Based on our discussion with PG&E, Santa Clara may be requested by PG&E or the California Independent System Operator (CAISO) to curtail load. This request may be because of the reduced capacity somewhere within the system which will require overall system load reduction. This experience may be similar to the energy crisis of the early 2000's when rolling black-outs were require to maintain electric grid reliability. SVP has the capability to provide 200 MW of generation in the City with its Donald Von Raesfeld Combined Cycle Power Plant (147 MW) and the Gianera Peaker Plant (49 MW) and Cogen Facility (6 MW), we may be requested to curtail load.

SVP is working with PG&E and the CAISO as to how this situation may occur.

Substation	Loop	Customer/Industry
Fairview	Center	Mfg1
Fairview	Center	Datacenter1
Fairview	Center	Datacenter2
Fairview	Center	Datacenter3
Fairview	Center	Datacenter4
FIB	Center	Mfg2
Lafayette	Center	Mfg3
Lafayette	Center	Datacenter5
Lafayette	Center	Mfg4
Lafayette	Center	Mfg5
Lafayette	Center	Datacenter6
Lafayette	Center	Mfg6
NWN	Center	Datacenter7
Uranium	Center	Datacenter8
Uranium	Center	R&D1
Uranium	Center	Property Management1
Uranium	Center	Datacenter9
Uranium	Center	Datacenter10
Uranium	Center	Datacenter11
Uranium	Center	Property Management2
Uranium	Center	Education1
Uranium	Center	Education2
Uranium	Center	Education3
Uranium	Center	Education4
Uranium	Center	Semiconductor/Telecommunications
Uranium	Center	Gaming/AI/Semiconductors1
Uranium	Center	R&D/Mfg
Uranium	Center	Mfg7
Walsh	Center	Semiconductor1
Walsh	Center	Gaming/AI/Semiconductors2
Walsh	Center	Mfg8
Walsh	Center	Gaming/AI/Semiconductors3
Walsh	Center	Datacenter12
Walsh	Center	Education5
Walsh	Center	Government1
Walsh	Center	Government2

Walsh	Center	Semiconductor2
Walsh	Center	Semiconductor/R&D/Mfg
Walsh	Center	Mfg9
Walsh	Center	Telecommunications1
Walsh	Center	Datacenter13
Walsh	Center	Education6
Walsh	Center	Datacenter14
Zeno	Center	Education7
Zeno	Center	Education8
Zeno	Center	Semiconductor3
Zeno	Center	Datacenter15
Zeno	Center	Bio Tech 1
Zeno	Center	Semiconductor/Telecommunications
Zeno	Center	Semiconductor/R&D/Mfg

Center 141MW
Mfg1
Datacenter1
Datacenter2
Datacenter3
Datacenter4
Mfg2
Mfg3
Datacenter5
Mfg4
Mfg5
Datacenter6
Mfg6
Datacenter7
Datacenter8
R&D1
Property Management1
Datacenter9
Datacenter10
Datacenter11
Property Management2
Education1
Education2
Education3
Education4
Semiconductor/Telecommunications
Gaming/AI/Semiconductors1
R&D/Mfg
Mfg7
Semiconductor1
Gaming/AI/Semiconductors2
Mfg8
Gaming/AI/Semiconductors3
Datacenter12
Education5
Government1
Government2
Semiconductor2
Semiconductor/R&D/Mfg
Mfg9
Telecommunications1
Datacenter13
Education6
Datacenter14
Education7
Education8
Semiconductor3
Datacenter15
Bio Tech 1
Semiconductor/Telecommunications
Semiconductor/R&D/Mfg

East Loop 15MW
Datacenter16
Datacenter17
Gaming/AI/Semiconductors4

Northeast Loop 28MW
Security1
Property Management3
Property Management4
Entertainment1
NFL1
Property Management5
Entertainment2
Hotel1
Datacenter18
Medical1
Mfg10
Datacenter19
Datacenter20
Datacenter21
Datacenter22
Cyber Security 1
Hotel2
Property Management6
Mfg11
Datacenter/software/cloud computing
NFL2
NFL3
NFL4
Education9
Education10
Conventions 1
Education11
Semiconductor4
Datacenter23
Education12
Real Estate1
Network hardware1
Semiconductor5
Computer hardware/software 1

Northwest Loop 112MW
Medical2
Real Estate2
Real Estate3
Real Estate4
Datacenter24
Datacenter25
R&D2
Real Estate5
Real Estate6
Healthcare equipment
Education13
Semiconductor/R&D
Datacenter26
Property Management7
Computer hardware/software 2
Real Estate7
Datacenter27
Software1
Computer hardware/software 3
Cyber Security 2
Conventions 2
Hotel3
Medical3
Cyber Security 3
Education14
Datacenter28
R&D3
Semiconductor6
Storage1
Entertainment3
Property Management8
Medical4
Telecommunications2
NFL5
Datacenter29
Datacenter30
Datacenter31
Datacenter32
Telecommunications3
Datacenter33
Gaming/AI/Semiconductors5
Datacenter34

South Loop 65MW
Government3
Education15
Education16
Education17
Real Estate8
Design1
Security 2
Education18
Education19
Mfg12
Datacenter35
Education20
Education21
Education22
Education23
Education24
Education25
Education26
Healthcare1
Telecommunications4
Education27
Education28
Datacenter36
Datacenter37
Medical device
Education29
Education30
Healthcare2
Healthcare3
Healthcare4
Healthcare5

The:\MS\100-01 Laurelwood Substation\2000-0-0-0-1.dwg, 5/11/2018 8:27 PM By: Robbie Giffin, Proj. code: 111, P44, Size: AWD, All based D (24,000 x 22,000 inches)

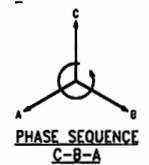
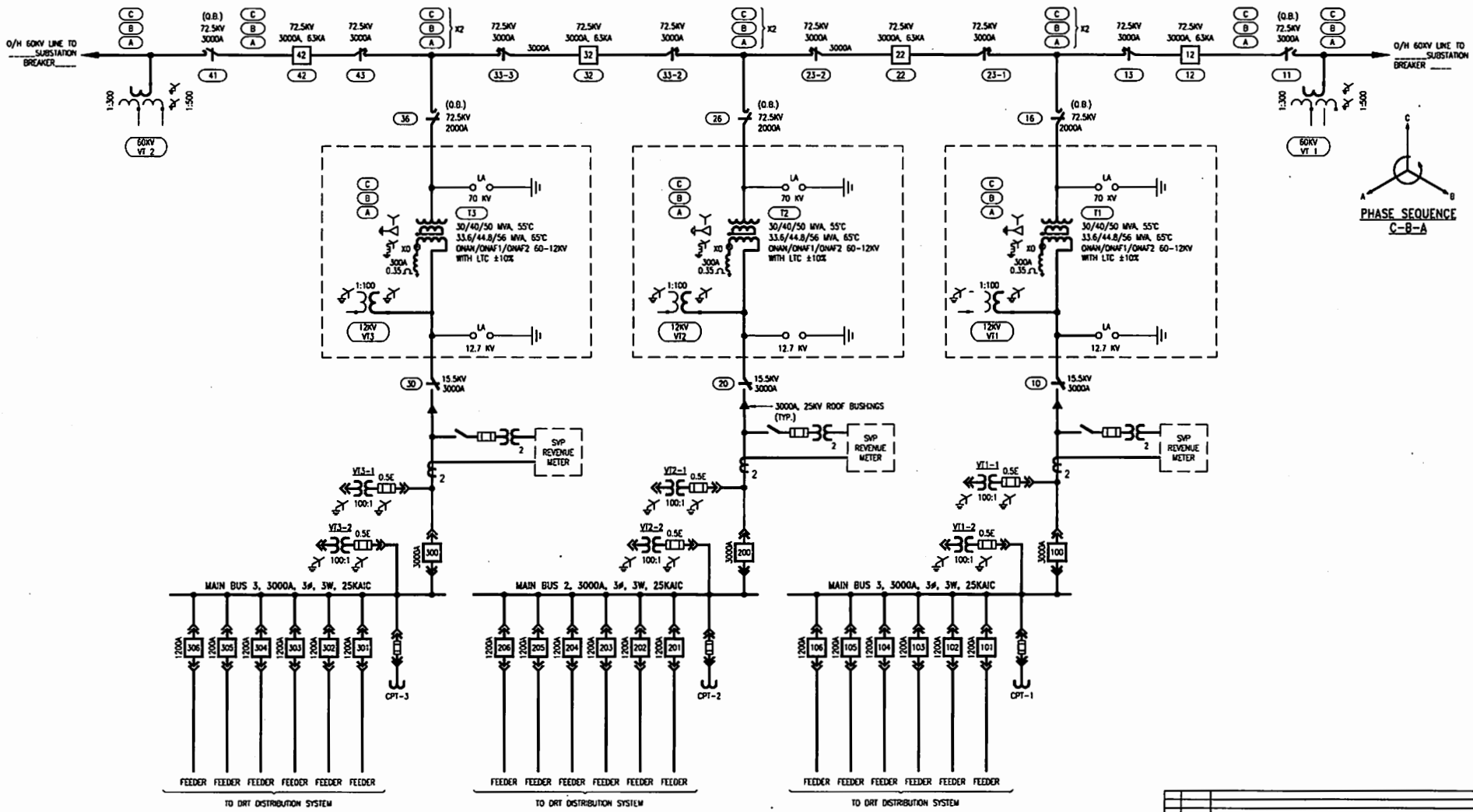

PRELIMINARY
05-07-2018

engineers, Inc.
 3300 south West, Suite 111
 Tempe, Arizona, 85281
 PHONE: (480) 844-8425
 FAX: (480) 844-8425
 PROJECT NO. 10818-01

REVISION		DESCRIPTION	

DESIGNED BY	LAURELWOOD SUBSTATION	DRAWN BY ENG	DATE/REV/APP
APPROVED BY	SINGLE-LINE DIAGRAM	SCALE: NS	SHP #/REV
			SH 1 OF 1

CITY OF SANTA CLARA
 COUNTY SAFETY POWER
 3000-E-0-X-1 A

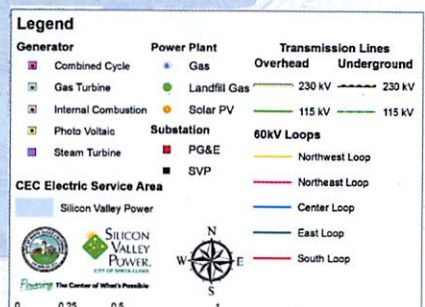
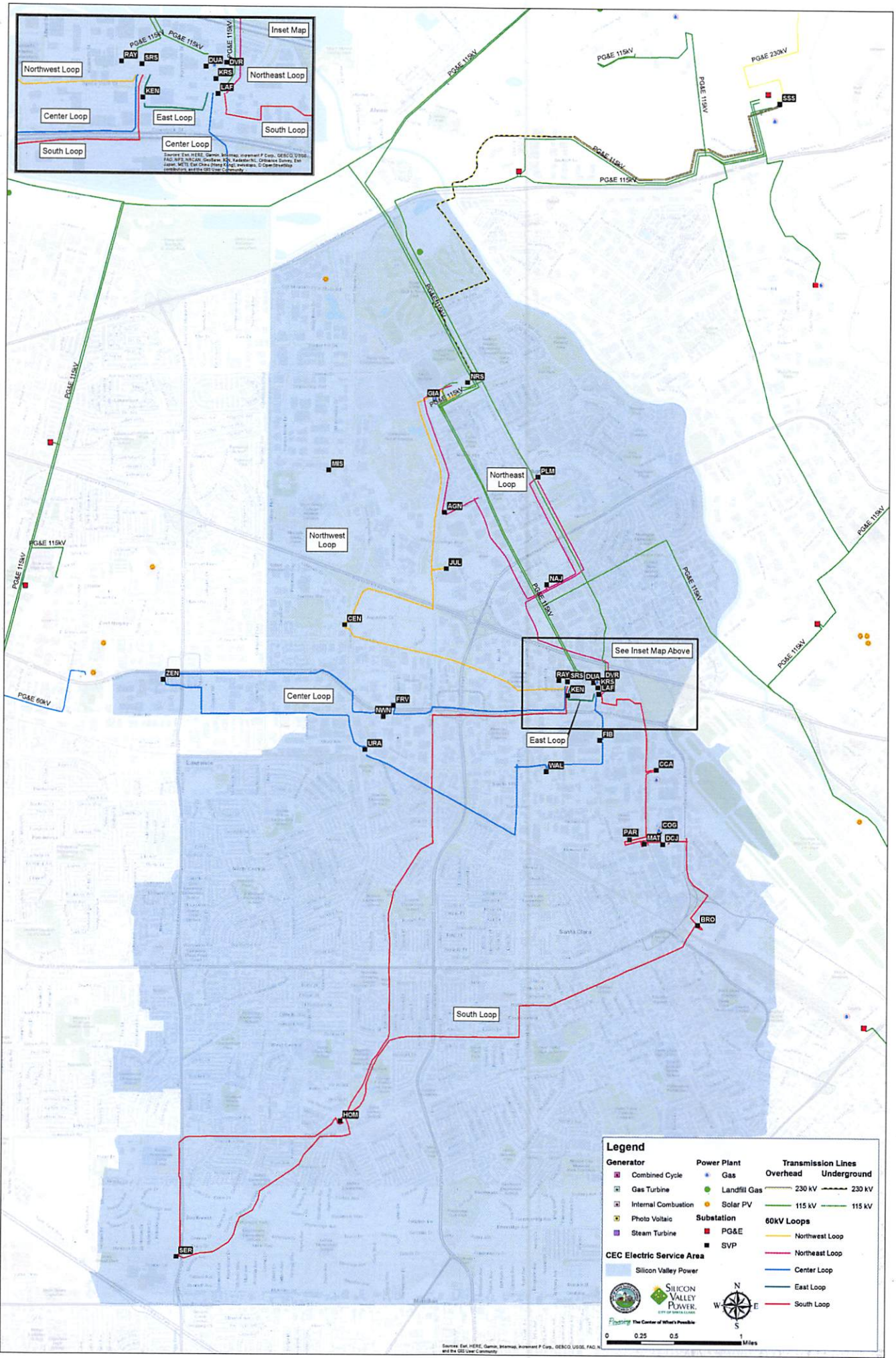
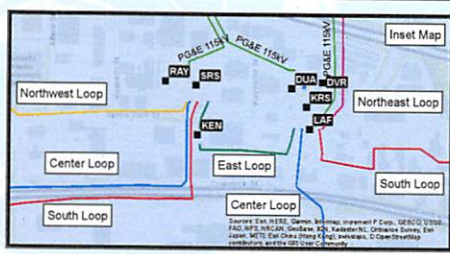

Source: Esri, HERE, Garmin, Microsoft, Intermap, P Corp., GEBCO, USGS, FAO, ... and the CEC User Community.

SVP Transmission Overview

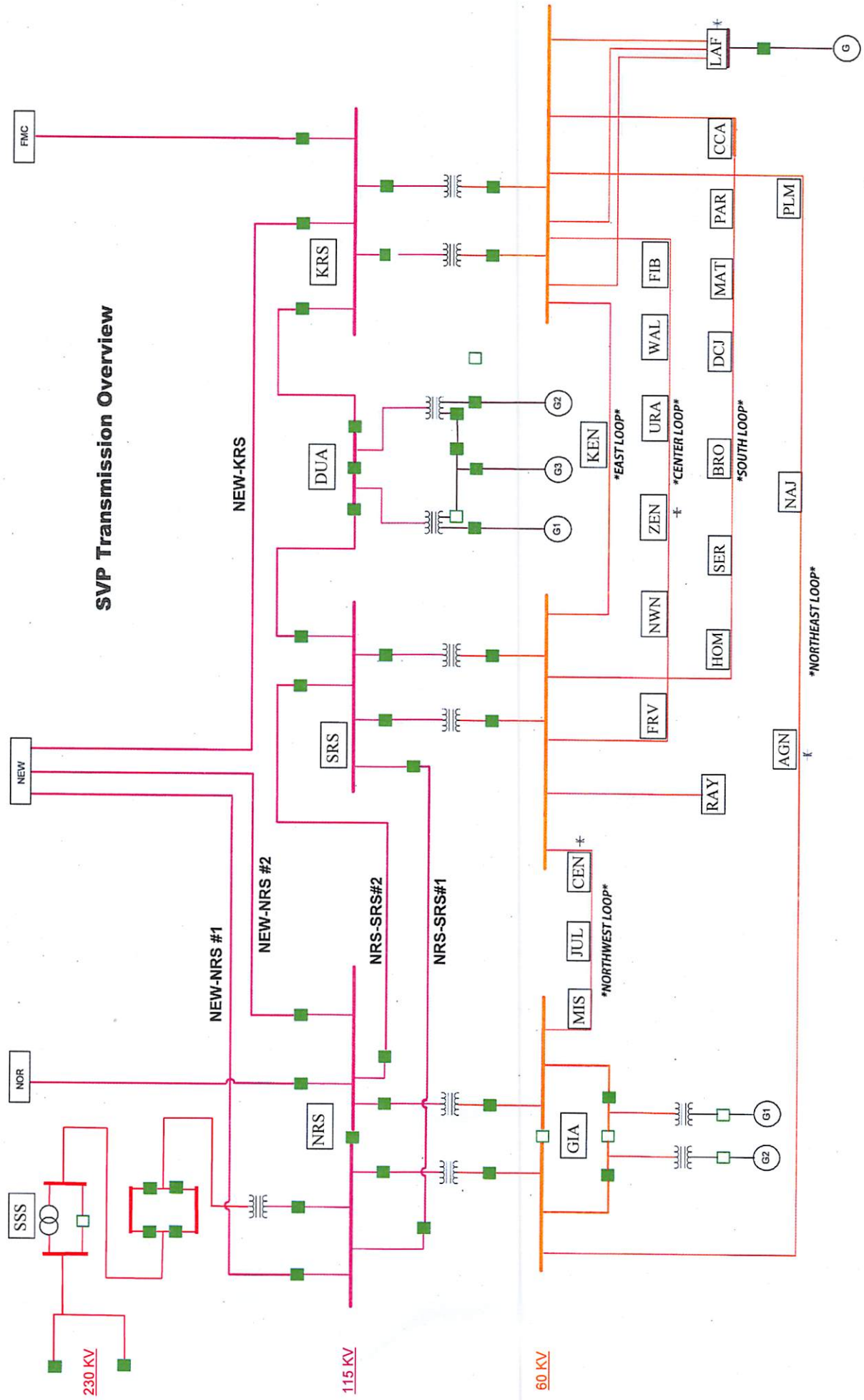

From: Kevin Kolnowski <KKolnowski@SantaClaraCA.gov>
Sent: Thursday, August 08, 2019 2:23 PM
To: Hesters, Mark@Energy <Mark.Hesters@energy.ca.gov>
Subject: FW: Follow up CEC questions

CAUTION: This email originated from outside of the organization. Do not click links or open attachments unless you recognize the sender and know the content is safe.

Mark, outlined below are the responses to your Monday, August 5th questions.

Please let us know if you have additional questions.

Thank you,

Kevin Kolnowski

Electric Utility Chief Operating Officer

From: Hesters, Mark@Energy [mailto:Mark.Hesters@energy.ca.gov]
Sent: Monday, August 05, 2019 1:09 PM
To: Kevin Kolnowski <KKolnowski@SantaClaraCA.gov>
Subject: Follow up CEC questions

Yes, we can talk to SVP before we file this or something else that SVP and their legal counsel approves of to the docket. I also have some questions that we can pose to them or send the questions to them before hand. Also, we should see if anyone else some follow up questions.

1. The Aug 2 response talks about the May 28/29, 2016 outage and the 28 customers that lost power. The table of outages in their response seems to list outages that affected 60kV customers, and these customers appear to be data centers customers and other, non-data center customers. Does SVP know how many of the 28 customers referred to on the May 28, 2016 entry were data centers? **Two Data Centers were affected.**
2. The Aug 2 response talks about a Dec 2, 2016 outage and the 257 customers that lost power. The table of outages in their response seems to list outage that affected 60kV customers, and these customers appear to be data centers customers and other, non-data center customers. Does SVP know how many of the 257 referred to on the Dec 2, 2016 entry were data centers? **Four Data Centers were affected.**
3. The Aug 2 response talks about a Dec 2, 2016 outage and the 257 customers that lost power. Can we get more information about this outage? Was it also an N-1-1 cascade like the series of faults that caused the May 28/29, 2016 outage? Why did we not hear about this outage earlier - was it different that the May 2016 outage (eg, internal faults versus an external fault like a balloon or squirrel)? **This outage was caused during maintenance work with the Relay Technician. During the testing, the relay was required to be reset prior to returning to service. Since the relay was not reset, when put back into service the device tripped. The Standard Operating Procedure was revised to include the step of resetting the relay prior to placing back into service. This was not a N-1-1 cascading type outage. The outage lasted 12 minutes.**

4. The Aug 2 response has a table of 60kV outages. Just to confirm, only the Dec 2 and May 28, 2016 outages affected data centers. So, for example, none of the 2927 customers affected by Mar 31, 2015 outage were data centers - is that correct? Correct, no data centers were effected during March 31, 2015 outage.
5. Also, it sounds like some data center customers are connected to 12kV feeds, but these feed are connected to the dual feed 60kV loops that are highly reliable. Is this correct, and how many customers might be on a 12kV line that comes off a 60kV loop? And how is reliability maintained on the 12kV line - looping, breakers and redundant equipment - like the 60kV loops?
Yes, this is correct. The electric services that supply power to our 12kV data center customers are from our general 60kV distribution substations, which is inherently connected to our 60kV looped system. The number of customers that are off a 12kV feeder (line) is limited to SVP's operational loading philosophy, which is 4.5MVA or 50% of the maximum 9MVA. Said in another way, we can have as few as one customer or as many as one-hundred on a feeder, as long as the entire load is less than 4.5MVA. To address reliability, by operating our 12kV feeders at half-loaded, SVP has operational flexibility to completely transfer loads to other 12kV feeders in the event of an outage. SVP may make an operational determination to limit a feeder to one data center customer, but at this time is not contractually obligated to provide as such.
6. The Aug 2 response has a 4.d. response regarding how the Vantage MECP1 data center responded to the the May 28/29, 2016 SVP outage that said "[t]he description of the Vantage event is reasonable, however cannot be directly applied to the Laurelwood Data Center. The Vantage event had a unique combination of contributing factors for which the resulting outcome cannot be reasonably assumed to be the expected outcome for line faults on the SVP 60kV network." Do you have more information on what were the "contributing factors", and why should we not assume that other data centers would have similar "expected outcomes"? As discussed in the 8/2/19 document, had the DC voltage supply cable not had an issue, a similar event would have been contained. Our anticipation, an outage in the future the protection system would operate as expected.
7. Regarding the Aug 2 response to PG&E's PSPS plans, could SVP curtailments ever allow a data center to operate under emergency conditions? To date this has not happened, the decision to operate during this situation would be by the data center. Our understanding is during emergency situation, individuals can operate their emergency generators.

Are SVP curtailments to PSPS conditions voluntary or emergency conditions? We understand that diesel emergency gensets cannot operate for economic reasons, only in response to an unplanned emergency or upset on their supply grid. We will be instructed to reduce load to respond to emergency conditions somewhere within the CAISO controlled grid, we have to follow what the CAISO directs us to do. The CAISO instructions are not voluntary. We would request customers to reduce load to satisfy the emergency condition and if that is not sufficient we will begin shutdown of our customers to meet the emergency situation. We would be operating at the direction of the CAISO.
8. Are there any plans that part of the PSPS program might include payments to some loads to curtail or shed? SVP does not have a plan to pay a data center to shed or curtail load.

9. Would the 6 interconnection points with the PG&E system allow SVP/PG&E to wheel bulk deliveries around potential shutdowns on the PG&E system? In other words, is the current understanding of the PSPS program that most shutdown will be in specific areas and not across the greater PG&E system, and that would allow PG&E to work around an area that would be fully shutdown? The understanding is if the conditions are such where transmission has to be curtailed, the CAISO will require load reductions of the CAISO controlled grid, similar to the energy crisis from the early 2000's. SVP will request voluntary reductions to meet the CAISO demand or will make switching changes which to remove blocks of customers load. It will depend how much reductions the CAISO will be instructing us to reduce, voluntary load shedding and customer shutoff.

Matt

Mark Hesters
California Energy Commission
(916)654-5049