

DOCKETED

Docket Number:	19-BSTD-06
Project Title:	Local Ordinances Exceeding the 2019 Energy Code
TN #:	229980-10
Document Title:	Santa Monica 2019 - SM Pool Heating-Final
Description:	N/A
Filer:	Gabriel Taylor
Organization:	California Energy Commission
Submitter Role:	Commission Staff
Submission Date:	10/7/2019 2:22:37 PM
Docketed Date:	10/7/2019

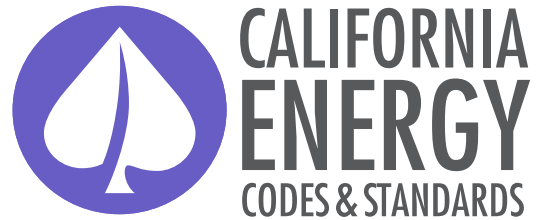

A STATEWIDE UTILITY PROGRAM

Title 24, Part 6
Local Energy Efficiency Ordinances

**Cost Effectiveness Study:
All Electric Heat Pump Pool Heating -
Non-Preempted**

Prepared for:

Jeremy Reefe
Codes and Standards Program
San Diego Gas and Electric

Prepared by:

Energy Solutions
Misti Bruceri & Associates, LLC

Last Modified: August 18, 2019



LEGAL NOTICE

This report was prepared by San Diego Gas & Electric Company and funded by the California utility customers under the auspices of the California Public Utilities Commission.

Copyright 2019, San Diego Gas & Electric Company. All rights reserved, except that this document may be used, copied, and distributed without modification.

Neither SDG&E nor any of its employees makes any warranty, express or implied; or assumes any legal liability or responsibility for the accuracy, completeness or usefulness of any data, information, method, product, policy or process disclosed in this document; or represents that its use will not infringe any privately-owned rights including, but not limited to, patents, trademarks or copyrights.

Table of Contents

1	Introduction.....	2
2	Methodology and Assumptions.....	2
2.1	Swimming Pool Prototype and Assumptions.....	3
2.1.1	Existing Pool Heating Regulations.....	4
2.1.2	Federal Preemption	4
2.2	Technology and Measure Descriptions.....	4
2.2.1	Gas Pool Heater Technology Summary.....	4
2.2.2	HPPH Technology Summary.....	4
2.2.3	Pool Heater Sizing Methodology and Industry Trends	6
2.2.4	Base case Description	7
2.2.5	Measure case Description.....	7
2.2.6	Equipment Cost.....	8
2.3	Cost Effectiveness	9
3	Results.....	11
3.1	Key Assumptions and Analysis Sensitivities.....	11
3.2	Conclusions & Summary	13
4	References	13
	Appendix A – Cost Effectiveness Details.....	15

List of Tables

Table 1:	Average high and low temperatures in Santa Monica, CA	3
Table 2:	Base case/ Measure Descriptions & Cost Assumptions.....	9
Table 3:	IOU Utility Tariffs and Rate Estimates.....	10
Table 4:	Cost-Effectiveness Results.....	11
Table 5:	Cost-effectiveness Details.....	15
Table 6:	Customer Utility Life-cycle Costs.....	15

List of Figures

Figure 1:	Common In-ground Pool Equipment and Plumbing Schematic	3
Figure 2:	Brookhaven National Labs COP Test Results, Rheem Model 8320ti HPPH	5
Figure 3:	Heat Pump Pool Heater Performance	6
Figure 4:	Equipment Cost Data	8

1 Introduction

The California Building Energy Efficiency Standards Title 24, Part 6 (Title 24) (California Energy Commission, 2018) is maintained and updated every three years by two state agencies, the California Energy Commission (CEC) and the Building Standards Commission (BSC). In addition to enforcing the code, local jurisdictions have the authority to adopt local energy efficiency ordinances, or reach codes, that exceed the minimum standards defined by Title 24 (as established by Public Resources Code Section 25402.1(h)2 and Section 10-106 of the Building Energy Efficiency Standards). Local jurisdictions must demonstrate that the requirements of the proposed ordinance are cost-effective and do not result in buildings consuming more energy than is permitted by Title 24. In addition, the jurisdiction must obtain approval from the CEC and file the ordinance with the BSC for the ordinance to be legally enforceable.

This report documents the assumptions and cost-effectiveness analysis comparing an all-electric heat pump pool heater (HPPH) to a gas pool heater when a pool has pool heating supply. Currently Title 24 Part 6 bans electric resistance pool heating unless 60% of annual pool heating demand is met by site-solar or recovered energy. Additionally, if a pool is heated by a heat pump or gas pool heater, a pool cover is required (California Energy Commission, 2018).

The 2009 Residential Appliance Saturation Study (RASS) study (KEMA, 2010) shows that 57% of pools in SCE territory have some form of pool heating (natural gas, solar thermal, electricity or propane) and the vast majority (80%) use natural gas. Furthermore, in Santa Monica's climate zone — Energy Commission Climate Zone 6 — homes with a pool and/or spa use 277 therms of natural gas per year. While natural gas pool heaters have historically dominated the residential pool heating market in California, based on conversations with manufacturers, HPPHs are much more common in other major pool markets such as Florida. In Florida, a combination of mild temperatures and low electricity prices have historically made HPPHs a cost-effective choice for many pool owners.

An important note to highlight is that pool heating is not required in new pool construction. In fact, as noted above, 43% of pool owners in SCE territory do not have a pool heater. In many climates supplemental heating systems are unnecessary and in others a solar thermal pool cover provides enough heating. Pool heating systems are often added to extend the summer swim season into the spring and fall months. Renewable solar thermal energy systems are also relatively common, however it is not always practical due to roof-space, shading, or its inability to provide heating on-demand, and therefore not a suitable substitute for all pool heating systems in all residences.

In summary, the proposed code change in this report requires that heated pools use site-solar or recovered thermal energy, and/or a HPPH. Therefore, the analysis in this report focuses exclusively on the cost-effectiveness of a HPPH compared to the base case of a gas pool heater.

2 Methodology and Assumptions

This analysis uses a site energy savings methodology with customer-based lifecycle cost (LCC) analysis valuing energy based upon estimated site energy usage and utility rate schedules. This methodology requires estimating and quantifying the energy savings associated with energy efficiency measures, as well as quantifying the costs associated with the measures from the customer's perspective.



2.1 Swimming Pool Prototype and Assumptions.

In proposing the first-in-the-nation swimming pool building code standards (which the CEC ultimately adopted) in 2008, the IOU Codes and Standards Team used a 20,000 gallon in-ground swimming pool to evaluate the cost-effectiveness of various measures for new pool construction (PG&E and Sempra Energy, 2007). Similarly, this analysis assumes a 20,000 gallon in-ground swimming pool in evaluating the cost-effectiveness of pool heating equipment.

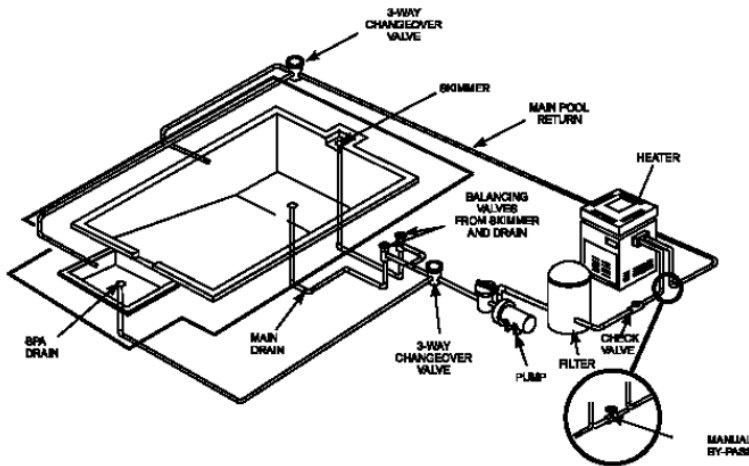

Figure 1: Common In-ground Pool Equipment and Plumbing Schematic
 Source: (Brookhaven National Laboratory, 2009)

This analysis makes two other key assumptions about the average pool:

- **Pool Temperature:** The desired temperature for the heated pool is 80°F.
- **Swim Season:** Pool heating is generally used to extend the summer swim season. This analysis assumes heating occurs on weekends March through October, as shown below in Table 1. Note that because the model was calibrated to match RASS annual gas consumption of 277 therms (KEMA, 2010), the actual hours of run-time are less important, but useful in determining temperature conditions for heat pump performance.

Table 1: Average high and low temperatures in Santa Monica, CA

	Assumed Pool Heating Season											
Month	Jan	Feb	Mar	Apr	May	Jun	Jul	Aug	Sep	Oct	Nov	Dec
Average high °F	64	63	62	63	64	66	69	70	71	70	67	65
Average low °F	50	51	52	54	56	59	62	63	63	59	54	51
Average °F	57	57	57	58.5	60	62.5	65.5	66.5	67	64.5	60.5	58

Source: (U.S. Climate Data, 2019)



2.1.1 Existing Pool Heating Regulations

Pool heaters are currently regulated through a variety of state and federal energy efficiency standards and building codes. This measure will not conflict with any of these standards, but they are briefly summarized below for context.

- **Title 24 Part 6:** California has had building code standards in effect since 2010. The code bans electric resistance pool heating unless 60% of annual pool heating demand is met by site-solar or recovered energy. Additionally, if a pool is heated by a heat pump or gas pool heater, a pool cover is required (California Energy Commission, 2018).
- **Title 20:** California has had an appliance standard for HPPHs since 2003. The current standard requires an average coefficient of performance (COP) of 3.5 between the COP of the 80°F test point and 50 °F test point (California Energy Commission, 2019).
- **Federal:** The Department of Energy (DOE) has minimum energy efficiency standards for gas-fired pool heaters. The current standard requires pool heaters have an 82% thermal efficiency (Department of Energy, 2010).

2.1.2 Federal Preemption

As mentioned above, DOE sets minimum efficiency standards for equipment and appliances that are federally regulated under the National Appliance Energy Conservation Act, including heating, cooling, and water heating equipment. Since state and local governments are prohibited from adopting higher minimum efficiencies than the federal standards require, the focus of this study is to identify and evaluate cost-effective measures that do not include high efficiency federally regulated equipment. This measure proposes requiring a CA Title 20 regulating HPPH, not requiring a higher efficiency federally regulated gas pool heater, therefore preemption is not an issue. Pool heaters (gas and HPPH) are now both rated with a DOE test procedure (Code of Federal Regulations, 2019).

2.2 Technology and Measure Descriptions

The technology analyzed in this report is mature; there is enough data on product performance due to decades of efficiency standards. However, data on the application and sizing pool heating is limited. This study selected pool heaters and capacities based on experience, conversations with manufacturers and expert pool professionals.

2.2.1 Gas Pool Heater Technology Summary

Gas pool heaters utilize a combustion chamber and heat exchanger to warm the water supplied from the filtration pump, before returning to the pool. It should be noted that gas pool heaters are rated and advertised based on input capacity. To get to output capacity, input capacity is multiplied by the thermal efficiency, or roughly 82% based on DOE minimum standards.

2.2.2 HPPH Technology Summary

A HPPH uses a heat pump to move and transfer heat from the surrounding air to the pool water through a heat exchanger. HPPHs are rated on output capacity and are typically advertised at their high air temperature (80°F), high humidity (80% relative humidity), and 80°F water temperature test point (commonly denoted as 80/80/80). This is one of the test points required by California's Title 20 appliance standards (California Energy Commission, 2019). This is unlike gas heaters typically advertised



based on input capacity. HPPHs also are rated at other conditions such as 80/63/80, 50/63/80 and 80/63/104 (spa conditions) as required by the CEC and an Air-Conditioning and Refrigeration Institute equipment databases (AHRI, 2019).^[66] At each output capacity for these ratings, a COP value is produced which is a function of useful heat compared to work required, or in other words a measurement of how efficient the heat pump is at the given conditions.

2.2.2.1 Determining COP for Modeling

COP data published at standard conditions by CEC is useful, however outside conditions are always changing, so determining the exact COP at any given temperature is challenging. There is not a linear relationship and unlike other heat pump applications, publicly available modeling software does not exist for HPPHs. However, a 2009 study at Brookhaven National Labs conducted testing of pool heating equipment and for at least one particular model found COPs to be relatively stable from roughly 57°F and up, but COP declined below 57°F as would be expected (Brookhaven National Laboratory, 2009).

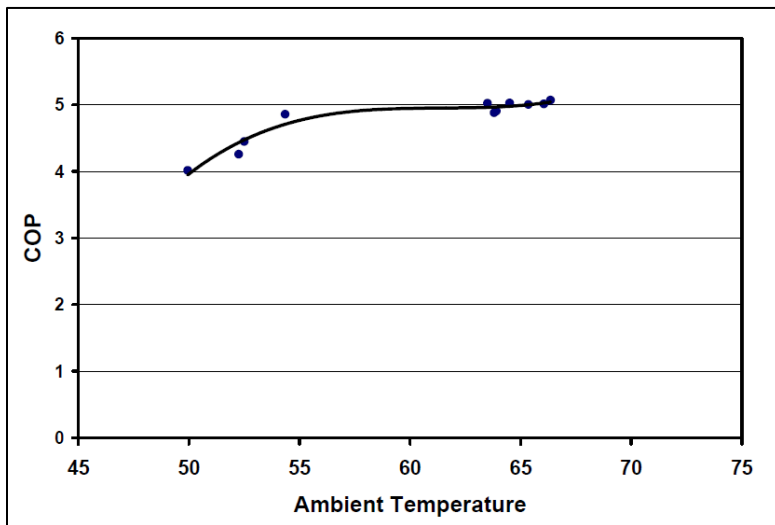

Figure 2: Brookhaven National Labs COP Test Results, Rheem Model 8320ti HPPH
Source: (Brookhaven National Laboratory, 2009)

To determine what COP to use in modeling energy consumption for HPPHs for this analysis, the CEC database was leveraged to determine average performance. Figure 3 below plots the 325 models of HPPHs in the CEC database of August 2019. As mentioned previously, CEC has had an appliance standard for HPPHs since 2003 requiring the average of the standard (warm) and low temperature condition COP values to be greater than 3.5. Currently the database shows the lowest average COP at the warm and low temperature conditions to be 4.0, significantly higher than the standard. Furthermore, taking a simple average of the “average COPs” yields a COP of 4.8 (MAEDbS, 2019). As Figure 3 below shows, in warm conditions, COPs mostly range between 5 and 6.5. Therefore, given the HPPH will likely operate mostly during the warmer swim season using TOU rates, mostly during warmer day-time off-peak hours, a COP of 4.8 was selected as a reasonable middle ground between a code minimum and likely real-world performance.



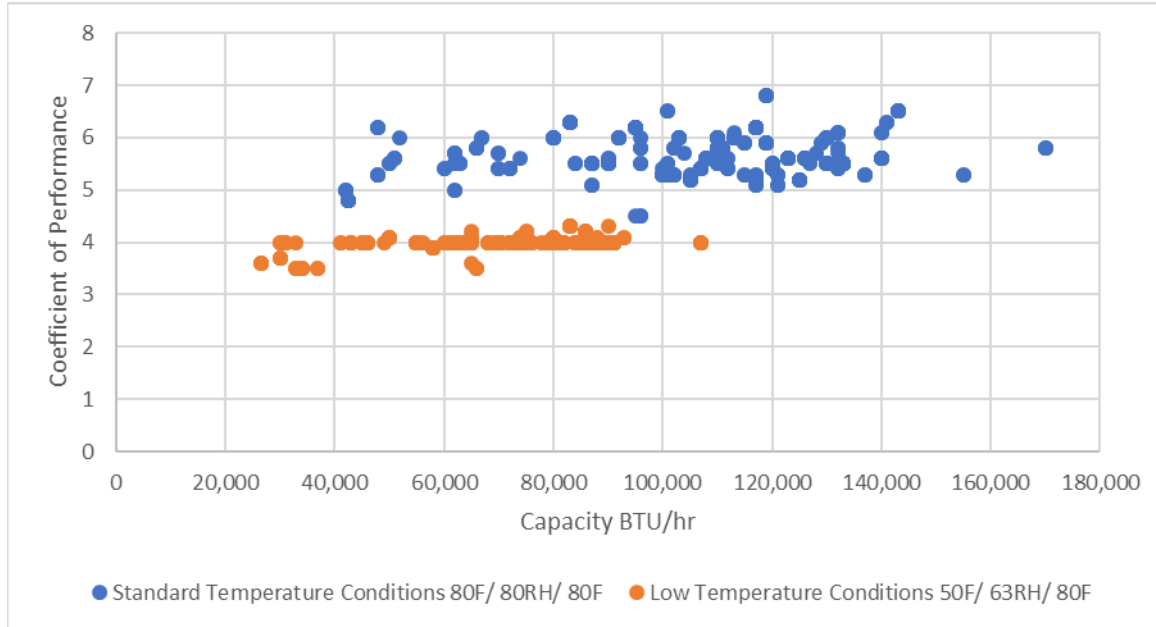

Figure 3: Heat Pump Pool Heater Performance

Source: (MAEDbS, 2019)

2.2.3 Pool Heater Sizing Methodology and Industry Trends

This analysis presents a range of cost-effectiveness for the measure due to two different likely base cases. In practice, there is a range of pool heater sizing recommendations in the market, especially for gas pool heaters. In many cases gas pool heater sizing has long been influenced by “bigger is better.” Pool heaters are often sized for a worst-case winter-heating scenario and the ability to raise the temperature of the pool in a certain period on a cold day. There are advantages to large capacity gas pool heaters as they can heat a pool or spa more quickly than a smaller capacity pool heater, for a relatively low incremental cost. However, this often leads to significantly oversized equipment for in residential applications, especially in mild climates like southern California.

In the CEC database, the average residential gas pool heater capacity (where residential is defined as $400 \text{ kBTU}_{\text{input}}$) is $270 \text{ kBTU}_{\text{input}}$ (or $\sim 226 \text{ kBTU}_{\text{output}}$ assuming a DOE minimum efficiency of 82%), whereas the average residential pool heater heat pump is $107 \text{ kBTU}_{\text{output}}$. Heat pump pool heaters have a much narrower band of capacities in the market and in the residential segment generally have a maximum capacity of $140 \text{ kBTU}_{\text{output}}$ (MAEDbS, 2019).

Pool heaters of a $140 \text{ kBTU}_{\text{output}}$ capacity (gas or HPPH) in a normal climate would operate the same and could meet make-up heat and start-up heating demands for the average pool in Santa Monica’s climate. However, it will do so slower than a $400 \text{ kBTU}_{\text{input}}$ gas heater.

In general, while not intuitive, most pool heater sizing recommendations yield higher capacity gas heaters compared to heat pumps. For example, according to the online retailer poolcenter.com, a $300 \text{ kBTU}_{\text{input}}$ (or $246 \text{ kBTU}_{\text{output}}$) sized pool heater would be recommended for a 20,000 gallon pool. However, for HPPHs, the same poolcenter.com website states “For pool heat pump sizing, as a general rule, plan on 50,000 BTU of pool heat pump for every 10,000 gallons of pool water” (Pool Center, 2019). Therefore, it is recommended to have roughly a $100 \text{ kBTU}_{\text{output}}$ pool heater for a 20,000 gallon pool. This is less than half of the capacity recommended for a gas pool heater of $246 \text{ kBTU}_{\text{output}}$.

As another example of this technology disconnect, for Raypack (one of the largest pool heater manufacturers), the largest in-ground heat pump manufactured is 140 kBTU_{output} and the smallest in-ground gas pool heater is 200 kBTU_{input} or 164 kBTU_{output} (Raypack Inc., 2019). There is no overlap in capacities for products marketed to the same sized pools. Since the capacity of a gas heater has significant bearing on the first cost, and for reasons explained above, the measure is evaluated against two base cases as described below.

2.2.4 Base case Description

Large Sized (266 kBTU_{input}/ 218 kBTU_{output}) Gas Pool Heater: This base case is designed to reflect the capacity of a “large” gas pool heater. This pool heater size reflects the average gas pool heater size in the CEC database of 275 kBTU_{input}. Heaters of this capacity are able to heat a pool faster than a right-sized pool heater and are generally recommended when a spa is attached to allow for quick heat-ups of the spa on demand. Therefore, the representative unit selected is a 266 kBTU_{input} pool heater (a commonly available size) with a DOE minimum thermal efficiency of 82%, yielding an output capacity of 218 kBTU_{output}. The equipment cost of a pool heater of this capacity is estimated to be \$1,832 with an equipment lifetime of 10 years. A pool heater of this size will be able to heat a 20,000-gallon pool from 57°F (Santa Monica’s average air temperature in March) to 80°F in roughly 18 hours, representative of a spring “pool opening” heat-up.

Right Sized (135 kBTU_{input}/ 111 kBTU_{output}) Gas Pool Heater: This base case is designed to reflect the capacity of a smaller, but “right-sized” gas pool heater. This pool heater will heat slightly slower from cold temperatures but will be able to meet heat loss recovery throughout the swim season. Pool heaters of this size may not be recommended when a spa is attached due to increased time for spa heat-up, but there is plenty of capacity to do so should pool owners allow the time. The representative unit is a standard-sized 135 kBTU_{input} pool heater (a commonly available size) with a DOE minimum thermal efficiency of 82%, yielding an output capacity of 111 kBTU_{output}. The equipment cost of a pool heater of this capacity is estimated to be \$1,426 with an equipment lifetime of 10 years. A pool heater of this size will be able to heat a 20,000-gallon pool from 57°F to 80°F in roughly 35 hours.

2.2.5 Measure case Description

This following is a description of the efficiency measures applied in this analysis.

Standard Capacity (110 kBTU_{output}) Heat Pump Pool Heater: This measure case is designed to reflect the capacity of a standard-sized HPPH. This pool heater size roughly reflects the average HPPH capacity in the CEC database of 107 kBTU_{output} at outside air conditions of 80°F. In mild conditions, generally above 60 degrees, this pool heater will be able to perform in a similar capacity to the right-sized 111 kBTU pool heater referenced above. At lower temperatures down to 50°F, it will work sufficiently, just at a lower COP. Again, pool heaters of this size are sometimes not recommended when a spa is attached due to increased time for spa heat-up, though it is possible with additional time. The representative unit is a standard-sized 110 kBTU_{output} pool heater (a commonly available size) with a COP of 4.8, given the temperate conditions in Santa Monica during the swimming pool heating season (the reasoning for this COP value is explained above in Section 2.2.2.1). The equipment cost of a pool heater of this capacity is estimated to be \$2,895 with an equipment lifetime of 10 years. Similar to the right-sized gas pool heater base case, a pool heater of this size will be able to heat a 20,000-gallon pool from 57°F to 80°F in roughly 35 hours.



2.2.6 Equipment Cost

To determine equipment costs, data was gathered from the online pool equipment retailer InyoPools for three common pool heater brands that make both inground pool gas pool heaters and HPPHs: Raypack, Pentair and Hayward (InyoPools.com, 2019). A linear regression model was then created to model the equipment price of the representative units.

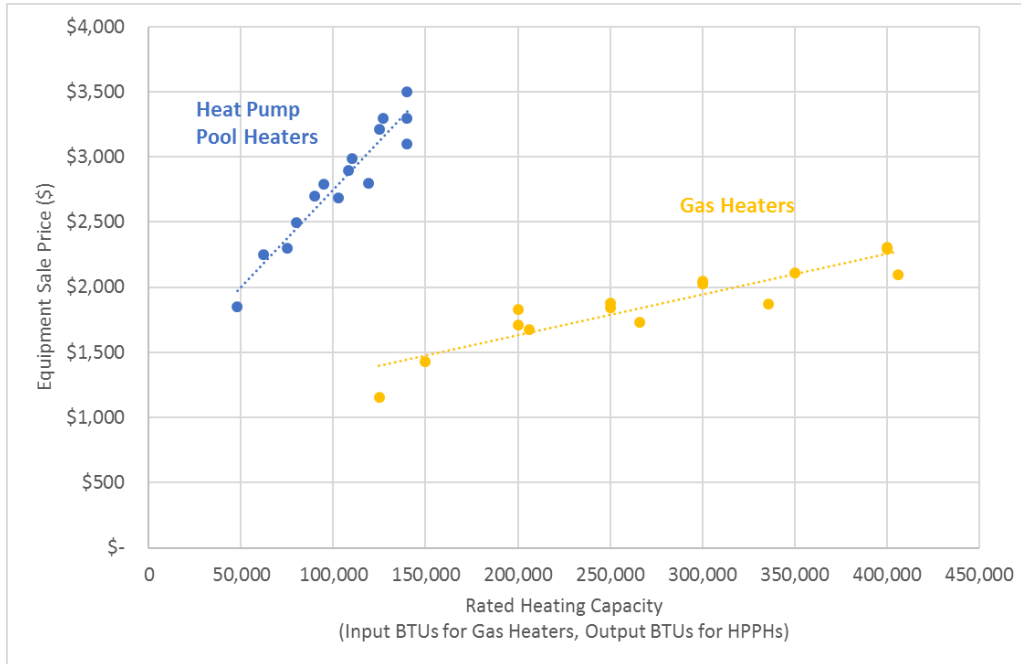

Figure 4: Equipment Cost Data

Source: (InyoPools.com, 2019)

Using the data and linear regression above in Figure 4, costs for the representative equipment is displayed below in Table 2. Additional gas and electrical costs are displayed as well.



Table 2: Base case/ Measure Descriptions & Cost Assumptions

Measure	Performance Level	Cost	Source & Notes
Large Sized (218 kBTU _{output}) Gas Pool Heater	82% thermal efficiency	\$1,832	Average cost of 266,000 BTU input gas pool heater based on data collected and created linear regression model: http://www.inyopools.com/category_heaters.aspx
Right- Sized (111 kBTU _{output}) Gas Pool Heater	82% thermal efficiency	\$1,426	Average cost of 135,000 BTU input gas pool heater based on data collected and analyzed linear regression model: http://www.inyopools.com/category_heaters.aspx
Standard Capacity (111 kBTU _{output}) Heat Pump Pool Heater	COP of 4.8	\$2,895	Average cost of 110,000 BTU output gas pool heater based on data collected and analyzed linear regression model: http://www.inyopools.com/category_heaters.aspx
Incremental Gas Line Extension Cost for Gas Heaters	N/A	\$200	2019 Cost-effectiveness Study: Low-Rise Residential New Construction Study: https://localenergycodes.com/download/800/file_path/fieldList/2019%20Res%20NC%20Reach%20Codes
Incremental Electrical Hardware for Heat Pump Pool Heater	N/A	\$5	Incremental cost for a 220v 40amp circuit breaker over a 120v 20amp circuit breaker. https://www.homedepot.com/p/Square-D-Homeline-40-Amp-2-Pole-Circuit-Breaker-HOM240CP/202353324

2.3 Cost Effectiveness

The current residential utility rates at the time of the analysis were used to calculate utility costs for all cases and determine cost effectiveness for the base and measure case. Annual utility costs were calculated using monthly electricity and gas consumption and applying the utility tariffs summarized in Table 3. The standard residential rate (TOU-D in SCE territory for electricity, & GR in SoCal Gas for gas) was applied to the base case and measure case. Pool heating was assumed to occur during off-peak hours aligning with the recommended operating times of pool pumping and general day-time hours during high pool usage. Electric rates represent a simple average of winter and summer off-peak rates and gas rates represent a simple of average of baseline and non-baseline rates. Projections of rate escalations reflect forecasted rate increases as documented by the *2019 Cost-effectiveness Study: Low-Rise Residential New Construction Appendix B: Utility Rate Tariffs* (CA IOUs, 2019).



Table 3: IOU Utility Tariffs and Rate Estimates

Electric / Gas Utility	Electricity Tariff (Time-of-use)	Natural Gas Tariff
SCE /SoCal Gas	TOU-D*	GR**
Year	\$/ kWh	\$/ therm
2020	\$ 0.19	\$ 1.30
2021	\$ 0.19	\$ 1.35
2022	\$ 0.20	\$ 1.40
2023	\$ 0.20	\$ 1.46
2024	\$ 0.21	\$ 1.52
2025	\$ 0.21	\$ 1.58
2026	\$ 0.21	\$ 1.60
2027	\$ 0.22	\$ 1.61
2028	\$ 0.22	\$ 1.63
2029	\$ 0.22	\$ 1.64
* Assumes a simple average of summer and winter off-peak rates		
** Assumes a simple average of baseline and non-baseline rates		

Source: (CA IOUs, 2019)

The benefit-to-cost ratio is a metric which represents the cost effectiveness of the measure over the 10-year estimated equipment lifetime, including discounting of future savings. All costs are assumed to occur in year zero and are not financed. A value of one indicates the savings over the life of the measure are equivalent to the incremental cost of that measure. A value greater than one represents a positive return on investment. The ratio is calculated as follows where the discount rate is 3%.

Equation 1

$$Lifecycle\ Benefit\ Cost\ Ratio = \frac{Net\ Present\ Value\ of\ lifecycle\ utility\ cost\ savings}{First\ incremental\ cost}$$

Simple payback is also calculated based on the first incremental cost and the average energy savings over the 10 years of the equipment life. Maintenance costs were not included because there are no known incremental maintenance costs expected for any of these measures. See Table 4 below for final results and Table 5 and Table 6 in Appendix A for more details.



Table 4: Cost-Effectiveness Results

Measure	Electrical Savings (kWh)	Gas Savings (therms)	% GHG Savings by 2029 ¹	Incremental Cost	Year 1 Utility Cost Savings	Simple Payback	Lifecycle B/C Ratio
HPPH replacing Right-sized Gas Pool Heater	(1,355)	277	83%	\$ 1,274	\$ 105	9.7	0.87
HPPH replacing Large-sized Gas Pool Heater	(1,355)	277	83%	\$ 868	\$ 105	6.6	1.27

¹Avoided GHG emissions from the adoption of this measure are calculated in accordance with California’s projected emissions factors as outlined in the 2017 update to the California Air Resources Board (CARB) scoping plan to meet the 2030 greenhouse gas targets (CARB 2017). By 2029, at the end of the design life, annual statewide emissions are projected to be 180 MtCO₂e/GWh for electricity and 5,556 MtCO₂e/MMtherm for natural gas.

3 Results

The cost-effective analysis presents mixed results, depending on the assumed base case heating scenario. According to Table 4, if the large sized gas pool heater is assumed to be the baseline, then the HPPH measure is cost-effective with a B/C ratio of 1.27. If a right-sized gas pool heater is assumed to be the baseline, then the HPPH is not cost-effective with a B/C ratio of 0.87. This report identified the size of the base case gas pool heater to be a key variable in cost-effectiveness, therefore results for both base cases were presented for consideration. However, there are several other factors this cost-effectiveness analysis is sensitive to which are described in greater detail below.

3.1 Key Assumptions and Analysis Sensitivities

- Rate changes:** This proposal is a fuel-switching measure therefore it is highly sensitive to tariff changes or rate increases and decreases for both gas and electricity. This measure would not be cost-effective for either base case if there were not significant rate increases planned in SCG’s territory in the next few years. The analysis also assumes that pool heating is performed during off-peak hours, meaning not 4pm-9pm. Because the pool filter pump is needed to pump water through the pool heater, it makes sense that the vast majority of pool and spa heating occur during off-peak hours. However, if hourly or daily pool heating data were made available showing pool heating occurs at any significant amount during on-peak hours, this could impact the cost-effectiveness.
- Gas Consumption Data Granularity:** The model was calibrated to the annual gas consumption of pool and spa heating in the RASS 2009 study of 277 therms (229 for pool heating and 48 for spa heating) (KEMA, 2010). Monthly estimates of gas consumption are not available in RASS or any other studies the report authors could identify. Monthly pool heater usage or energy consumption data would be especially helpful to align with monthly weather data to better estimate HPPH performance (COPs) and to better align with seasonal electric and gas rate changes.
- Gas infrastructure costs:** This analysis assumed an avoided cost of \$200 per gas appliance, the same value used in the *2019 Cost-effectiveness Study: Low-Rise Residential New Construction*



Study (CA IOUs, 2019). However, because pool heaters are located outside and sometimes further away from the house, this could underestimate the avoided cost of running a gas line extension to a backyard. Additionally, it should be noted that this analysis essentially assumes that gas service is already at the home and *does not* count gas main extensions, service lateral or a gas meter costs towards the cost of a gas pool heater. If a gas pool heater is the only gas appliance at a home, and these costs were added as incremental costs, this would make the HPPH cost-effective by a significant margin.

- **Pool heater sizing:** As has been described in this report, the analysis is highly sensitive to pool heater sizing assumptions. The pool heating industry has numerous “rules of thumb” about pool heater sizing. In a mild climate like Santa Monica’s, most pool heaters ranging from 100 kBtu to 400 kBtu will work, with the larger capacity units providing heating more quickly. Understanding consumer preferences and installed market data of pool heater capacity would help refine the base case scenarios and thus provide a more accurate estimate of the cost effectiveness of HPPHs.
- **COP of HPPHs:** Data and studies of the performance of HPPHs is very limited and manufacturers do not report or even generate COP as a function of temperature curves, so it can be challenging to model exact performance. This analysis interpolated as best as possible from the Brookhaven National Lab pool heater testing study and CEC appliance database to estimate COP values. Should better data become available, it would allow more precise modeling of COP as temperature conditions change throughout the year.
- **Labor installation costs:** The cost to install both gas heaters and HPPHs was assumed to be the same across both the base cases and the measure, though it is possible one might take more time to install than the other, but there is no data to support any differences. Interviews with pool contractors could help provide insight into these installation costs.
- **Market acceptance:** HPPHs are not a new technology for pool heating and have been deployed in other pool markets for many years. However, they have had only a very small market share in CA historically. As has been described, gas pool heaters have larger capacities and the ability to heat water more quickly than HPPHs. Based on internet reviews, this “fast-heating” capacity is most appreciated by pool owners whose pools have attached in-ground spas as they may not want to wait for a longer “heat up” with a HPPH. It should be noted that recently the market has responded to consumers wanting both the efficiency of a HPPH and the faster heating capacity of a gas pool heater with the manufacturer Pentair launching a hybrid HPPH and gas heater in 2018.¹ If having a “fast-heating” pool heater option was deemed necessary for pool owners with an attached spa it could alter this analysis and any code recommendations. For example, should a minimum attached spa heat-up time be required (e.g. no more than ~2 hours), the code *could* be written such that HPPHs be required for stand-alone pools, and gas or hybrid (gas & HPPH) heaters could be allowed for pools with attached spas. However, this is a policy judgement beyond the scope of this report. To assess this question of HPPH market acceptance further, interviews could be conducted with manufacturers and equipment installers in markets with a

¹ <https://www.pentair.com/en/products/pool-spa-equipment/pool-heaters/ultratemp-hybrid-heater.html>



high saturation of HPPHs to understand if their performance is a barrier for pool owners with attached spas.

3.2 Conclusions & Summary

This report evaluated the feasibility and cost effectiveness of an “above code” ordinance for residential pool heating. This ordinance proposes newly constructed heated pools to be heated with site-solar or recovered energy, and/or a HPPH. Specifically, this report looks at the cost-effectiveness of HPPHs as compared to the largely incumbent gas heater in the residential sector. As displayed in Table 3, there is a significant opportunity to reduce greenhouse gases using HPPHs and the measure can be cost-effective depending on certain assumptions and variables. Fortunately, HPPHs are not an emerging technology and enjoy a long-term track record of energy savings success in other major pool markets. Established manufacturers, training resources and supply chains make HPPHs an attractive energy savings and GHG reduction opportunity. As technology improves and as utility rates change, the value proposition of HPPHs is likely to become increasingly attractive over time.

In conclusion, this report has identified a cost-effective option to meet above-code performance levels for pool heating in the City of Santa Monica that could be evaluated further for potential adopted by other cities and counties within investor-owned utility territories across California.

4 References

- AHRI. (2019, August 15). *Heat Pump Pool Heater Certification*. Retrieved from Air-Conditioning Heating and Refrigeration Institute: <http://www.ahrinet.org/HPPHcertification>
- Brookhaven National Laboratory. (2009, January). *Performance Study of Swimming Pool Heaters*. BNL-93715-2009-IR. Retrieved from <https://www.bnl.gov/isd/documents/73878.pdf>
- CA IOUs. (2019, August 1). *California Investor Owned Utilities Residential New Construction Cost-effectiveness Study*. Retrieved from Local Energy Reach Codes: https://localenergycodes.com/download/800/file_path/fieldList/2019%20Res%20NC%20Reach%20Codes
- California Energy Commission. (2018, December). *Mandatory Requirements for Pool and Spa Systems and Equipment. Title 24 Part 6 Section 110.4*. Retrieved from <https://ww2.energy.ca.gov/2018publications/CEC-400-2018-020/CEC-400-2018-020-CMF.pdf>
- California Energy Commission. (2019, May). *Title 20 Appliance Standards*. Retrieved from <https://ww2.energy.ca.gov/2019publications/CEC-140-2019-002/CEC-140-2019-002.pdf>
- Code of Federal Regulations. (2019, August 15). *Appendix P to Subpart B of Part 430—Uniform Test Method for Measuring the Energy Consumption of Pool Heaters*. Retrieved from <https://www.ecfr.gov/cgi-bin/text-idx?SID=f01078cf11fc9bd68b4cce765b1551e8&mc=true&node=pt10.3.430&rgn=div5>
- Department of Energy. (2010, April 16). *Energy Conservation Standards for Residential Water Heaters, Direct Heating Equipment, and Pool Heaters*. Retrieved from <https://www.federalregister.gov/documents/2010/04/16/2010-7611/energy-conservation-program-energy-conservation-standards-for-residential-water-heaters-direct>
- InyoPools.com. (2019, August 14). *Pool Heaters*. Retrieved from http://www.inyopools.com/category_heaters.aspx



- KEMA. (2010). *California Statewide Residential Appliance Saturation Study (RASS) Database*. Retrieved from <http://websafe.kemainc.com/rass2009/Default.aspx>
- MAEDbS. (2019, August 15). *Modernized Appliance Efficiency Database System*. Retrieved from California Energy Commission: <https://cacertappliances.energy.ca.gov/Pages/ApplianceSearch.aspx>
- PG&E and Sempra Energy. (2007, February 19). *Draft Report Residential Swimming Pools Codes and Standards Enhancement Initiative (CASE) Report*. Retrieved from <https://efiling.energy.ca.gov/GetDocument.aspx?tn=46132&DocumentContentId=35298>
- Pool Center. (2019, August 8). *Pool heater sizing guide*. Retrieved from <https://www.poolcenter.com/heatersWhatSize>
- Raypak Inc. (2019, August 15). *Pool and Spa Heaters*. Retrieved from <https://www.raypak.com/pool-and-spa/>
- U.S. Climate Data. (2019, August 5). *Santa Monica, CA*. Retrieved from <https://www.usclimatedata.com/climate/santa-monica/california/united-states/usca1024>



Appendix A – Cost Effectiveness Details

Table 5: Cost-effectiveness Details

	Heat Pump Pool Heater	Right-Sized Natural Gas Pool Heater	Large-Sized Natural Gas Pool Heater
Representative Unit Input Capacity (BTU-hr)		135,000	266,000
Representative Unit Output Capacity (BTU-hr)	110,000	111,000	218,000
Coefficient of Performance	4.8		
kWh/year	1,377		
Thermal Efficiency		82%	82%
therms/ year		277	277
Equipment Lifetime	10	10	10
Representative Equipment Cost	\$ 2,895	\$ 1,426	\$ 1,832
Incremental Electrical/ Gas Equipment Costs	\$ 5	\$ 200.00	\$ 200.00
Total Capital Cost	\$ 2,900	\$ 1,626	\$ 2,032
BTUs/ \$ (year one)	86,415	63,318	63,318
10 Year NPV of Energy Costs	\$ 2,419	\$ 3,525	\$ 3,525

Source: (InyoPools.com, 2019), (MAEDbS, 2019), (KEMA, 2010)

Table 6: Customer Utility Life-cycle Costs

Year	Gas Pool Heater			Heat Pump Pool Heater		
	\$/ Therm	Therms/ year	Cost/ year	\$/ kWh	kWh/yr	Cost/ year
2020	\$ 1.30	276	\$ 357.17	\$ 0.19	1377	\$ 261.70
2021	\$ 1.35	276	\$ 371.89	\$ 0.19	1377	\$ 266.94
2022	\$ 1.40	276	\$ 387.21	\$ 0.20	1377	\$ 272.28
2023	\$ 1.46	276	\$ 402.70	\$ 0.20	1377	\$ 277.72
2024	\$ 1.52	276	\$ 418.80	\$ 0.21	1377	\$ 283.28
2025	\$ 1.58	276	\$ 435.56	\$ 0.21	1377	\$ 288.94
2026	\$ 1.60	276	\$ 439.91	\$ 0.21	1377	\$ 294.72
2027	\$ 1.61	276	\$ 444.31	\$ 0.22	1377	\$ 297.67
2028	\$ 1.63	276	\$ 448.75	\$ 0.22	1377	\$ 300.64
2029	\$ 1.64	276	\$ 453.24	\$ 0.22	1377	\$ 303.65

Source: (MAEDbS, 2019), (KEMA, 2010), (CA IOUs, 2019)

