

DOCKETED

Docket Number:	19-MISC-04
Project Title:	Modeling Tool to Maximize Solar + Storage Benefits
TN #:	228702
Document Title:	Presentation - Modeling Tools to Maximize Solar + Storage Benefits
Description:	N/A
Filer:	Liet Le
Organization:	Energy+Environmental Economics
Submitter Role:	Public
Submission Date:	6/6/2019 4:11:30 PM
Docketed Date:	6/6/2019



Energy+Environmental Economics

Modeling Tools to Maximize Solar + Storage Benefits

CEC Solar + Storage Tool

Public Workshop

06/13/2019

Jasmine Ouyang



Agenda

- + Project Scope and Schedule**
- + Tool Overview**
- + Use Cases Discussion**
 - Investment analysis:
 - Customer sited PV + Storage
 - Community/FTM PV + Storage
 - Distribution investment deferral
 - Tariff and program analysis
- + Q&A**



About E3

- Founded in 1989, E3 is an industry leading consultancy in North America
- E3 operates at the nexus of energy, environment, and economics
- Our team employs a unique combination of economic analysis, modeling acumen, and deep institutional insight to solve complex problems for a diverse client base

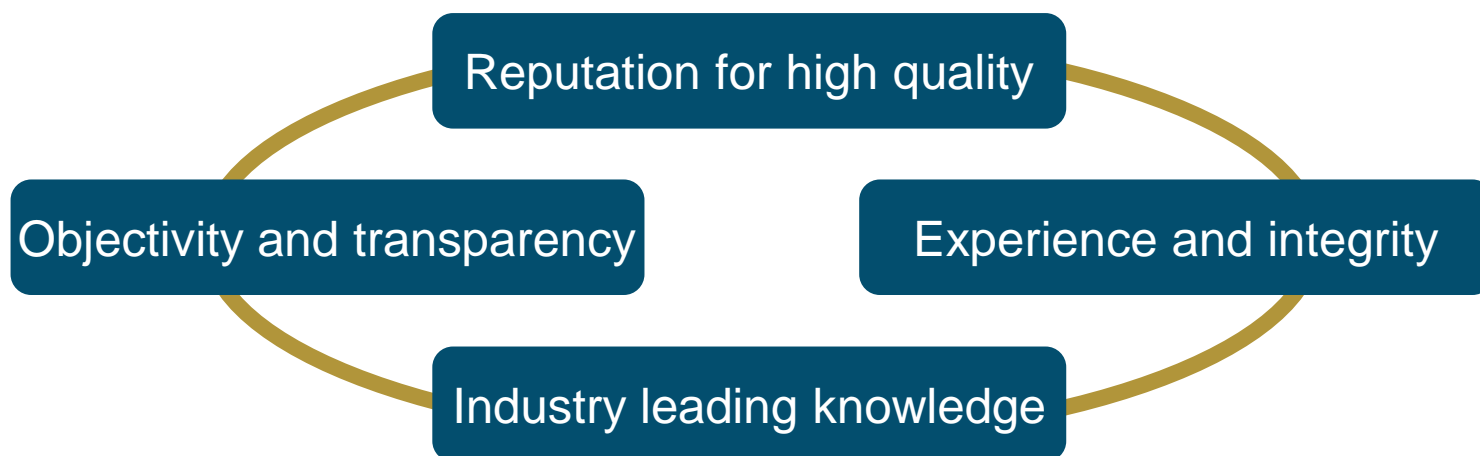



E3 Practice Areas

DERs & Rates

Analyzes distributed energy resources, emphasizing their costs and benefits now and in the future

Supports rate design and distribution system planning

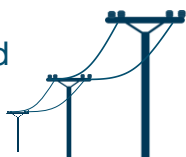

E3 has five defined working groups that create continual innovation from cutting edge projects and constant cross-fertilization of best practices across the groups

Clean Energy

Provides market and policy analysis on clean energy technologies and climate change issues

Includes comprehensive and long-term GHG analysis

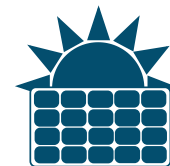

Asset Valuation

Determines asset values from multiple perspectives

Uses proprietary in-house models and in-depth knowledge of public policy, regulation and market institutions



Planning

Develops and deploys proprietary tools to aid resource planners

Informs longer-term system planning and forecasting



Market Analysis

Models wholesale energy markets both in isolation and as part of broader, more regional markets

Key insights to inform system operators and market participants





Project Overview: EPC-17-004

+ Project Purpose

- Develop the Solar + Storage Tool that assesses the cost effectiveness of PV, storage, and other DER technologies for customers and ratepayers under different tariff and program designs
 - Simulate the operation of dispatchable DERs based on an optimization algorithm
 - Estimate value with a focus on location of the resource (Local Net Benefits Analysis (LNBA))
- Apply the tool to evaluate solar + storage systems being researched in other EPIC projects (GFO-16-309)
 - Results will be shared in the next workshop



Project Schedule

+ The tool is available for download in this website:

- https://www.energy.ca.gov/research/mod_tool_max_solar_storage/
- User guide is also available, which contains a quick-start guide along with full instructions and methodology documentation
- Pre-loaded example cases
- No installation required

+ Three workshops

- Today: **Tool and use cases overview**
- August 2019: **Lessons learned and results from three EPIC projects**
- December 2019: **Final project presentation and wrap-up**

+ Webinars if needed:

- After the first workshop: follow-up conversations on the use cases
- After the second workshop: follow-up conversations on lessons learned and results from three EPIC projects



CEC Solar + Storage Tool Objectives

- + Co-optimize dispatch of storage with other DER
- + Nesting modeling of local distribution benefits
- + Quickly screen for most cost-effective technologies
- + Evaluate and size portfolio of DER for distribution deferral
- + Financial pro-forma and cost-benefit metrics for utility, customer, aggregator and project developer

- + CPUC GHG working group used OSESMO to model storage dispatch



<https://github.com/RyanCMann/OSESMO>

- + EPRI StorageVET 2.0 is in Beta release

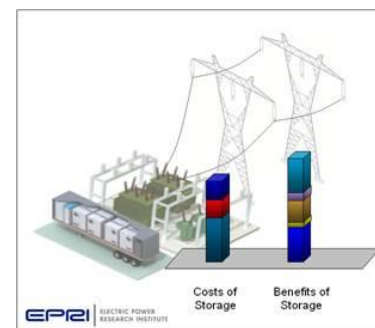

<https://www.storagevet.com/>



How the model can be used

User	Questions to answer
Utility/ Policy Maker	Distribution bottleneck screening: Where are my distribution 'hot spots'? How much value do I see in each area?
	Local Net Benefits Analysis (LNBA) of DER portfolios: How much value can the DER portfolio provided to my system (distribution deferral and system avoided costs)?
	DER Program Design: How would I design my programs to maximize value? Do I have 'missing money' that would make it hard to attract participants?
	Bid Evaluation: Which DER bids/portfolios are most cost-effective in competitive solicitations (aka non-wires alternatives)
Developer/ Aggregator	Cost-benefit evaluation of individual technologies and DER portfolios from stakeholder perspectives. What is my expected return on investment, customer payback and value to the utility?



Tool Overview

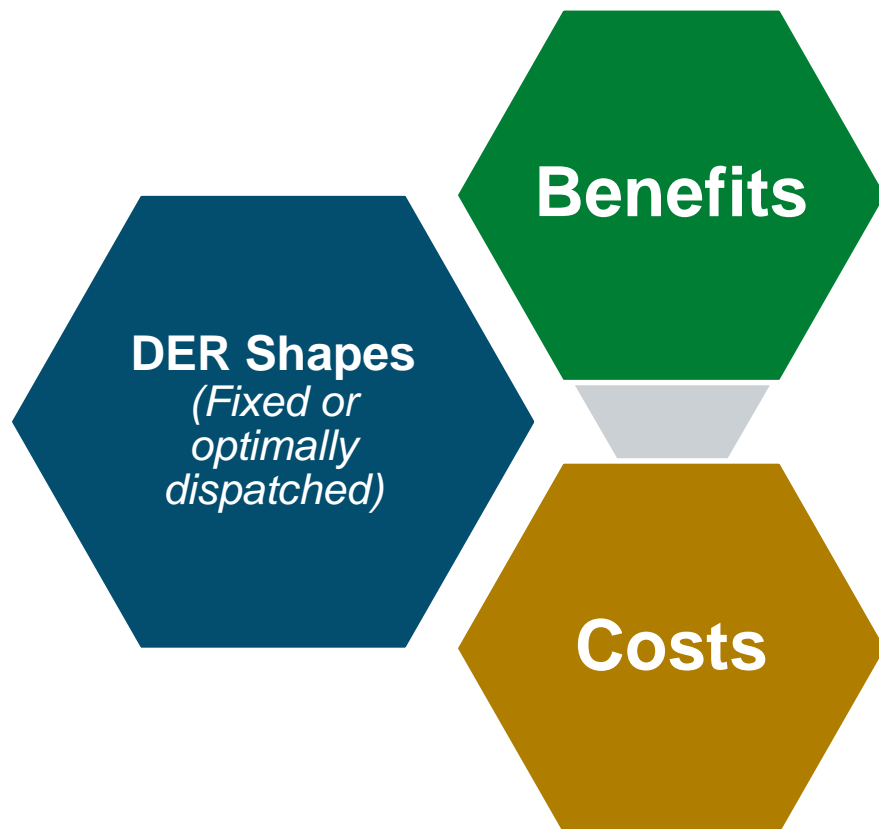

+ Benefits

- Revenues and savings

+ Costs

- Capital and O&M costs
- Financing costs
- Taxes and Incentives

+ DER Shapes

- Optimized dispatch shapes for dispatchable DERs
- Fixed DER shapes based on region and customers (e.g. PV and EE)



Benefits

+ A wide range of benefit streams can be modeled

- The model is able to calculate and co-optimized against them – it is critical for value stacking

+ Benefit combinations

- Commonly used benefit combination for each use case is pre-defined
- Users can also mix and match and pick their own benefit streams

+ Other highlights

- Flexible rate and utility program design
 - E.g. multi-tiered TOU demand charge, daily demand charge, real time rate, asymmetric energy charges, volumetric payment for demand response, etc.
- Project-specific T&D Deferral Values (LNBA Style)

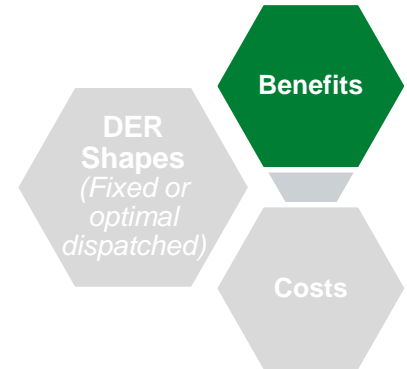

Customer sided
<ul style="list-style-type: none"> • Demand charge management • TOU energy charge management • Utility Program Revenue (e.g. DR program) • Back-up power

Distribution System
<ul style="list-style-type: none"> • Project specific T&D deferral • Interconnection costs reduction • Reliability • System avoided costs or Bulk system revenues

Bulk System
<ul style="list-style-type: none"> • Resource adequacy program • Wholesale energy market • Ancillary services revenue • Project specific transmission deferral • Renewable firming services



+ A Pro Forma is integrated into the model to calculate the all-in project costs, including:

- Capital costs
- Operating and maintenances costs
- Financing costs
- Incentives
 - Self-Generation Incentive Program (SGIP)
 - Investment Tax Credit (ITC)
- Taxes

+ Two financing options:

- Self-financing with the ability to specify a debt and equity ratio
- Third-Party Leasing

+ Users can also overwrite with their own cost estimate

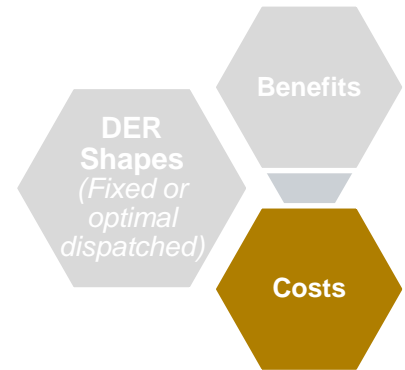



DER Shapes

+ Dispatchable

- Objective function: minimizing net costs
- Subject to technology, market, and incentive (e.g. ITC) constraints
- Co-optimization across multiple technologies with perfect foresight
- Price taker

+ Partial Dispatchable

- Dispatch with the consideration of customer comfort level
- Co-optimize with both dispatchable and partial dispatchable technologies

+ Fixed shapes

- User input based on the specific project or customer
- Default PV shapes pre-loaded for each climate zone

Other highlights

- Temperature-based day mapping
- Flexible Optimization Window (Daily, Monthly, Annual) and Intervals (Hourly, 15mins, 5mins)

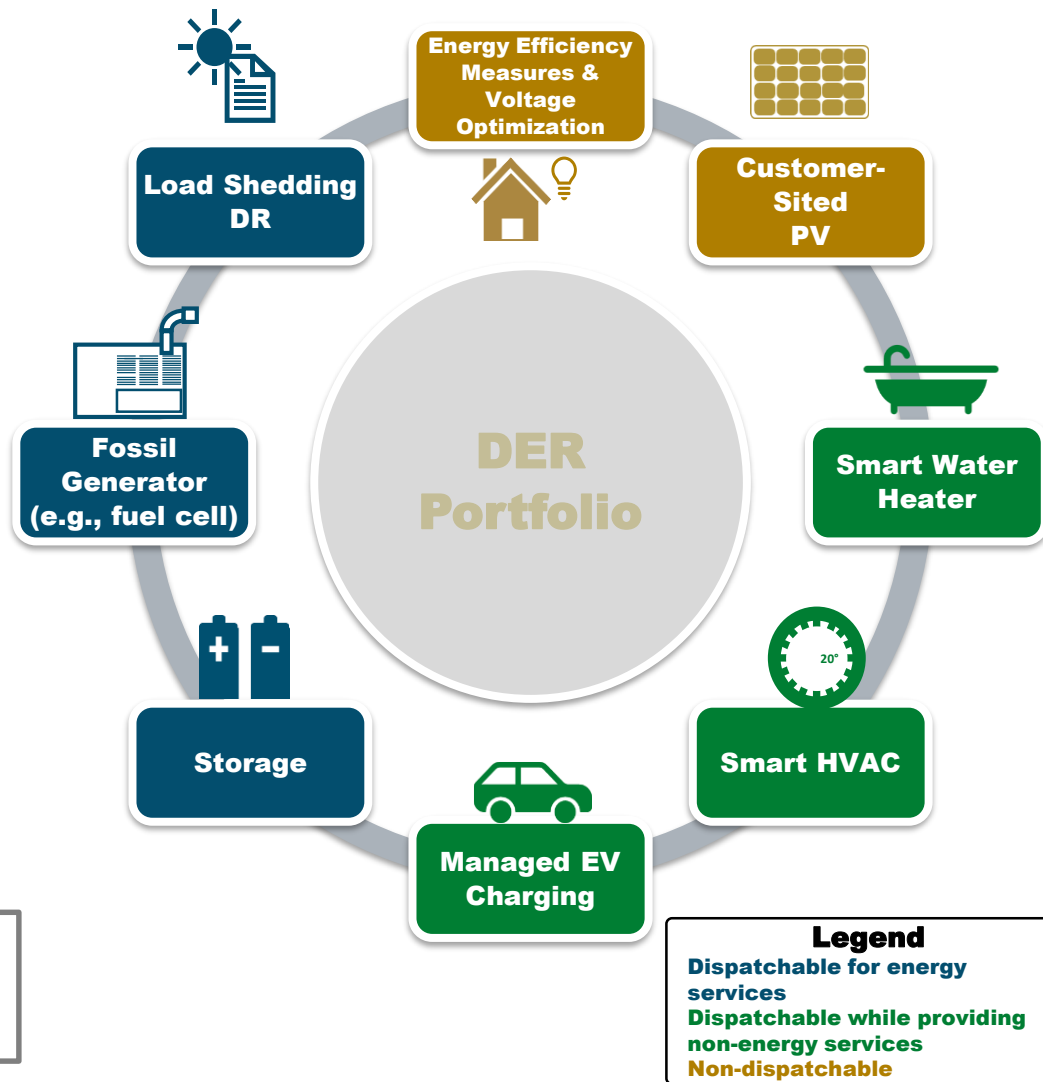



Individual Level

DER Portfolio

- Distribution investment deferral
- Smart home operation

DR

- DR value study

EE

- System and local EE potential and cost-effectiveness study

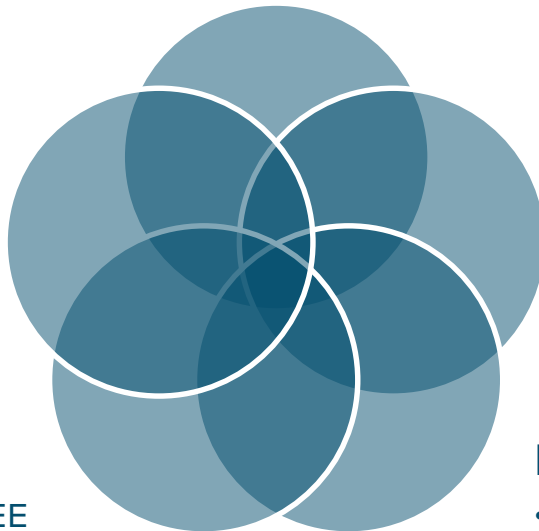

EV

- Managed Charging and V2G Benefits Analysis

PV + Storage

- Investment analysis
- Peaker replacement
- Transmission and Distribution deferral

State & Utility Level

Today's focuses

All DERs

- Tariff and program analysis
- SGIP program evaluation
- Distribution bottleneck screening
- Electrification study



Energy+Environmental Economics

Investment analysis



Background

- + **This tool can inform investment decisions for customer sited and front of the meter PV + Storage projects:**
 - performing detailed analytical simulations to model and co-optimize/stack the potential revenue streams the storage project could access over a 20-year period
 - providing a detailed financial analysis for project investors and lenders
- + **Scenario analysis can be done easily in the tool to investigate different sizing options and bookend cases**
- + **Future utility rates, energy, capacity, and ancillary services prices are inputs to the model**



Picture source: <https://pv-magazine-usa.com/2019/01/02/utility-scale-solar-power-plus-lithium-ion-storage-cost-breakdown/>



Customer sited PV + Storage

Use Case Parameters

Location: SCE
Type: Commercial Customer
Tariff: SCE TOU-8
Configuration: Paired with onsite load
PV Specs: 30 kW
PV Costs: \$3,080/kW
Battery Specs: 10 kW, 4 hr
Battery Cost: \$762/kWh

Value Streams:
 - Bill Savings

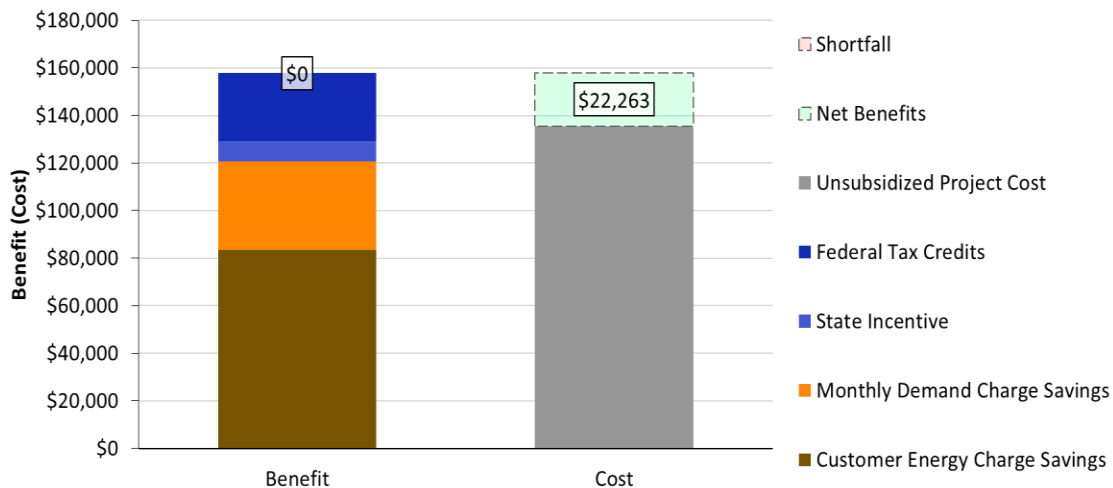

Results & Analysis: 10-Year Lifetime Levelized

Benefits (\$/kW-yr \$)	Costs (\$/kW-yr \$)	BCA Ratio	ROE (%)
\$536 \$157,833	\$460 \$135,570	1.16	12%

*\$/kW-yr is calculated as \$/PV's installed capacity per year
 Results are from the model pre-loaded case: BTM Bill Savings



FTM PV + Storage

Use Case Parameters

Location: SP15
PV Specs: 1 MW
PV Costs: \$1,288/kW
Battery Specs: 1 MW, 2 hr
Battery Cost: \$453/kWh

Value Streams:

- Energy arbitrage
- Capacity value
- Ancillary services revenue

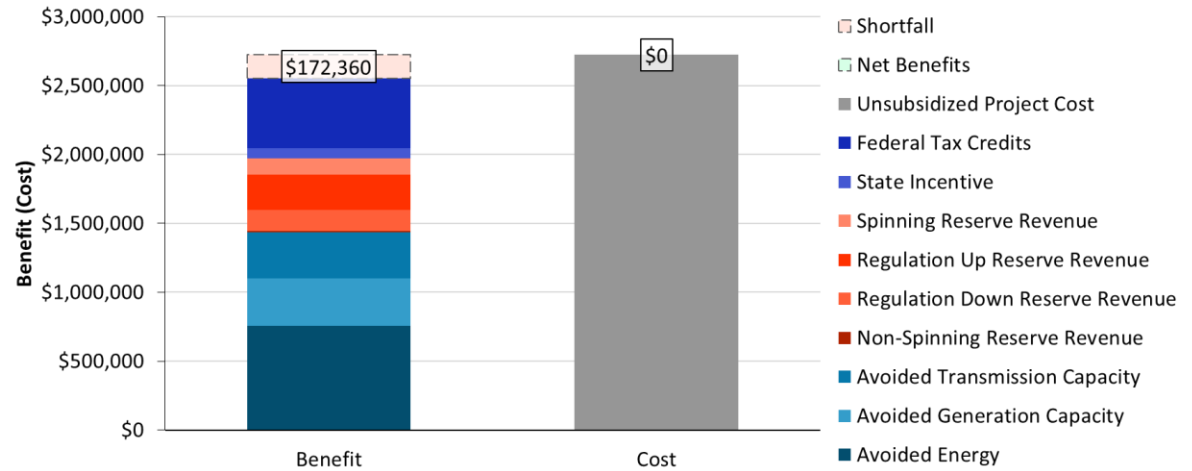

Results & Analysis: 10-Year Lifetime Levelized

Benefits (\$/kW-yr* \$)	Costs (\$/kW-yr* \$)	BCA Ratio	ROE (%)
\$257 \$2,541,380	\$277 \$2,723,740	0.94	9%

*\$/kW-yr is calculated as \$/PV's installed capacity per year
 Results are from the model pre-loaded case: FTM Wholesale



FTM PV + Storage - Lifetime Annual Revenue Projection

- + The tool dispatches storage against the future capacity, energy, and ancillary services prices
- + Lifetime annual revenue is projected:

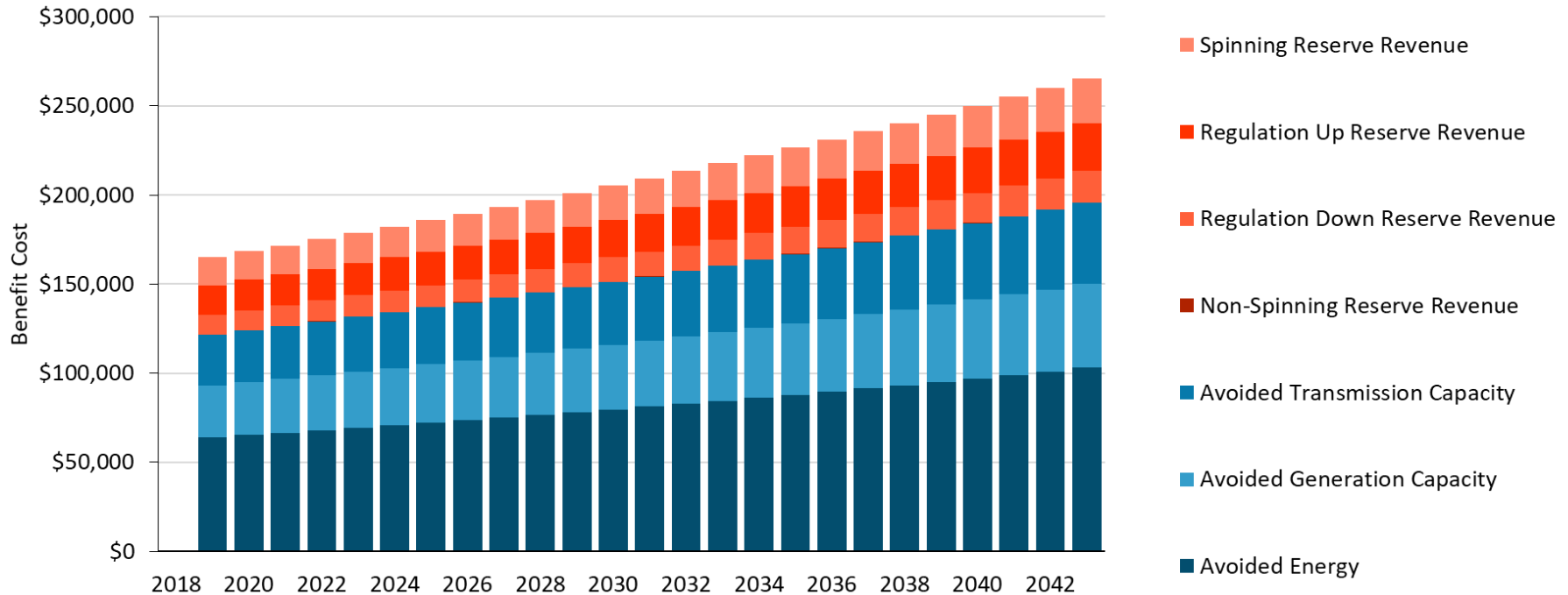

Results are from the model pre-loaded case: FTM Wholesale



FTM PV + Storage - Example Dispatch

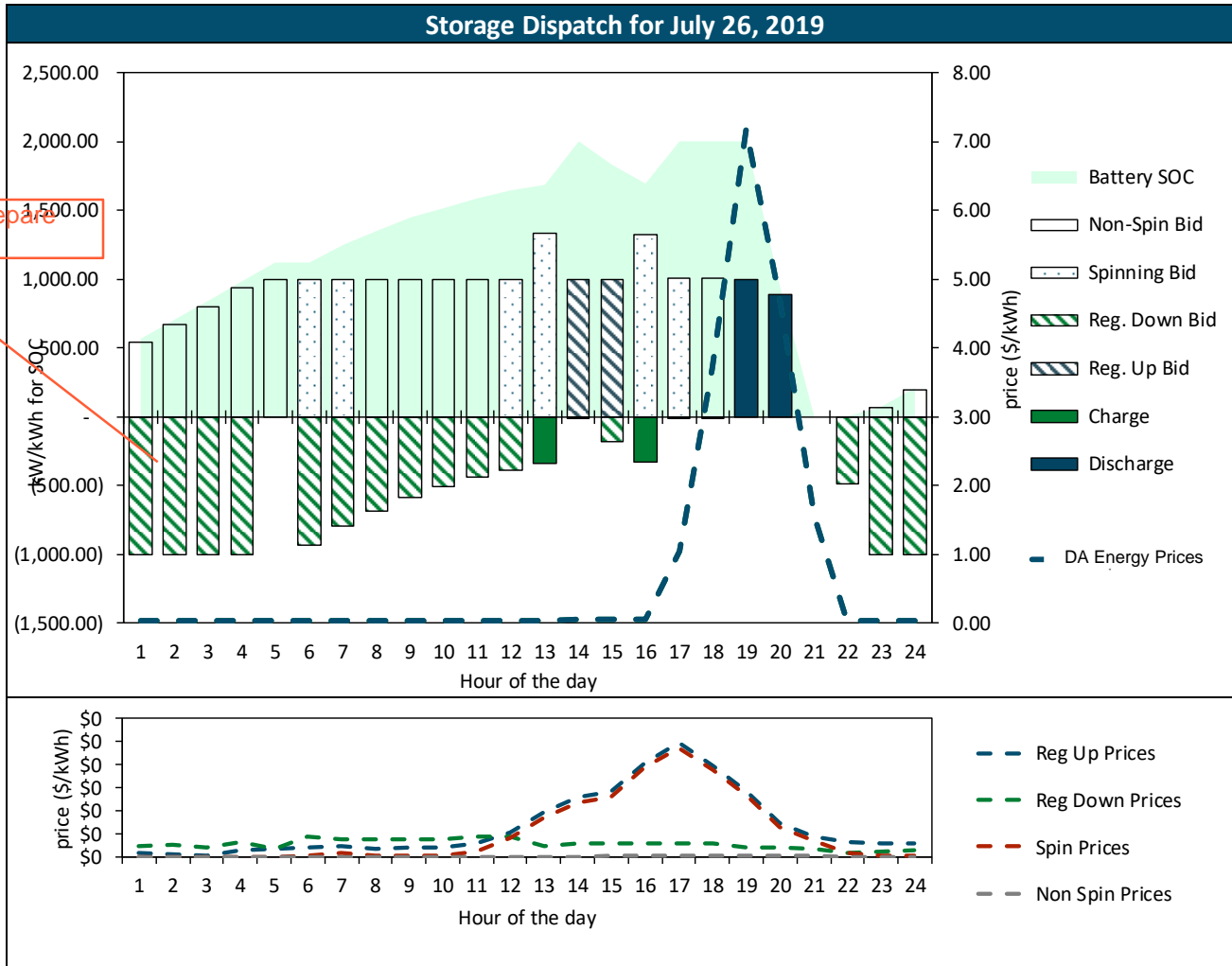

Results are from the model pre-loaded case: FTM Wholesale



Net Present Values by Scenarios

+ Example lifetime financial analysis – Net Market Value

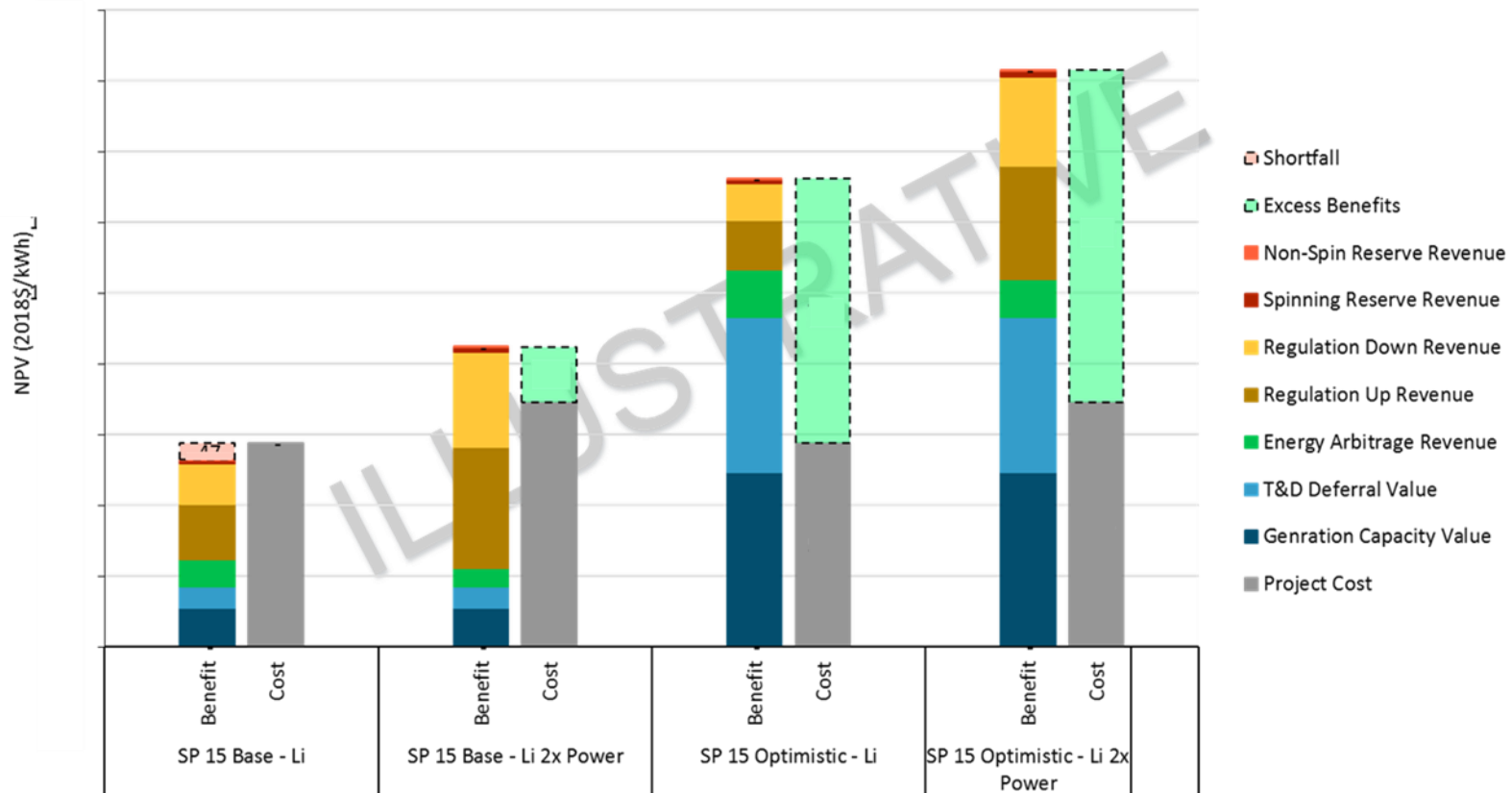



Compare multiple sizing options

Case Name		Base	Large Battery	Large PV	Large PV + Battery
PV (kW)		260	260	520	520
Storage* (kWh)		200	800	200	800
TRC	Benefit	\$974,955	\$1,214,180	\$1,842,130	\$2,021,770
	Cost	\$836,093	\$1,243,201	\$1,531,465	\$1,938,573
	B/C Ratio	1.17	0.98	1.20	1.04
RIM	Benefit	\$721,088	\$760,305	\$1,402,299	\$1,378,909
	Cost	\$1,211,252	\$1,308,775	\$2,039,236	\$2,195,805
	B/C Ratio	0.60	0.58	0.69	0.63
PCT	Benefit	\$1,246,341	\$1,506,904	\$2,115,255	\$2,427,270
	Cost	\$733,053	\$1,083,786	\$1,344,966	\$1,695,699
	B/C Ratio	1.70	1.39	1.57	1.43

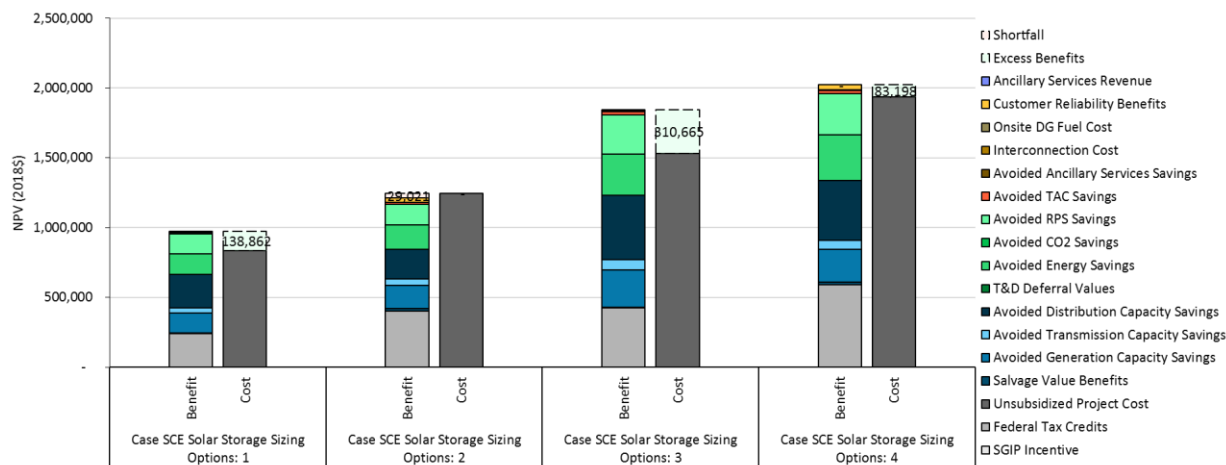

* All batteries are 4-hour battery in this example



Energy+Environmental Economics

Distribution Investment Deferral



Background

- + **DERs can serve as non-wires alternatives for local capacity projects if they can reliably reduce the local peak constraints**
- + **Key points in assessing this value:**
 - Lumpiness: the values can only be realized when a project is avoided or deferred, there is no 'partial credit' for reducing 99% of the required peak load reduction
 - Interaction among different type of DERs: storage might not need to discharge if PV, EE, and EV managed charging can provide peak load reduction cheaply
 - Reliable peak load reduction: how to translate the simulated peak load reduction to include uncertainty in both peak load and DER response
 - Other potential revenue streams: the DER system can provide other services when there is no peak reduction need from the distribution system, but stacking benefits comes with constraints and different rules on dual market participation
 - Nesting Impact: The DER system may affect both a distribution and transmission constraint, so the model allows 'nested' areas and dispatch that considers both
- + **Implements the LNBA approach used in the California DRP to assess the local value of constraints based on the utility traditional distribution upgrade and planning data**



Example Case

+ Rector – Riverway No.2 66 kV - New Circuit: add 1 12kV Circuit

- Based on information from SCE 2018 GNA and DDOR reports

Upgrade Project Info	
Location Name	Rector – Riverway No.2 66 kV
Upgrade equipment type	Substation
Upgrade capital cost (\$)	\$27,410,000
Project commission year	2021

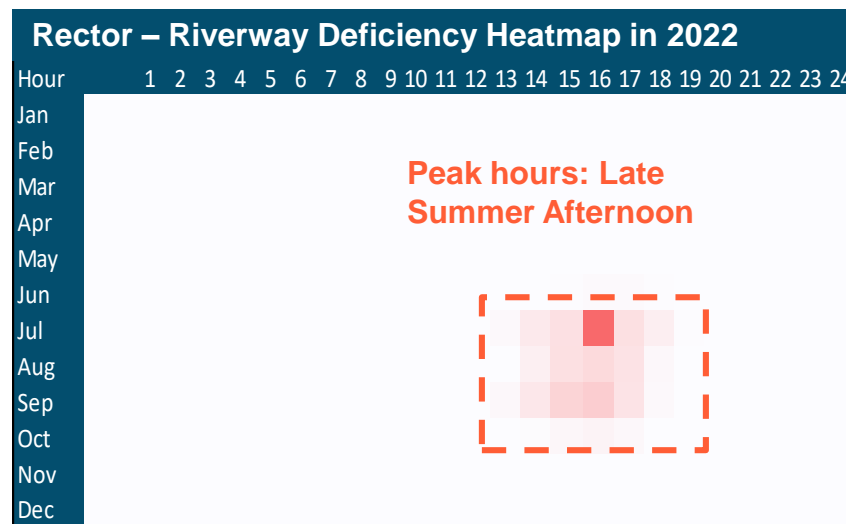
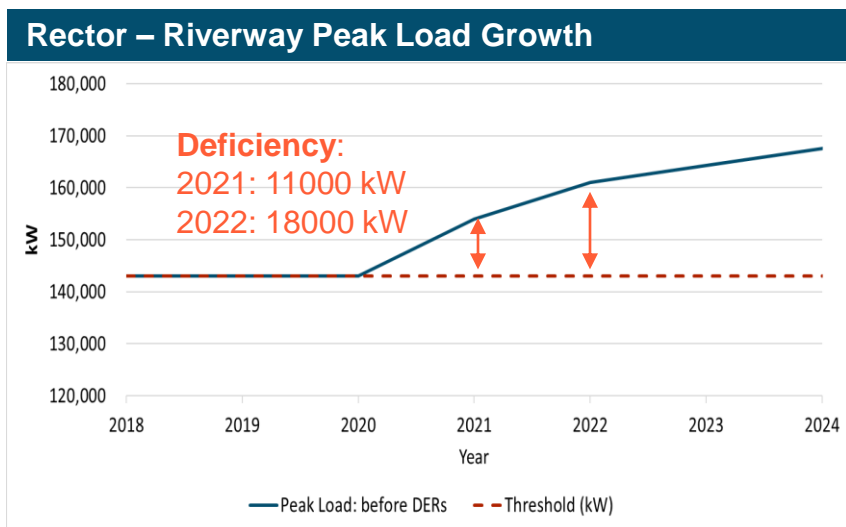

*E3 assumptions: RR multiplier: 1.6, inflation rate: 2%; book life: 30 years; Deficiency forecasts: 2018 – 2022: based on the GNA report; after 2022: escalate at 2% per year; load shapes is based the DPA1 load shape in the LNBA tool, it is scaled to match the rating and deficiency reported in the GNA report

Results are from the model pre-loaded case: Deferral



Technology Screening

+ One step before deciding on a DER portfolio

- screening for suitable technologies

Total Avoided Costs + AS Revenue for all screened technology



*kWh is defined as annual total generation/discharge
 Results are from the model pre-loaded case: Rector Screening



+ Consider using the following DER portfolio to defer the upgrade

- PV: 10000 kW DG PV
- Storage: 10000 kW 2-hour Battery
- EE: Average 400 kW HVAC Energy Efficiency
- DR: 2000 kW Load Shedding Demand Response
 - maximum 10 calls per year with maximum 4 hours per call
- EV: Managed charging for 4 BEV 250 vehicles using 6.6 kW level 2 chargers

+ Assume the DER portfolio is installed in 2020 to allow one year lead time for deferring decision



Deferral Values

+ The DER portfolio

- Provides total 198 kW peak load reduction
- Defers the upgrade from 2021 to 2023
- Results in \$12 Million Deferral Value

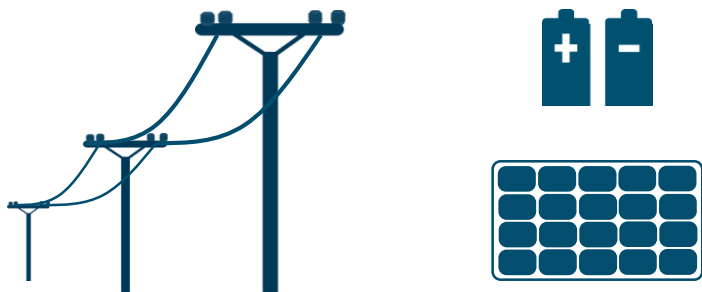

Item	2021 Peak Load Reduction (kW)	Deferral Values (\$2021)
Total	18,177	12,234,335

Circuit 1107 – Peak Load before and after

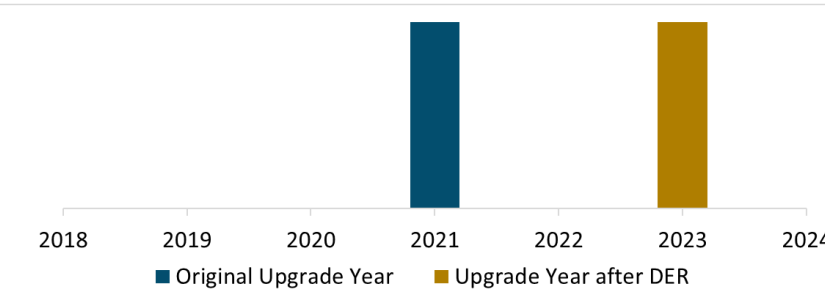
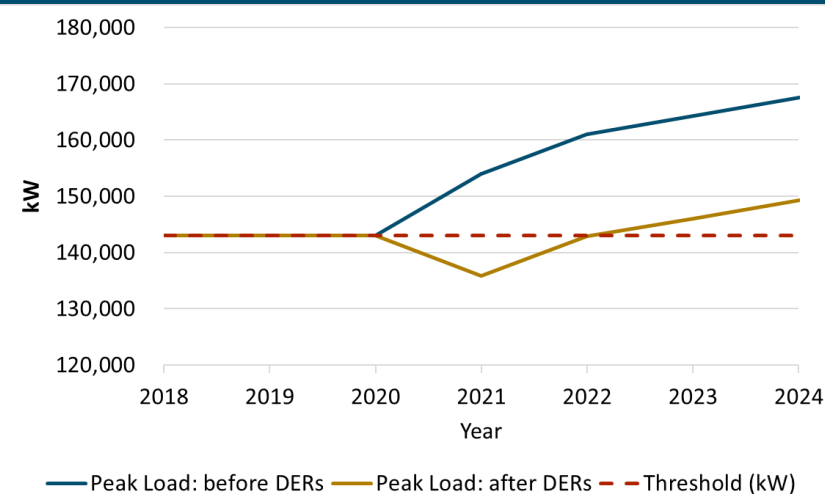

Results are from the model pre-loaded case: Deferral



Peak Day Snapshots

- + PV, EE, DR, and storage all contribute to the reduction of the afternoon peak
- + The EV charging hours are already during off-peak hours (overnight) before managed charging, thus EV managed charging doesn't contribute to the peak reduction

Peak Day: Before and After DER

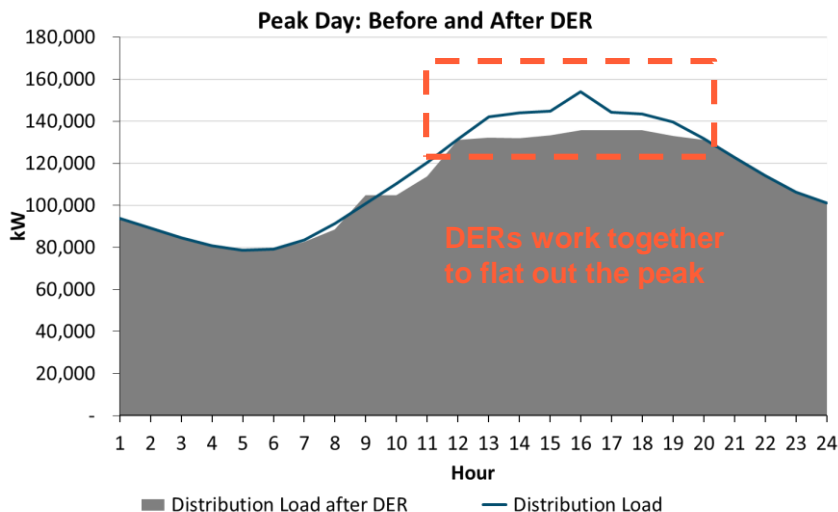

Peak Day: DER Contribution

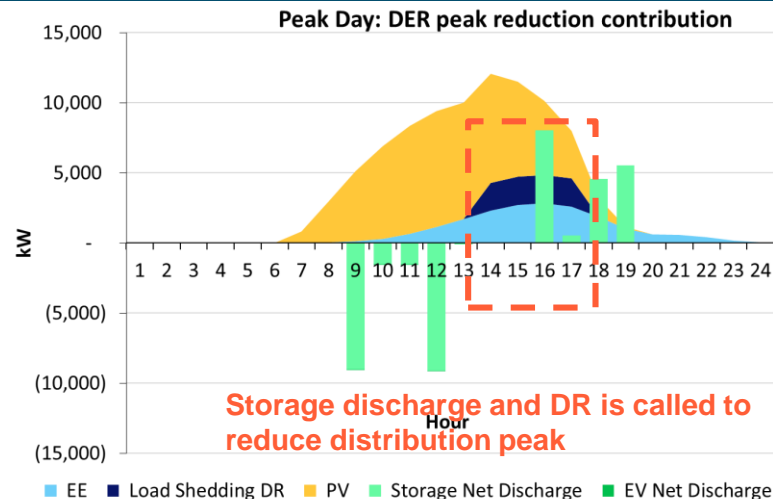

Results are from the model pre-loaded case: Deferral

Peak day: 7/18



Project NPV Summary

+ In addition to provide deferral value, the DER portfolio is also able to provide other system values in non-peak hours

Total system benefits provided by the DER portfolio

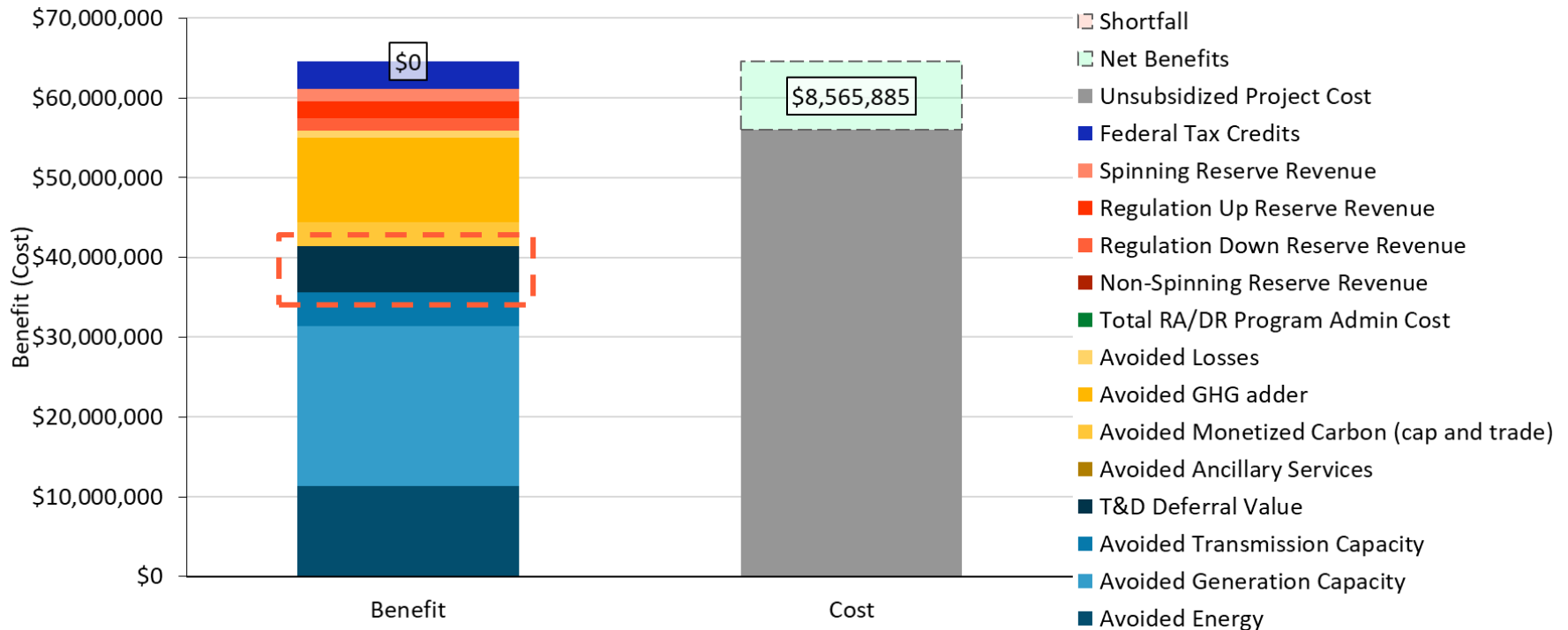

Results are from the model pre-loaded case: Deferral



Nesting Impact

+ Nesting impact can be taken into account

- If DER is installed in Circuit 1107, in addition to defer the upgrade in Circuit 1107, it might also be able to defer the upgrade upstream (e.g. DPA 1)

Distribution Network

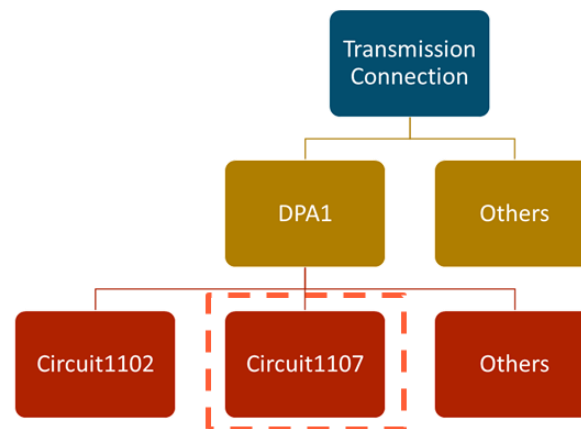

Deferral Values for DERs installed in Circuit 1107

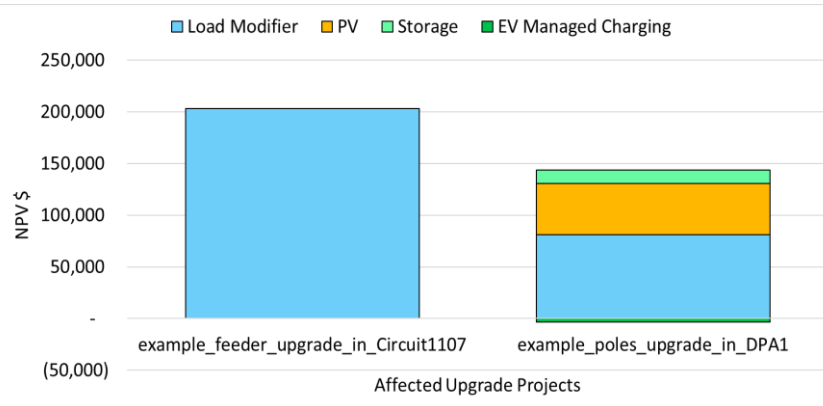



Energy+Environmental Economics

Tariff and Program Analysis



Background

- + The adoption of customer sited PV + storage are expected to grow as technology prices decline**
 - Each customer might operate their PV + storage system differently
 - Factors that influence operations include rates, customer load, need for back-up power
 - PV + storage are valuable energy resources to the system but in particular energy storage must be aligned to system need to provide system benefits
- + Questions from regulators and utilities:**
 - How should utility and state rates/programs be designed to maximize value?
 - What are the system/utility storage avoided costs by component?
 - What is the bill savings impacts for customers who install storage?
- + Example case studies:**
 - SGIP program evaluation
 - Study for 2018 will be available by the end of the June
 - New York storage roadmap
 - Describes a longer-term end-state vision and identifies deployment opportunities, use cases, and implementable actions to accelerate deployment of high-value storage applications based on hundreds of modeled use cases



It is important to understand customers' benefits

+ Customers' economic varies based on their rates and load profiles

- Customers with multiple demand charges see better storage economics due to the significant bill savings from demand charge clipping
- Peakier customers enjoys more demand charge savings as it is easier for storage to reduce peak for them

Storage breakeven cost for customers under different rates - NY Example Results*

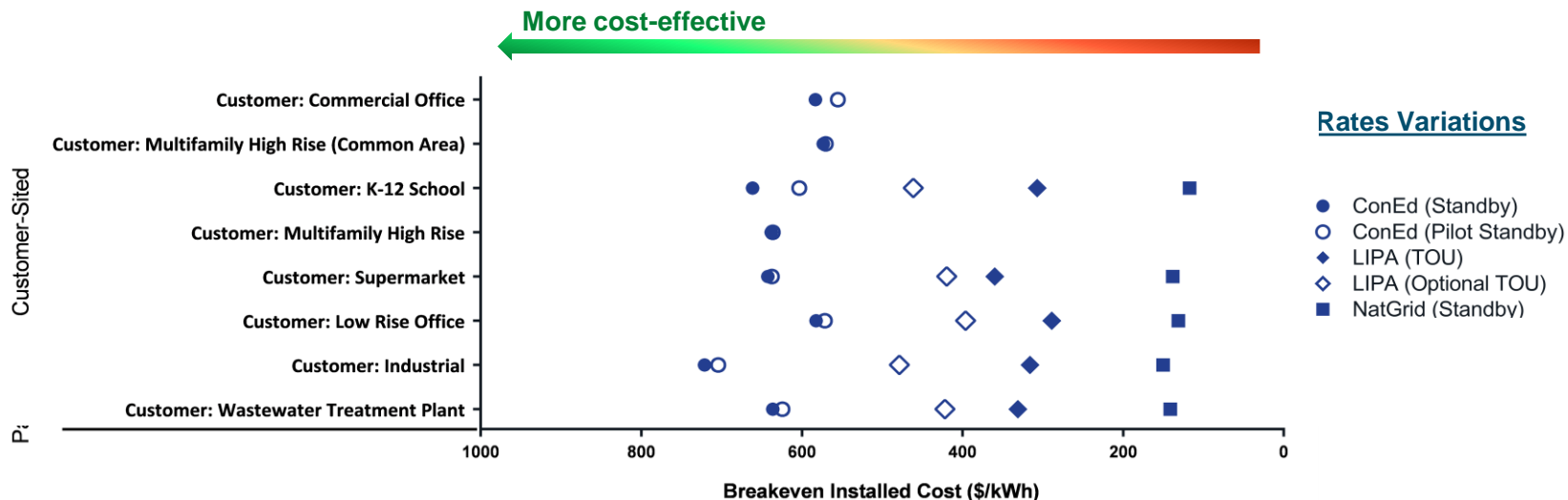

*results from NYSERDA storage roadmap report



It is important to understand storage's dispatch behavior

+ The timing for storage discharging depends on customers load

Demand Charge Impact

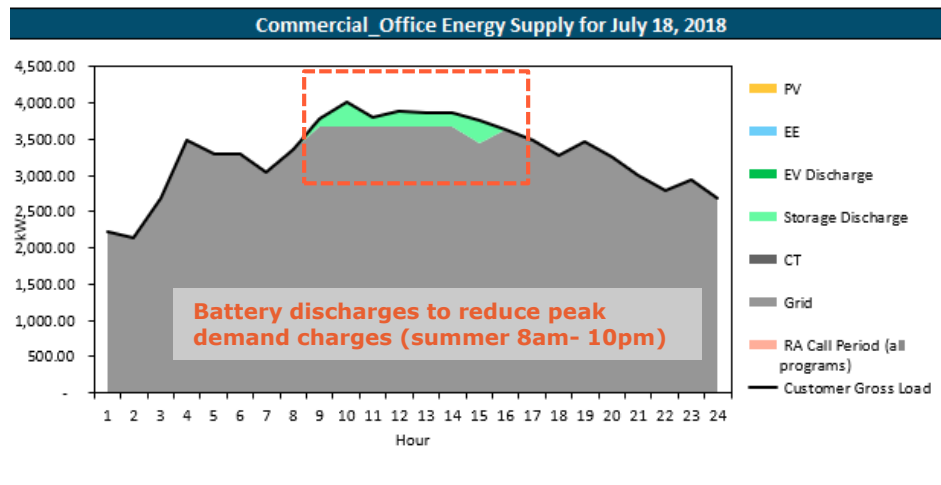
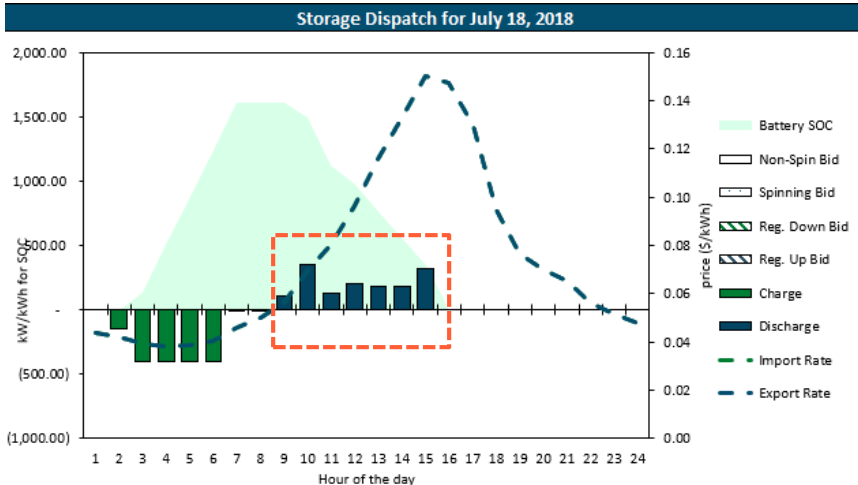

Export Rate Impact

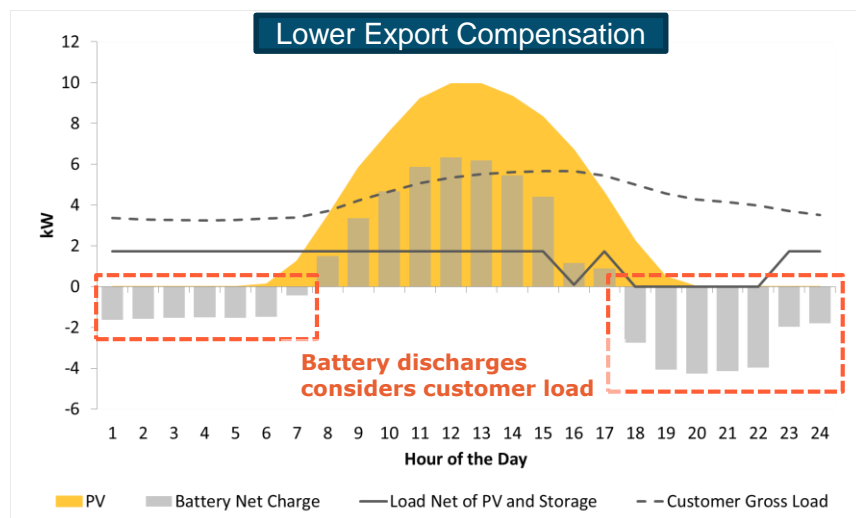
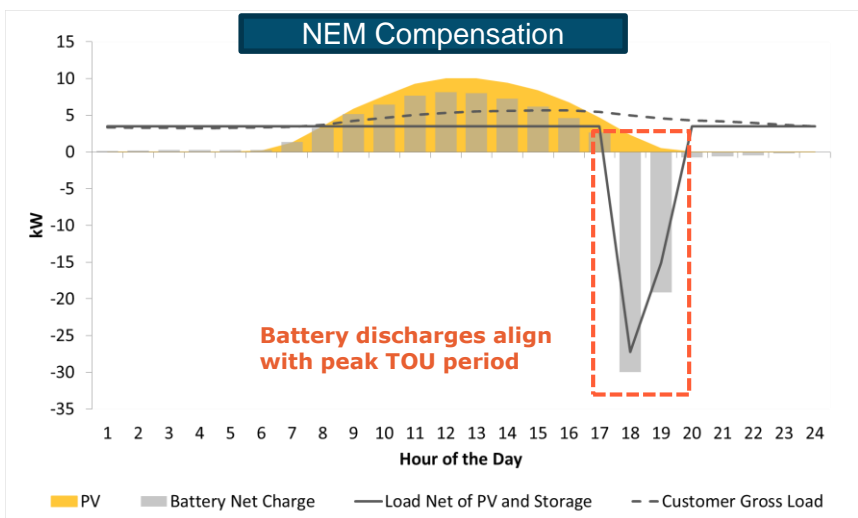

*illustrative results



Tariff and program analysis

+ Examine participant cost test (PCT) and total resources cost test (TRC) for customer and system benefits

- The rates that provide similar values to participants might result in totally different system values

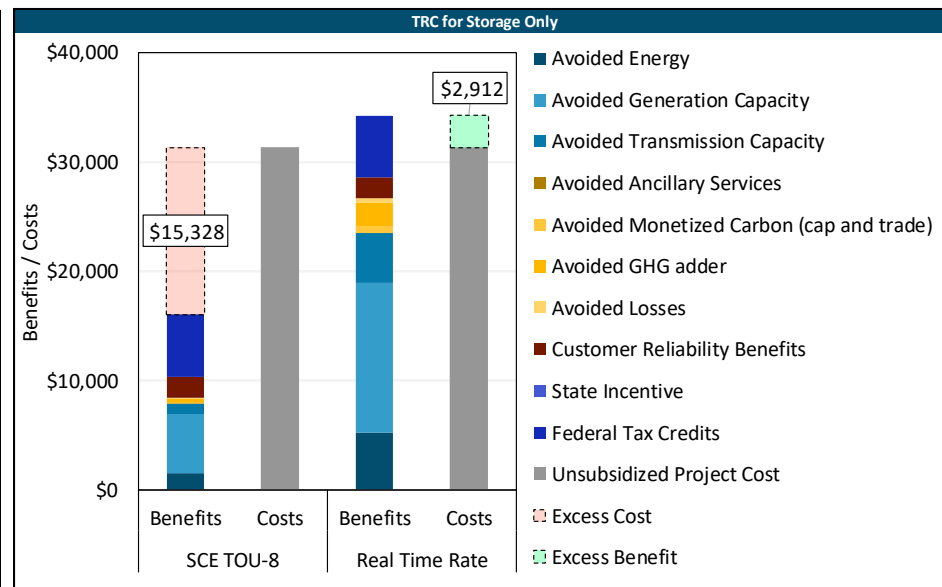
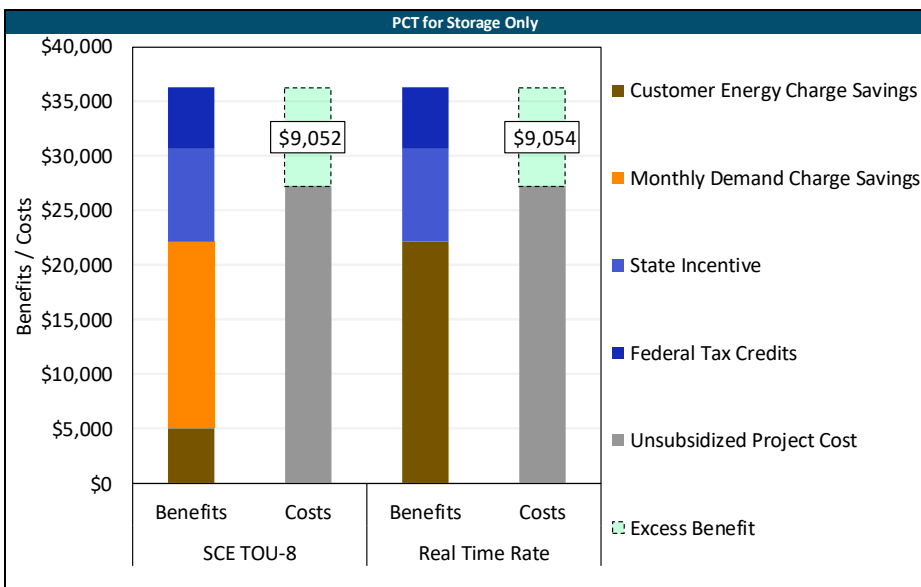

Results are from the model pre-loaded case: BTM Bill Savings



Summary

- + The tool can support in-depth economic analysis of a broad range of Solar + Storage project configurations across customer segments and rate designs**
- + Use cases include**
 - Investment decisions in Solar + Storage systems
 - Expected DER dispatch behavior under different pricing programs and assumptions
 - Cost-effectiveness of DER portfolios and the ability to 'stack benefits'
 - Non-wires alternatives assessment consistent with LNBA analysis in DRP
- + Data needed for conducting this analysis**
 - Representative customer load shapes
 - Potential rates, programs, and incentives to examine



Energy+Environmental Economics

Questions?