

DOCKETED

Docket Number:	12-AFC-03
Project Title:	Redondo Beach Energy Project
TN #:	200238
Document Title:	Connie Abela Comments: Help Stop New AES Redondo Power Plant
Description:	N/A
Filer:	System
Organization:	Connie Abela
Submitter Role:	Public
Submission Date:	8/20/2013 11:26:20 AM
Docketed Date:	8/20/2013

Comment Received From: Connie Abela

Submitted On: 8/20/2013

Docket Number: 12-AFC-03

Help Stop New AES Redondo Power Plant

Dear Ms. Kelly,

I own a condominium very close to the AES Power Plant. Along with most of the citizens of Redondo Beach, I too oppose a new power plant and feel that it would be terrible for Redondo to 1) keep the existing power plant in place and 2) build even a larger power plant because 1) the pollution it creates and will continue to cause, 2) it is an eyesore to the beauty around the vista of Redondo Beach and Hermosa Beach, plus 3) it is not needed.

Thank you for your consideration.

Connie

Connie Abela

Additional submitted attachment is included below.

ANALYSIS OF LOCAL CAPACITY REQUIREMENTS IN THE WESTERN LOS ANGELES (LA) BASIN SUB-AREA

**Study of an Environmentally Superior Alternative to
Proposed New Generation at the Redondo Beach Generating
Station for Meeting Local Capacity Requirements in the
Western LA Basin Sub-Area**



Prepared by:
Advanced Energy Solutions
Contact: Jaleh Firooz
jfirooz@iesnet.com

June 2013

Contents

	Page
Executive Summary	5
Introduction	5
Results and Conclusions.....	6
Analysis.....	12
LCR Analysis	
Probability of the need for the CAISO Calculated LCRs	
Conventional Generation Capacity	
Non-Conventional Capacity Alternatives	
Load Drop Alternative	
Other Conventional Generation Alternatives	
Power Flow Analysis	
Renewable Integration Requirements.....	21
Redondo Beach Substation and Associated Transmission Infrastructure.....	23
Appendix.....	26

Executive Summary

Introduction

In 2011, on behalf of the California Coastal Conservancy, Advanced Energy Solutions undertook an independent analysis of the need for generation at the location of the existing Redondo Beach generation facility. The analysis determined that the local reliability requirements specified by the CAISO for the Los Angeles Basin and the Western Los Angeles Basin sub-area do not require that there be any generation located at the existing Redondo Beach generation facility through year 2021. Advanced Energy Solutions also found that there are no technical studies that indicate the flexible (dispatchable) generation needed to accommodate a significant increase in intermittent renewable generation, is required to be located at the existing Redondo Beach generation facility. The 2011 analysis concluded that all generation at the existing Redondo Beach generation facility can be retired without any adverse impacts on grid reliability. Advanced Energy Solutions' report was completed in December, 2011 and can be found at <http://jfirooz.wix.com/firoozconsulting>

The 2011 report considered the CAISO's estimate of Local Capacity Requirements (LCRs) for the Los Angeles Basin and Western Los Angeles Basin sub-areas in 2021, and used forecast load growth to extrapolate/interpolate the CAISO's LCR estimates for all years of the 2012 through 2021 study horizon. The report compared these LCR estimates to the amount of existing generating resources, expected retirement of Once Through Cooling (OTC) units,¹ and expected generation additions within these areas. The 2011 report also considered the CAISO's estimates of the amount of flexible generation that would likely need to be added to the system to accommodate the integration of intermittent renewable resources through year 2021. The report noted that "incremental energy efficiency, demand response, and/or distributed generation could help further reduce the need for generation capacity in the Western LA basin sub-area."²

The City of Redondo Beach asked Advanced Energy Solutions to update its 2011 report and determine if the conclusions reached in that report are still accurate or whether changes are needed based on information that has become available since December, 2011. Specifically, the City wants to know if removing all generation and substation facilities, and all connecting transmission lines, from the existing Redondo Beach power plant, in combination with other supply and demand-side options, is environmentally superior to other alternatives for meeting California's electricity requirements (including the alternative of building new generation at the

¹ On May 4, 2010, the State Water Resources Control Board (SWRCB) adopted a statewide policy on the use of coastal and estuarine waters for power plant cooling. Approximately 30% of California's existing in-state generating capacity (gas and nuclear power) uses coastal and estuarine water for once-through cooling. This policy will impact coastal generation that does not yet comply, by requiring that generation be retrofitted, repowered, or retired.

² Page 6, "ANALYSIS OF THE NEED FOR GENERATING CAPACITY at the REDONDO BEACH GENERATING STATION, Oct 2011".

Redondo Beach location as proposed by the current owner of the Redondo Beach facility (AES)³.

Power flow analysis was performed to confirm that the supply-side and demand-side solutions⁴ discussed in this study will, if implemented, reliably satisfy the Western LA Basin sub-area Local Capacity Requirements (LCRs) identified by the CAISO.

New information has become available since the initial report was published in December, 2011. This new information includes CAISO transmission planning study results and CPUC decisions. In addition, the possible long term unavailability of the two San Onofre Nuclear Generating Station (SONGS) units in southern California became a reality following a radiation release in January, 2012.

Major sources of the data for this update include the:

- CAISO Board-approved 2012-2013 transmission plan and associated report. The CAISO's report includes the results of the CAISO's no-SONGS mitigation strategy for 2018 (mid-term) and 2022 (long-term).⁵ The report includes a summary of the results of power flow studies that back the CAISO's analysis. The CAISO's 2012-2013 transmission plan was approved by the CAISO Board on March 20, 2013. According to the associated report, the CAISO "performed a comprehensive study of the ISO transmission grid to meet California's policy goals, in addition to examining conventional grid reliability requirements and projects that can bring economic benefits to consumers." As part of this work the CAISO identified upgrades needed to meet CAISO grid reliability needs and upgrades to support achievement of the state's requirement to supply 33% of California's retail electricity consumption with renewable energy by 2020.
- LCR technical analysis reports prepared by the CAISO to estimate LCRs for years 2013 (short-term, with and without SONGS), 2014 (with SONGS) and 2018 (with SONGS). On an annual basis the CAISO determines, for the upcoming Resource Adequacy (RA) compliance year, LCRs for transmission constrained areas of the CAISO grid. These annual LCR determinations are used by the CPUC to establish CPUC-jurisdictional load serving entities' system and local RA obligations. They are used by the CAISO to

³ AES is a corporation which owns and operates power plants in the United States and internationally. Advanced Energy Solutions is an unrelated independent consulting firm located in the San Diego, California.

⁴ The demand and supply side values used in the study are based on projections developed by the CPUC and CEC and provided to the CAISO. The CAISO's analysis made certain modifications to these projections including the assembly of a "base" Renewable Portfolio Standard (RPS) scenario.

⁵ According to the CAISO: "the mid-term studies addressed the recommendations from the CEC, which were made in consultation with the CPUC, in the 2011 Integrated Energy Policy Report that 'to support long-term energy and contingency planning, the California ISO (with support from PG&E, SCE, and planning staff of the CPUC and CEC) should report to the CEC as part of its 2013 Integrated Energy Policy Report (IEPR) and the CPUC as part of its 2013 long-term procurement plan on what new generation and transmission facilities would be needed to maintain system and local reliability in the event of a long-term outage at Diablo Canyon, SONGS, or Palo Verde.'"

determine whether the CAISO needs to implement its backstop procurement authority in the event load serving entities fail to contract for generation sufficient to meet the established LCRs.

- CPUC’s February 13, 2013 *Decision Authorizing Long-Term Procurement for Local Capacity Requirements* (D.13-02-015) in the Western LA Basin sub-area which was issued as part of the CPUC’s Long Term Procurement Plan (LTPP) proceeding. While RA compliance is established by the CPUC on a one-year forward basis, the CPUC uses the Local Reliability track of the LTPP proceeding to authorize long-term procurement of generating capacity that meets projected LCRs for the years 2021 and beyond “...to the extent that the Commission finds there is such a need.”⁶ CPUC D.13-02-015 authorizes Southern California Edison Company (SCE) to procure between 1400 and 1800 megawatts of electrical capacity in the Western Los Angeles Basin sub-area of the Los Angeles Basin area to meet LCRs projected through year 2021. The CPUC decision relies heavily on information provided by the CAISO in the LTPP proceeding.

No confidential information appears in this report. To perform power flow analysis Advanced Energy Solutions used several power flow base cases to examine grid performance following selected contingencies. Certain data elements within the power flow cases are considered confidential by the CAISO.

⁶ Page 6 of CPUC Decision 13-02-015.

Results and Conclusions

In the absence of the two SONGS units, the addition of about 2000 MW of demand reduction and distributed generation, in combination with 940 MW of new generating capacity at the site of the existing Huntington Beach generating station, will satisfy LCRs in the Western LA Basin sub-area through 2022 and allow the shut down and removal of all existing generating and substation facilities at the Redondo Beach plant. In addition, a relatively minor transmission line reconfiguration at La Fresa substation will allow all four of the existing 230 kV transmission lines between the Redondo Beach substation and La Fresa substation to be de-energized and removed.

With the two SONGS units operating, the addition of less than 2250 MW of demand reduction and distributed generation will satisfy LCRs in the Western LA Basin sub-area through 2022 and allow the shut down and removal of all existing generating and substation facilities at the Redondo Beach plant. In addition, a relatively minor transmission line reconfiguration at La Fresa substation will allow all four of the existing 230 kV transmission lines between the Redondo Beach substation and La Fresa substation to be de-energized and removed.

Need for additional capacity in the area does not arise until 2021 after the assumed retirement of over 2000 MW of existing OTC generation capacity at the Alamitos generating facility consistent with the SWRCB's OTC unit compliance schedule. Non-conventional generation additions are shown beginning in year 2013. The actual rate at which these resources get added is an important indicator of whether the projected penetration by year 2022 is likely to materialize. If the rate of additions is less than projected, further analysis could be done to evaluate the best course of action in the later years.

Compared to alternatives which rely only on conventional generation to satisfy the Western LA Basin sub-area LCRs, the two alternatives described in the preceding paragraph are environmentally superior. Load reductions and distributed generation additions (including dual purpose CHP) mean a reduction in natural gas consumption and lower air emissions.⁷ In addition, in the absence of SONGS, generation at Huntington Beach is more effective than generation at Redondo Beach in mitigating the overload that establishes LCRs for the Western LA Basin sub-area. Therefore, fewer megawatts of new conventional generation can be added at Huntington Beach than at the Redondo Beach location to satisfy the Western LA Basin sub-area LCRs. The addition of fewer megawatts of new conventional generation will tend to reduce air emission, land use and visual impacts along the Western LA Basin sub-area coastline

Review of the CAISO's LCR analyses later in this paper shows that the CAISO's assumptions regarding load growth (1-in-10 plus 2.5%), mitigation options (no load drop for N-1-1), and likely available resources (such as very low non-conventional generation assumptions and some existing generation assumed off-line) are overly conservative. Using more reasonable assumptions for non-conventional generation it is evident that even without any SONGS generation, there will be plenty of dependable capacity available in the Western LA basin sub-area through year 2022. There will be enough dependable capacity to meet the Western LA

⁷ Load reductions have the ancillary benefit of reducing transmission and distribution losses. Similarly, distributed generation is electrically close to load and therefore also helps to reduce transmission and distribution losses.

basin sub-area LCRs after the retirement of the OTC units, which includes retirement of the existing Redondo Beach generating units.

Tables 1 and 2 and Figures 1 and 2 show the Western LA Basin sub-area LCRs for years 2013 through 2022 under “Without SONGS” and “With SONGS” assumptions. The LCRs are calculated by the CAISO for some years, with other years estimated through interpolation and extrapolation of the CAISO’s estimates. The tables show total dependable capacity (NQC) of existing generation (including plants currently under construction) and remaining generation after the planned retirement of the Once Through Cooling (OTC) units. The tables also show projected uncommitted Energy Efficiency program impacts, non-CHP distributed generation additions, new CHP additions, dispatchable demand response program impacts, and the addition of strategically-located conventional generation additions, where needed. Finally, the tables calculate a nominal local capacity shortage or surplus in the Western LA Basin sub-area.

Comparison of Tables 1 and 2 shows that the LCRs are lower in most years by 500 MW to 1000 MW in the case with SONGS, a significant reduction but much less than the installed capacity of the two SONGS units (2200 MW).

The 2000 MW to 2250 MW of demand reduction and distributed generation in the two alternatives proposed in this paper are intended to be in place by year 2022 and are comprised of: 200 MW of new Combined Heat and Power (CHP), 797 MW of new non-CHP Distributed Generation (DG)⁸, 250 MW of dispatchable demand response (DR), and depending on the status of SONGS, 753 MW to 1000 MW⁹ of currently uncommitted Energy Efficiency (EE) programs. As is described later, these values are assumed to be dependable capacity (Net Qualifying Capacity or “NQC”) and are based on forecasts from State agencies.

The power flow analysis was performed for year 2022 since it has the highest LCR. Power flow analysis confirms that with the dependable capacity assumed to be available in the Western LA Basin sub-area, the CAISO’s projected Western LA Basin sub-area LCR would be met though year 2022 without reliability standard violations.

The power flow analysis shows that the specific locations of load reduction and distributed generation within the Western LA Basin sub-area are important in determining how effective these options are in satisfying the Western LA Basin sub-area LCRs. For purposes of this analysis, the load reductions and distributed generation additions were distributed across the Western LA Basin sub-area, generally in proportion to load levels at each load bus.¹⁰ The results

⁸ In addition to 169 MW of DG assumed for 2022 by the CAISO in its studies.

⁹ The forecast values for uncommitted EE in year 2022 are based on the State agencies’ forecast of 1121 MW in 2021. The analysis conducted for this paper indicates that between 753 MW and 1000 MW of currently uncommitted EE, in combination with other proposed resource additions, is sufficient to meet the Western LA Basin sub-area LCRs.

¹⁰ If the load reductions and distributed generation additions were distributed in a more targeted fashion—focused on the substations with the higher effectiveness factors for the critical overload which establishes the Western LA Basin sub-area LCR—it is possible that there would be no need for any new conventional generation anywhere in the Western LA Basin sub-area.

show that there is no need for generation located at the existing Redondo Beach generating station to meet the LCRs.

Even if forecast distributed generation additions or demand reduction impacts do not happen, the CAISO can use a Remedial Action Scheme to drop load on controlled basis as mitigation for the critical N-1-1 contingency condition. Note that this critical condition only occurs at very high (1-in-10) load levels. Analysis shows that the probability of a critical N-1-1 contingency occurring during a 1-in-10 load event is very remote.

A review of the CAISO's ongoing renewable integration studies reveals that, to date, there is no indication of any need for dispatchable generation at the Redondo Beach site to integrate the anticipated addition of intermittent renewable resources throughout the CAISO Balancing Authority. So far, analyses by the CAISO have not identified a strong locational requirement for the dispatchable resources that are needed to integrate intermittent renewable resources. Within certain broad limits (e.g., northern California versus southern California) dispatchable generation can be located anywhere within the CAISO Balancing Authority.

In addition to confirming that the resource and demand response alternatives proposed in this paper will satisfy the Western LA Basin sub-area LCRs, power flow analysis also confirms that if the Redondo Beach power plant is retired, with or without SONGS generation being on-line, the transmission line reconfiguration at La Fresa substation proposed in this paper will allow the Redondo Beach substation and the four 230 kV lines between Redondo Beach substation and La Fresa substation to be removed without causing any grid reliability issues.

Table 1. Western LA LCR Surplus/(Deficiency) Without SONGS (MW)

Year:	2013	2014	2015	2016	2017	2018	2019	2020	2021	2022
W LA Basin LCR based on CAISO's Category C:	4597*	4664	4731	4797	4864	4931*	4973	5015	5057	5099*
W LA Basin: Effective existing Gen (NQC)**	6364	7345	7345	7345	7345	7345	7345	7345	7345	7345
retire El Segundo OTC unit 3:	0	(335)	(335)	(335)	(335)	(335)	(335)	(335)	(335)	(335)
retire El Segundo OTC unit 4:	0	0	0	(335)	(335)	(335)	(335)	(335)	(335)	(335)
retire Alamitos OTC units 1 - 6:	0	0	0	0	0	0	0	0	(2010)	(2010)
retire Huntington Beach OTC units 1 - 2:	0	0	0	0	0	0	0	0	(452)	(452)
retire Redondo Beach OTC units 5 - 8:	0	0	0	0	0	0	0	0	(1356)	(1356)
Total Retirements	0	(335)	(335)	(670)	(670)	(670)	(670)	(670)	(4488)	(4488)
W LA Basin Gen after OTC retirements (NQC) (MW)	6364	7010	7010	6675	6675	6675	6675	6675	2857	2857
Uncommitted EE within W LA (NQC):	75	151	226	301	377	452	527	603	678^	753
Uncommitted CHP Within W LA (NQC):	20	40	60	80	100	120	140	160	180^	200
Dist Generation within W LA (NQC):	97	193	290	386	483	579	676	772	869&	966
Dispatchable Demand Response (NQC):	25	50	75	100	125	150	175	200#	225	250
1st block of AES's proposed Huntington Beach CC plant:	0	0	0	0	0	0	470	470	470	470
2nd block of AES's proposed Huntington Beach CC plant:	0	0	0	0	0	0	0	470	470	470
Total W LA Basin Expected Gen/Demand Response	6581	7444	7661	7543	7760	7976	8663	9349	5748	5965
LCR Apparent Surplus/(Deficiency)	1984	2780	2930	2745	2895	3045	3690	4334	691	866

The highlighted values are either from CAISO testimony or from other California state agencies. Values for other years are determined through linear interpolation/extrapolation.

* 2013 LCR value is from CAISO's August 20, 2012 "2013 Local Capacity Technical Analysis, Addendum to the Final Report and Study Results, Absence of San Onofre Nuclear Generating Station (SONGS)". 2018 and 2022 LCR values are from CAISO's 2012-2013 Transmission Plan, Table 3.5-7 and Table 3.5-12.

^ Page 21 of D.13-02-015. The power flow analysis confirmed that not all 1247 MW is needed.

Study of Alternative to New Generation at Redondo Beach Plant [June 2013]

& From Table 4 (Environmentally Constrained case) in D.13-02-015. Page 18

Page 56 of D.13-02-015

** The NQC values for year 2013 are from the CAISO's August 20, 2012 "2013 Local Capacity Technical Analysis, Addendum to the Final Report and Study Results, Absence of San Onofre Nuclear Generating Station (SONGS)".

Table 2. Western LA LCR Surplus/(Deficiency) With SONGS (MW)

Year:	2013	2014	2015	2016	2017	2018	2019	2020	2021	2022
W LA Basin LCR based on CAISO's Category C:	5540*	3825*	3922	4018	4115	4211*	4308	4404	4501	4597
W LA Basin: Effective existing Gen (NQC)**	6364	7345	7345	7345	7345	7345	7345	7345	7345	7345
retire El Segundo OTC unit 3:	0	(335)	(335)	(335)	(335)	(335)	(335)	(335)	(335)	(335)
retire El Segundo OTC unit 4:	0	0	0	(335)	(335)	(335)	(335)	(335)	(335)	(335)
retire Alamitos OTC units 1 - 6:	0	0	0	0	0	0	0	0	(2010)	(2010)
retire Huntington Beach OTC units 1 - 2:	0	0	0	0	0	0	0	0	(452)	(452)
retire Redondo Beach OTC units 5 - 8:	0	0	0	0	0	0	0	0	(1356)	(1356)
Total Retirements	0	(335)	(335)	(670)	(670)	(670)	(670)	(670)	(4488)	(4488)
W LA Basin Gen after OTC retirements (NQC) (MW)	6364	7010	7010	6675	6675	6675	6675	6675	2857	2857
Uncommitted EE within W LA (NQC):	100	200	300	400	500	600	700	800	900^	1000
Uncommitted CHP Within W LA (NQC):	20	40	60	80	100	120	140	160	180^	200
Dist Generation within W LA (NQC):	97	193	290	386	483	579	676	772	869&	966
Dispatchable Demand Response (NQC):	25	50	75	100	125	150	175	200#	225	250
Total W LA Basin Expected Gen/Demand Response	6606	7493	7735	7641	7883	8124	8366	8608	5031	5273
LCR Apparent Surplus/(Deficiency)	1066	3668	3813	3623	3768	3913	4058	4204	531	676

The highlighted values are either from CAISO testimony or from other California state agencies. Values for other years are determined through linear interpolation/extrapolation.

*The LCR for year 2013 are from the CAISO's August 20, 2012 "2013 Local Capacity Technical Analysis, Addendum to the Final Report and Study Results, Absence of San Onofre Nuclear Generating Station (SONGS)".

The LCR for year 2014 is from the CAISO's March 28, 2013 "2014 Local Capacity Technical Analysis, Draft Report and Study Results". The LCR for year 2018 is from the CAISO's March 28, 2013 "2018 Local Capacity Technical Analysis, Draft Report and Study Results"

^ Page 21 of D.13-02-015

& From Table 4 (Environmentally Constrained case) in D.13-02-015. Page 18

Page 56 of D.13-02-015

** The NQC values for year 2013 are from the CAISO's August 20, 2012 "2013 Local Capacity Technical Analysis, Addendum to the Final Report and Study Results, Absence of San Onofre Nuclear Generating Station (SONGS)".

Figure 1: Western LA Basin Effective Generation Vs LCR without Songs

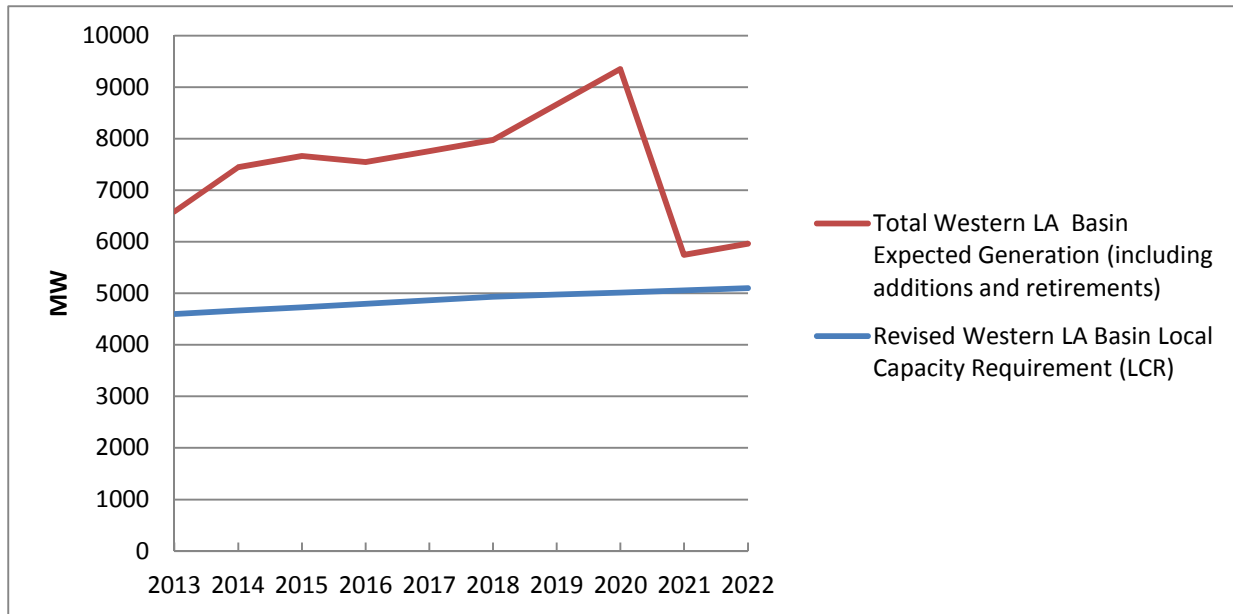
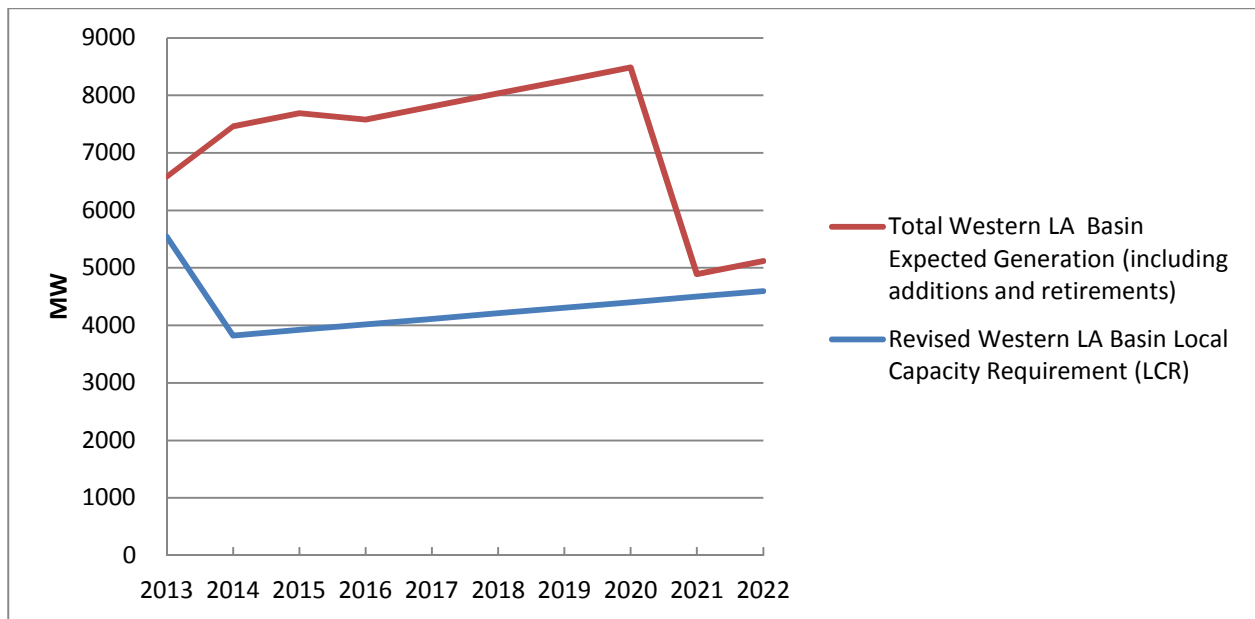

Figure2: Western LA Basin Effective Generation Vs LCR with Songs



Analysis

LCR Analysis

This study examines the Western LA Basin sub-area dependable capacity requirement with and without the availability of generation at SONGS. Comparing the LCRs under with and without SONGS conditions (Tables 1 and 2) reveals (and CAISO data confirms) that SONGS units' unavailability does not have a large impact on the West LA Basin sub-area LCR. This is because according to the CAISO's latest study, the SONGS units' effectiveness in reducing the worst N-1-1 contingency overload is less than 5%. According to CAISO convention, the SONGS units' capacities are not counted toward meeting the Western LA Basin sub-area capacity requirements. Paradoxically, the availability of generation at SONGS does reduce the Western LA Basin sub-area LCRs.

Tables 3.5-7¹¹ and 3.5-12¹² in the CAISO's Board Approved 2012-2013 transmission plan document, provide estimates of the LCRs for the Western LA Basin sub-area for the years 2018 and 2022 assuming either or both SONGS and the Diablo Canyon nuclear power plants units are shut down. The CAISO's August 20, 2012 "*2013 Local Capacity Technical Analysis, Addendum to the Final Report and Study Results, Absence of San Onofre Nuclear Generating Station (SONGS)*" provides the Western LA Basin sub-area LCR for year 2013 with and without SONGS.

The instant report update estimates LCRs for other years during the study horizon by linear interpolation and extrapolation. The data provided on Table 1 of this update shows that LCRs vary between 4600 MW in 2013 and 5099 MW in 2022 with no SONGS units available. Table 2 shows the Western LA Basin sub-area LCRs vary from 5540 MW in 2013 to 4597 MW in 2022 with SONGS generation available,

Probability of the need for the CAISO Calculated Local Capacity Requirements

The CAISO estimates LCRs using a 1-in-10 peak load forecast (there is a 90% probability that actual peak loads will be lower) with an additional 2.5% increase to ensure that even if loads reach the 1-in-10 level, with a 2.5 % margin of security, there will be no voltage instability under contingency conditions.

¹¹ CAISO Board Approved 2012-2013 Transmission Plan document: 2018 Local reliability assessment of LA Basin and San Diego areas. (page 176)

¹² CAISO Board Approved 2012-2013 Transmission Plan document: 2022 Local reliability assessment of LA Basin and San Diego areas. (page193)

The contingency conditions under which the LCRs are estimated assume the worst case overlapping outage of two transmission lines (an N-1-1 contingency condition). This contingency condition has a very small probability of occurrence. Roughly speaking, the outage of one line has less than a 1% (0.01) probability of occurrence. The probability of an overlapping outage of two lines is therefore 0.01% ($0.0001 = 0.01 \times 0.01$). The probability that the foregoing worst case N-1-1 contingency condition will occur during a 1-in-10 peak load condition is several orders of magnitudes smaller and therefore very remote.¹³ While the N-1-1 contingency condition must be studied under reliability standards, the likelihood that this condition will ever occur approaches statistical insignificance.

Conventional Generation Capacity

There are a number of new generators that are under construction in the CAISO Balancing Authority Area (BAA)¹⁴. Some are in the Los Angeles Basin LCR area and are outside the Western LA Basin sub-area, and some are in the Western LA basin sub-area. Any generation additions within the Western LA Basin sub-area also count towards the LCRs for the Los Angeles Basin LCR area.

It is also important to note that the generating capacity values assumed by the CAISO to determine whether there will be sufficient dependable capacity available to meet LCRs are conservatively estimated. The CAISO and CPUC only count NQC values towards LCRs. The CAISO sets NQC values for non-dispatchable generators based on the generators' actual output during historical peak load periods. Accordingly, the NQC values are generally less than these generators' installed capacity, and can be significantly affected by one-time technical anomalies (e.g., the loss of natural gas compression at a gas-fired generating plant) or atypical commercial conditions (e.g., the historical peak load period may have occurred exactly when the need for process heat from a cogeneration plant was at a low level due to the manufacturer's particular

¹³ The probability of an N-1-1 contingency occurring at the peak hour of a 1-in-10 load forecast is $.0001 \times 1 / 8760 = 0.000000001$, which is about 1 in a billion for the peak hour. Because surrounding hours are likely to approach the peak hour load level, there will be more than one very high load level during the ten year period, e.g., 200 hours. Multiplying the single-instance probability by 200 yields a probability of 1 in 5 million.

¹⁴ New conventional generation resources that were modeled in the case, according to the CAISO 2012/2013 Transmission Plan page 220.

- Marsh Landing (760 MW);
- Russell City Energy Center (600 MW);
- Oakley Generating Station (624 MW);
- Lodi Energy Center (280 MW);
- GWF Tracy Combined Cycle (145 MW);
- Los Esteros Combined Cycle (140 MW);
- Mariposa Energy Project (184 MW);
- Walnut Creek Energy Center (500 MW);
- Canyon Power Plant (200 MW);
- NRG El Segundo Repowering Project (570 MW); and
- Sentinel Peaker Project (850 MW).

production schedule). Furthermore, the NQC values used by the CAISO in its 2014 and 2018 Local Capacity Technical Analyses reveal that there are a number of generators in the Western LA Basin sub-area that are assigned a zero megawatt NQC value even though, in previous years, the CAISO has used non-zero NQC values for these generators. Specifically, in the 2014 and 2018 Local Capacity Technical Analyses there are 17 generators assigned a zero megawatt NQC value that in previous years had a combined NQC of 186 MW.¹⁵

It is not the purpose of this paper to take issue with the conditions that the CAISO assumes for purposes of establishing LCRs and the analysis in this report uses the same conservative assumptions. However, decision-makers and consumers should be aware that significant costs are being incurred to prepare for an event which is almost certain to never happen.

Non-Conventional Capacity

Most significantly the CAISO has chosen a very pessimistic and conservative view of the expected development of demand reduction programs (e.g., currently uncommitted energy efficiency) and non-conventional generation resources (e.g., CHP, non-CHP DG, and DR)¹⁶. The CAISO has assumed zero megawatt NQC values in 2022¹⁷ for these resources except for 166 MW (NQC) of D G.

The CAISO's use of overly conservative assumptions is highlighted in the CAISO's testimony in the CPUC's LTPP proceeding. CPUC D.13-02-015 decision quotes a CAISO witness statement as follows:

“...deliberately conservative forecasts must be employed in the assessment of reliability requirements for capacity in constrained areas since the consequences of being marginally short versus marginally long are asymmetric.”¹⁸

The operative public policy question is whether the CAISO has struck the right balance between the costs of being “marginally long” and—considering the very low probabilities involved—the consequences of being “marginally short.” This update report agrees with the CPUC that it is reasonable to assume (i) uncommitted energy efficiency will reduce forecast loads below the level assumed by the CAISO and thereby reduce LCRs below the levels estimated by the CAISO, (ii) some amount of dispatchable demand can be counted towards these lower LCRs, (iii) a modest amount of new CHP will be available to count towards the lower LCRs, (iv) future

¹⁵ Appendix A.

¹⁶ These resources are termed either “incremental” or “uncommitted.” Either term refers to resources beyond the amounts embedded in the CEC's demand forecast.

¹⁷ From an email response from the CAISO planning staff.

¹⁸ Page 22 of CPUC Decision 13-02-015.

non-CHP distributed generation additions will significantly exceed the low levels used in the CAISO's base case analysis.¹⁹

As was mentioned, it is not the purpose of this paper to take issue with the conditions that the CAISO assumes for purposes of establishing LCRs. However, it needs to be understood that the combination of numerous conservative assumptions produces an overly-conservative result; the margin of reliability resulting from the CAISO's analysis is larger than may be apparent at first glance. Nevertheless, except for energy efficiency, demand response, non-CHP distributed generation and CHP, this paper has accepted all the CAISO's load, contingency, and generating resource²⁰ assumptions.

It is the intent of this paper to examine if the use of more reasonable assumptions for the development of preferred resources consistent with the Loading Order in California's Energy Action Plan, would produce a result that is environmentally superior to the construction of new generation at the Redondo Beach facility and that would meet the CAISO's conservative application of reliability standards. The assumed NQC values for preferred resources are taken from estimates provided by the three state agencies (CPUC, CEC and California Air Resources Board) in consultation with the CAISO.²¹

In its estimation of LCRs, the CAISO has, thus far, refused to include any amount of uncommitted energy efficiency in forecast load levels. The CAISO is also unwilling to assume any amount of dispatchable demand can be counted towards estimated LCRs. In addition, while the CAISO does assume that some amount of new distributed generation will get built, its baseline assessment includes the lowest amount of distributed generation among the various renewable resource portfolios provided by the CPUC. The CAISO's baseline assessment includes no new CHP generation additions.

The CPUC's authorization for SCE to procure up to an additional 600 MW of capacity from preferred resources shows the desire of the Commission for use of these resources over fossil-fired generation.

"SCE is also authorized to procure up to an additional 600 MW of capacity from preferred resources and/or energy storage resources. In addition, SCE will continue to obtain resources which can be used in these local reliability areas

¹⁹ The amount of Distributed generation assumed by the CAISO in their case for 2022 according to the CAISO planning staff is 169 MW (NQC).

²⁰ The NQC of existing generation in the Western LA Basin sub-area is obtained from the CAISO's 2013, 2014 and 2018 Local Capacity Technical Analyses reports.

²¹ CPUC D.13-02-015, page 21 "A sensitivity analysis performed at the request of this Commission, the CEC and the California Air Resources Board (CARB), to study a variation on the Environmentally Constrained portfolio. As part of the sensitivity analysis, demand reduction from 1950 MW of uncommitted energy efficiency and 201 MW of additional CHP was included in the model, as provided by the three State agencies and adjusted for the LA basin local area (as part of 2461 MW of uncommitted energy efficiency and 209 MW of uncommitted CHP for the entire SCE territory).³² For the Western LA basis."

through processes defined in energy efficiency, demand response, renewables portfolio standard, energy storage and other relevant dockets.”²²

According to testimony submitted to the CPUC in the LTPP proceeding, most of the interveners, including SCE and the CPUC Division of Ratepayer Advocates (DRA), stated that the CAISO’s assumed values for uncommitted energy efficiency, dispatchable demand response, new non-CHP distributed generation and new CHP resources are too low.

The CPUC staff has developed four renewable generation scenarios for meeting the California’s 33 percent RPS requirement in 2020. These scenarios vary by technology, location, and other characteristics and were developed by considering transmission constraints, cost, commercial interest, environmental concerns, and timing of development. For planning purposes, the CAISO adopted the commercial interest scenario as the CAISO’s baseline case. The CAISO also estimated LCRs using the other three scenarios; the cost-constrained scenario, the environmentally-constrained scenario, and the high distributed generation scenario.

The RPS portfolios cover a broad range of plausible renewable generation possibilities. According to the CAISO:

“The generation resources comprising these four portfolios reflect the latest and best available information on the commercial interests of transmission customers, as measured by interconnection queue positions and whether the resources have signed power purchase agreements with California load-serving entities. Other factors such as cost, procurement policies, permitting, and resource financing capabilities were part of the metrics used to evaluate each portfolio.”²³

According to CAISO testimony in the CPUC LTPP proceeding,²⁴ at the request of the CPUC, the CEC and the California Air Resources Board (CARB), the CAISO performed a sensitivity study using the environmentally constrained RPS portfolio that incorporated uncommitted energy efficiency assumptions and additional CHP. This sensitivity study reduced forecast peak loads in the Western LA Basin sub-area by 1121 MW in year 2021 and modeled 180 MW of new CHP within the Western LA Basin sub-area.

Based on the CAISO testimony in the CPUC’s LTPP proceeding 869 MW (NQC) of Distributed Generation is assumed available in the Western LA basin in the CAISO “Environmentally Constraint” case in 2021.²⁵

²² Page 2, CPUC D.13-02-015.

²³ Page 15, CAISO 2012-2013 Transmission Plan document.

²⁴ Page 21, CPUC D.13-02-015.

²⁵ Page 19 CPUC D.13-02-015

In D.13-02-015 the CPUC found that it is reasonable to assume that 200 MW of dispatchable demand response will be available in the Western LA Basin sub-area by year 2020:

"We will assume a nominal level of 200 MW of dispatchable demand response...by 2020....there appears to be...549 MW of total demand response resources now..."²⁶

SCE's testimony in the CPUC's LTPP proceeding indicated that the total amount of demand response available in the Western LA Basin sub-area is about three times higher:

"SCE witness Silsbee testified that at least 549 MW of demand response is currently available in the Western LA Basin..."²⁷

To determine the amount of the uncommitted energy efficiency, dispatchable demand response, new CHP and new non-CHP distributed generation available in each year of this update's study horizon, linear extrapolation is used.

Load Drop Alternative

In estimating LCRs, the CAISO assumes controlled load drop is not used as mitigation for the N-1-1 contingency condition. However, both CAISO and NERC reliability standards permit the use of controlled load drop for this contingency condition. Were the CAISO to assume the use of some amount of controlled load drop,²⁸ there could be a significant reduction in the LCRs. While controlled load drop imposes some amount of inconvenience for some consumers and is not without cost, the likelihood of actually having to trigger such a load drop scheme is, as discussed above, very remote. It should be noted that an automated load drop scheme is more reliable than a comparable amount of additional generation since load drop activation is subject only to limited amount of software and telecommunication equipment, while the availability of generation is subject to a myriad of electronic and manual control systems, fuel inputs, complex thermal and mechanical systems and emission controls. As far as reliability is concerned, controlled load drop is a more reliable way of reducing the possibility of cascading blackouts or system-wide electric supply failures.

Although, CAISO statements in the CAISO 2018 Local Capacity Technical report indicates that the CAISO allows controlled load drop for N-1-1 contingency conditions, for purposes of estimating LCRs, the CAISO has, for unspecified reasons, chosen not to do so.²⁹

²⁶ Page 56 of D.13-02-015

²⁷ Page 52 of D.13-02-015

²⁸ Controlled load drop would be prearranged so as to avoid dropping critical loads such as hospitals, and sensitive commercial end-uses such as sewage pumping plants.

It is noteworthy that on May 16, 2013 FERC issued a supplemental notice of proposed rulemaking to approve revisions to a mandatory NERC reliability standard (TPL-001) that would allow a transmission planner to shed non-consequential load in response to a single contingency event (N-1).

Other Conventional Generation Alternatives

AES, the current owner of the Huntington Beach generating station, has submitted an Application For Certification (AFC) to the CEC for construction of two combined cycle plants at the location of the existing Huntington Beach generating facility. AES's AFC indicates that the first block of Huntington Beach Project could be on line by the summer of 2019 and the second block by the summer of 2020. While it is uncertain whether AES will be able to secure the required AFC approval from the CEC, and uncertain whether AES will obtain Power Purchase Agreements (PPAs) that provide the financial certainty necessary to proceed with construction, it is clear that generation at the Huntington Beach location is electrically preferred to generation at the Redondo Beach location. The CAISO's Local Capacity Technical Analyses indicate that generation at Huntington Beach is more effective in mitigating the adverse consequences of the worst contingency condition than is generation at Redondo Beach; i.e., generation at Huntington Beach has a much higher "effectiveness factor"³⁰ for the contingency driving the requirements.

Power Flow Analysis

Power flow analyses were performed for year 2022 as it has the highest projected LCR.

Power flow analysis has been recognized by the regulatory agencies as "more sophisticated and precise" than other approaches which attempt to establish compliance with LCRs by simply adding up the amount of generating capacity within a defined area:

*"there is general agreement that the ISO's modeling is more sophisticated and precise. We find the use of the ISO's power flow modeling to be reasonable for these purposes."*³¹

²⁹ "Generally, Category C describes system performance that is expected following the loss of two or more system elements. This loss of two elements is generally expected to happen simultaneously, referred to as N-2. It should be noted that once the "next" element is lost after the first contingency, as discussed above under the Performance Criteria B, N-1-1 scenario, the event is effectively a Category C. As noted above, depending on system design and expected system impacts, the **planned and controlled** interruption of supply to customers (load shedding), the removal from service of certain generators and curtailment of exports may be utilized to maintain grid 'security.' "

³⁰ Page 72 CAISO 2018 LOCAL CAPACITY TECHNICAL ANALYSIS.

³¹ Page 39 CPUC D.13-02-015.

Two separate 2022 power flow cases were obtained from the CAISO secure website to perform the power flow analysis used for the instant study: the 2022 starting case for the LCR analysis³² and a 2022 reliability case for the transmission line reconfiguration/removal study.

Two 470 MW conventional generating units at Huntington Beach³³; along with uncommitted energy efficiency program impacts, dispatchable demand response, new CHP, and new non-CHP distributed generation assumptions included in this update report; have been added to the CAISO's "starting point" power flow case that the CAISO used to develop the 2022 no-nuclear mitigation plan included in the CAISO's 2012-2013 transmission plan report. This modified case was then tested by taking the worst case contingency identified by the CAISO (the outage of the 230 kV Serrano-Lewis #1 line followed by the outage of the 230 kV Serrano-Villa Park #2 line) and verifying that this modified case did not result in any reliability standard violations.

To determine the amount and location of new dependable capacity that is needed to meet the CAISO's estimated Western LA Basin sub-area LCR, different amounts, and locations, of dependable capacity additions were tested in the power flow program by applying the critical contingency condition identified by the CAISO.³⁴ The iterative power flow analysis showed that distributing load reductions (EE and DR) and resources (DG and CHP) across the Western LA Basin sub-area in proportion to load at the various load buses, is not as effective in mitigating the critical contingency-based overload identified by the CAISO as the capacity at a specific bus. That is because the electrical effectiveness of resources in mitigating the critical overload condition depends on the location of the resources relative to the location of the overloaded facility. For the particular contingency described above generation at the location of the existing Huntington Beach power plant -- and to a lesser degree the Alamitos power plant -- are more effective in mitigating the overload than resources distributed throughout the Western LA Basin sub-area.

For the above reason, the amount of unconventional and conventional additions (2000 MW + 940 MW = 2940) MW) to be added in the proposed alternative under the without SONGS scenario is higher than the 2460 MW of conventional generation proposed by the CAISO to be added to satisfy the LCR requirements in 2022.

The result of this iterative process for the without SONGS scenario is the addition of two conventional generating units at Huntington Beach (940 MW of dependable capacity) and a

³² The CAISO refuses to make available to stakeholders the "final" power flow cases which establish the LCR estimates included the CAISO's Local Capacity Technical Analyses and in the CAISO's 2012-2013 transmission plan. This refusal makes it difficult for stakeholders to verify and critique the CAISO's LCR analyses. Moreover it is not apparent what sensitive information resides in the final cases. Assumptions concerning the generation dispatch patterns used by the CAISO, and CAISO assumptions as to assumed resource additions, are just that—assumptions. They are binding on no party and carry only as much, or as little, weight as individual stakeholders choose to give them.

³³ The use of Huntington Beach plant is for convenience. It is conceivable that other electrical locations within the Western LA Basin sub-area would be more or equally effective as the Huntington Beach location for the development of new generation.

³⁴ The CAISO's "starting point" no-SONGS power flow case for year 2022 was used for this purpose.

reduction in the aggregate amount of EE, non-CHP distributed generation, new CHP and dispatchable demand response distributed across the Western LA Basin sub-area (the reduction is from an initial amount of about 2500 MW as estimated by the CPUC and CEC to less than 2000 MW as determined by the instant analysis). Tables 1 and 2 reflect the final dependable capacity additions determined through application of the iterative power flow analysis

The proposed reconfiguration of the transmission lines at La Fresa substation, the removal of the Redondo Beach substation and removal of the transmission lines connecting Redondo Beach substation to the electric network, were studied in the power flow program under with and without SONGS scenarios with all-lines-in-service and contingency conditions assuming high load conditions.³⁵ Specifically, NERC Category A (all lines in-service), Category B (one line out) and Category C (two lines out) conditions in the La Fresa substation area were tested. No overload was observed for the any of the outages studied.

³⁵ The CAISO's with-SONGS and no-SONGS reliability cases for year 2022 were used for this purpose.

Renewable Integration Requirements

Since the release of the original report (in December, 2011) to which this update applies, the CAISO and CPUC have continued to investigate the amount and characteristics of dispatchable generation that will be needed to accommodate the anticipated increase in intermittent renewable generation (mainly wind and solar). Of particular interest is whether, and when, new dispatchable generation will need to be added. This determination depends to some extent on the amount and timing of when existing dispatchable generation, especially generators using Once-Through-Cooling technology, is retired and whether this generation is retooled with air cooling or replaced on-site with new generation.

What is important for the purposes of this update is that, to date, none of this analysis has identified a specific locational requirement that mandates some portion of this dispatchable generation would have to be located at the existing Redondo Beach generating facility. The finding in the original report still stands:

“According to CTPG’s [the California Transmission Planning Group’s] interpretation of the OTC owners’ implementation plans, and based on the likely construction of new generation outside of the existing OTC sites and within the CAISO BA, there will be enough flexible generating capacity added to meet the CAISO’s projected need for 4600 MW of new flexible generation capacity in 2020.”

“From 2013 through 2020 no generation capacity at the Redondo Beach Generating Station location is required to integrate intermittent renewable resources.”

This finding is extended in the instant update to include year 2022. The simple fact is that except for unusual situations where transmission constraints between different regions of the CAISO grid (such as between northern and southern California) limit the ability to move power, dispatchable generation can be ramped up and down anywhere within the CAISO Balancing Authority to offset a rapid decrease or increase in renewable output anywhere in the CAISO Balancing Authority. Given the wide distribution of dispatchable generation throughout the CAISO’s Balancing Authority, and the projected need for dispatchable generation though year 2022, it appears unlikely that any significant locationally-specific dispatchable generation requirements will be found.

Of note, there are several initiatives underway which may either reduce the need for dispatchable generation or which may have the effect of expanding the fleet of dispatchable generation. For example, FERC’s requirement that Balancing Authorities move to 15 minute scheduling will reduce the amount of dispatchable generating capacity that each Balancing Authority needs to have in order to address intra-hour imbalances. Similarly, the Energy Imbalance Market proposals that are being considered in different areas of the WECC, if implemented, will have the effect of combining different Balancing Authorities intra-hour imbalances such that the diversity in the separate imbalances will reduce the combined imbalance. It is likely that most new solar photovoltaic additions will incorporate smart inverter technology. Smart inverters

provide significant voltage control capability, reducing the need for the voltage control provided by synchronous generators.

Finally, dynamic scheduling between Balancing Authorities can significantly increase the pool of dispatchable generation that is available to a Balancing Authority—such as the CAISO’s—that may have significant quantities of intermittent renewable generation. This source of dispatchable generating capacity is likely to become increasingly prominent as significant increases in renewable generation begin to offload existing dispatchable fossil-fired generators. To the extent dispatchable fossil-fired generation output is reduced to accommodate the anticipated increase in renewable generation, an opportunity is created to use this unloaded generating capacity to supply balancing services to those Balancing Authorities with a greater need for such capacity.

Redondo Beach Substation and Associated Transmission Infrastructure

Assuming it is determined that AES's proposal to build new generation at the Redondo Beach is not an environmentally preferred alternative for meeting California's electricity requirements, the existing Redondo Beach generating station will be scheduled for retirement by December 31, 2020. This is the date established by the State Water Resources Control Board for compliance with Once-Through-Cooling requirements. If the existing generating units are retired the need for the transmission facilities connecting the power plant to the electric grid is called into question.

Advanced Energy Solutions has investigated whether it would be feasible from a reliability perspective to remove the existing Redondo Beach 230 kV substation and the four 230 kV transmission lines connecting the substation to the transmission grid. If it is possible to remove these facilities, the entire Redondo Beach site could be restored for beneficial public use.

When the existing generating units are retired the associated step-up transformers can be removed as they would serve no purpose. What remains at the Redondo Beach facility will be the Redondo Beach 230 kV substation. The Redondo Beach 230 kV substation is connected to the transmission grid by four 230 kV transmission lines. The existing connections are shown schematically in Figure 1 below.

Advanced Energy Solutions' investigation found that a relatively simple transmission system reconfiguration at La Fresa substation will allow the existing Redondo Beach 230 kV substation, and all four transmission lines between the existing Redondo Beach 230 kV substation and the existing La Fresa substation, to be removed. The removal of these facilities presents a unique opportunity to restore the entire Redondo Beach power plant site, as well as the existing transmission corridor between the Redondo Beach 230 kV substation and the La Fresa substation, to beneficial public use. Such restoration offers the potential for significant environmental benefits.

The transmission system reconfiguration at La Fresa substation is as follows:

1. Remove the existing 230 kV Redondo Beach-La Fresa #1 and #2 lines, leaving the existing breakers and disconnect switches and two open bay positions at the La Fresa 230 kV bus,
2. Disconnect the existing 230 kV Redondo Beach-Mesa line and the existing 230 kV Redondo Beach-Laguna Bell line within the La Fresa substation perimeter, and
3. Tie the disconnected 230 kV Redondo Beach-Mesa line and the disconnected 230 kV Redondo Beach-Laguna Bell line to the La Fresa 230 kV bus using the two open bay positions that are made available by the removal of the 230 kV Redondo Beach-La Fresa #1 and #2 lines.³⁶

³⁶ It will likely be necessary to redesign the protection scheme around La Fresa substation to reflect the change in system impedances that result from the new system configuration.

When this transmission system reconfiguration is implemented, the existing Redondo Beach 230 kV substation, and all four 230 kV transmission lines between the existing Redondo Beach 230 kV substation and the existing La Fresa substation, can be removed. The resulting transmission configuration is shown schematically in Figure 2 below. Note that this reconfiguration requires virtually no new infrastructure since all four of the existing 230 kV transmission lines that connect the Redondo Beach 230 kV substation to the existing transmission system terminate within, or pass through, the perimeter of the existing La Fresa substation. Further, because there would be no generation at the Redondo Beach site, fault duty on the existing circuit breakers should be reduced thereby obviating any need to replace breakers when the new configuration is implemented.

The reliability of the modified transmission configuration was tested under selected N-1 and N-1-1 contingency conditions using the CAISO's reliability power flow cases for the year 2022 for both with and without SONGS scenarios. The cases include the CAISO's Summer Peak base case assumptions which incorporate the CEC's 1-in-10 year heat wave load forecast plus 2.5% margin, and include forecast transmission system losses and all other CAISO assumptions regarding transmission changes and generation retirements and additions for 2022.

The power flow study showed no reliability standard violations under Category A (all lines in service) conditions, under the selected Category B contingency conditions (one line out) and under selected category C (two lines out) conditions.

Figure 1. Current Redondo Beach Substation Configuration

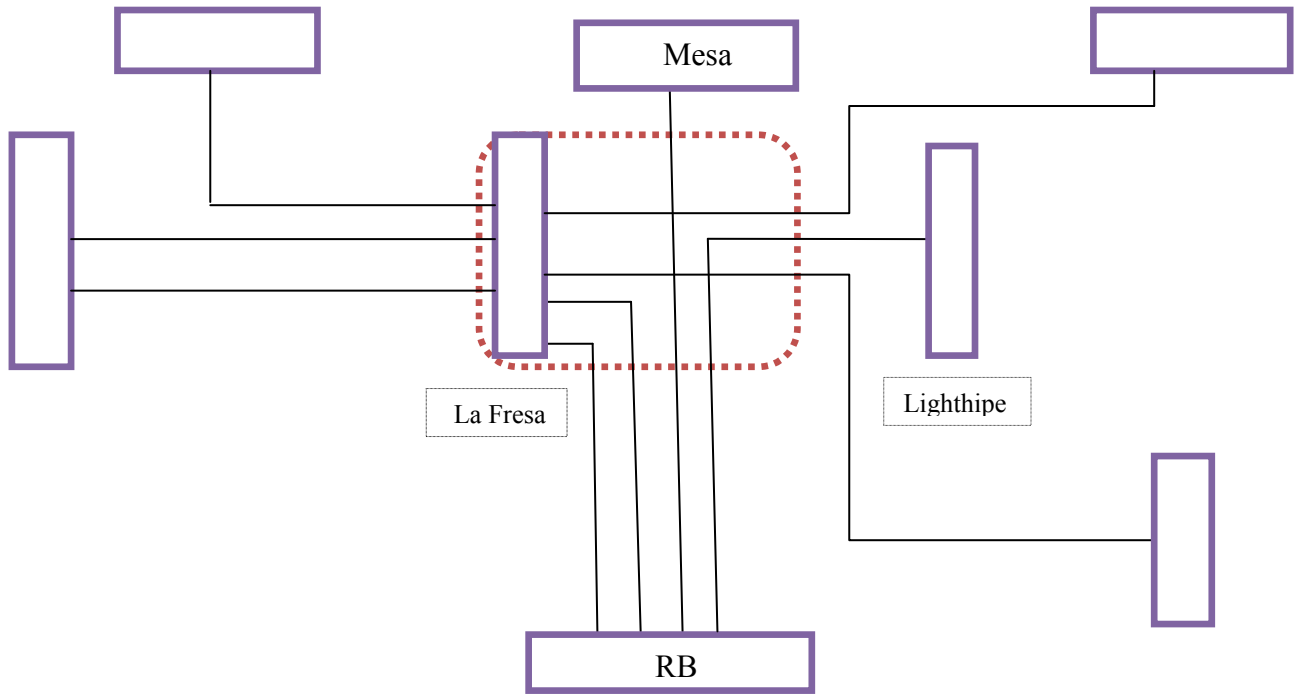
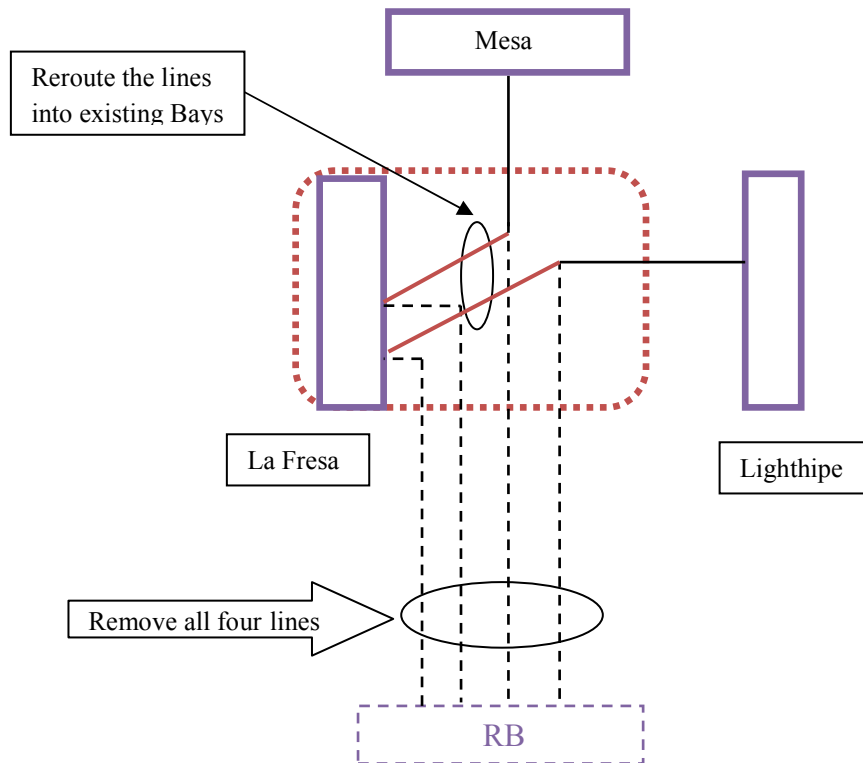

Figure 2. Redondo Beach sub removed and Modified La Fresa 230 kV Substation



Appendix A

Generator Name	2013/2014 Report (NQC - MW)			Initial Report (NQC - MW)
BARRE_2_QF	0		Western Western, El	QF/Selfgen
CHEVMN_2_UNITS	0	1	Nido Western, El	QF/Selfgen 1.58
CHEVMN_2_UNITS	0	2	Nido	QF/Selfgen 1.61
CHINO_2_SOLAR	0		Western	Market
ELLIS_2_QF	0		Western, Ellis	QF/Selfgen 0.29
JOHANN_6_QFA1	0		Western, Ellis	QF/Selfgen
RHONDO_6_PUENTE	0		Western	Market 4.00
VILLPK_6_MWDYOR	0		Western	MUNI 3.90
ARCOGN_2_UNITS	0	1	Western	Market 35.00
HINSON_6_QF	0	1	Western	QF/Selfgen
NA ORCOGEN	0	1	Western, Ellis Western, El	QF/Selfgen 12.00
NA OUTFALL1	0	1	Nido Western, El	QF/Selfgen 17.00
NA OUTFALL2	0	1	Nido	QF/Selfgen 17.00
NA COYGEN	0	1	Western, Ellis	QF/Selfgen 20.00
NA FEDGEN	0	1	Western	QF/Selfgen 24.70
NA HILLGEN	0		Western	QF/Selfgen
NA THUMSGEN	0		Western	QF/Selfgen 49.00
	0			subtotal: 186.08