



**Sacramento  
Cogeneration  
Authority**

P.O. Box 15830, Sacramento, CA 95852-1830 • 916/732-5218

Procter & Gamble Cogeneration Project

SCA 93-076

December 22, 1993

Mr. B. B. Blevins  
California Energy Commission  
Attn: Dockets Unit  
1516 Ninth Street  
Sacramento, CA 95814

**DOCKET  
93-AFC-2**

DATE: DEC 22 1993  
RECD: DEC 23 1993

**COPIES OF RESPONSES TO INFORMATION REQUESTED BY CEC STAFF FOR THE  
PROCTER AND GAMBLE COGENERATION PROJECT (DOCKET NO. 93-AFC-02)**

Dear Mr. Blevins:

Please find enclosed 12 copies of the information requested by the CEC staff for the proposed Procter and Gamble Cogeneration Project. Included are the following:

- legible copies of figures 3.15-7, 8, and 9;
- names and telephone numbers of agency personnel, identification of the source for Section 6's discussion of City areas experiencing renewal, and a clarification of what information figure 6.6-3 is intended to convey;
- numbering/citing of references within the transportation text, clarification of a discrepancy regarding traffic numbers on figure 6.5-4, and a discussion of actual traffic numbers and volume-to-capacity ratios in relation to LOS during construction;
- amended table 3.6-1 to include seismic design coefficients and typical plans, elevations, and sections for the cooling tower and elevated deaerator support structure. Please note that the elevator deaerator support structure will be designed as a building framed system in accordance with UBC Section 2.3.3.3 paragraph F.

If you have any questions regarding this information, please contact Diana Parker (732-6540).

Sincerely,

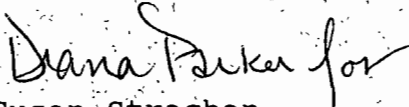
  
Susan Strachan  
Manager, Licensing & Permitting

Enclosures

cc: Ron Sims, Walsh  
Rich Chapman, Black & Veatch

STATE OF CALIFORNIA

State Resources Conservation  
and Development Commission

In the matter of:	)	Docket No. 93-AFC-2
	)	
Application for Certification	)	PROOF OF SERVICE
of the Sacramento Cogeneration	)	(rev. 12/3/93)
Authority's Procter & Gamble	)	
Cogeneration Project	)	
_____	)	

PROOF OF SERVICE

I, Diana Parker, declare that on December 23, 1993, I deposited copies of the attached Letter to Mr. B. B. Blevins, CEC, Re: Responses To Information Requested By CEC Staff For The Procter & Gamble Cogeneration Project (Docket No. 93-AFC-02) in the United States mail at Sacramento, California, with first class postage thereon fully prepaid and addressed to the following:

APPLICANT

Ms. Susan Strachan, Manager  
Projects Permitting & Licensing  
SMUD  
Box 15830  
Sacramento, CA 95852-1830

Steve Cohn  
Senior Attorney  
SMUD  
P.O. Box 15830  
Sacramento, CA 95852-1830

INTERESTED AGENCIES

Richard Johnson  
Division Chief  
Sacramento Metro AQMD  
8411 Jackson Road  
Sacramento, CA 95826

Ray Menebroker, Chief Project  
Assessment Branch  
Stationary Source Division  
California Air Resources Board  
P. O. Box 2815  
Sacramento, CA 95814

Ed Schnabel  
Sacramento Metropolitan Water District  
5331 Walnut Avenue  
Sacramento, CA 95841

CALIFORNIA ENERGY COMMISSION  
(Docket Unit - 12 copies required)

Docket Unit, MS-4  
1516 Ninth Street  
Sacramento, CA 95814

I declare under penalty of perjury that the foregoing is true and correct.

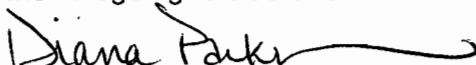
  
\_\_\_\_\_  
Signature

# SMUD TRANSMISSION SYSTEM

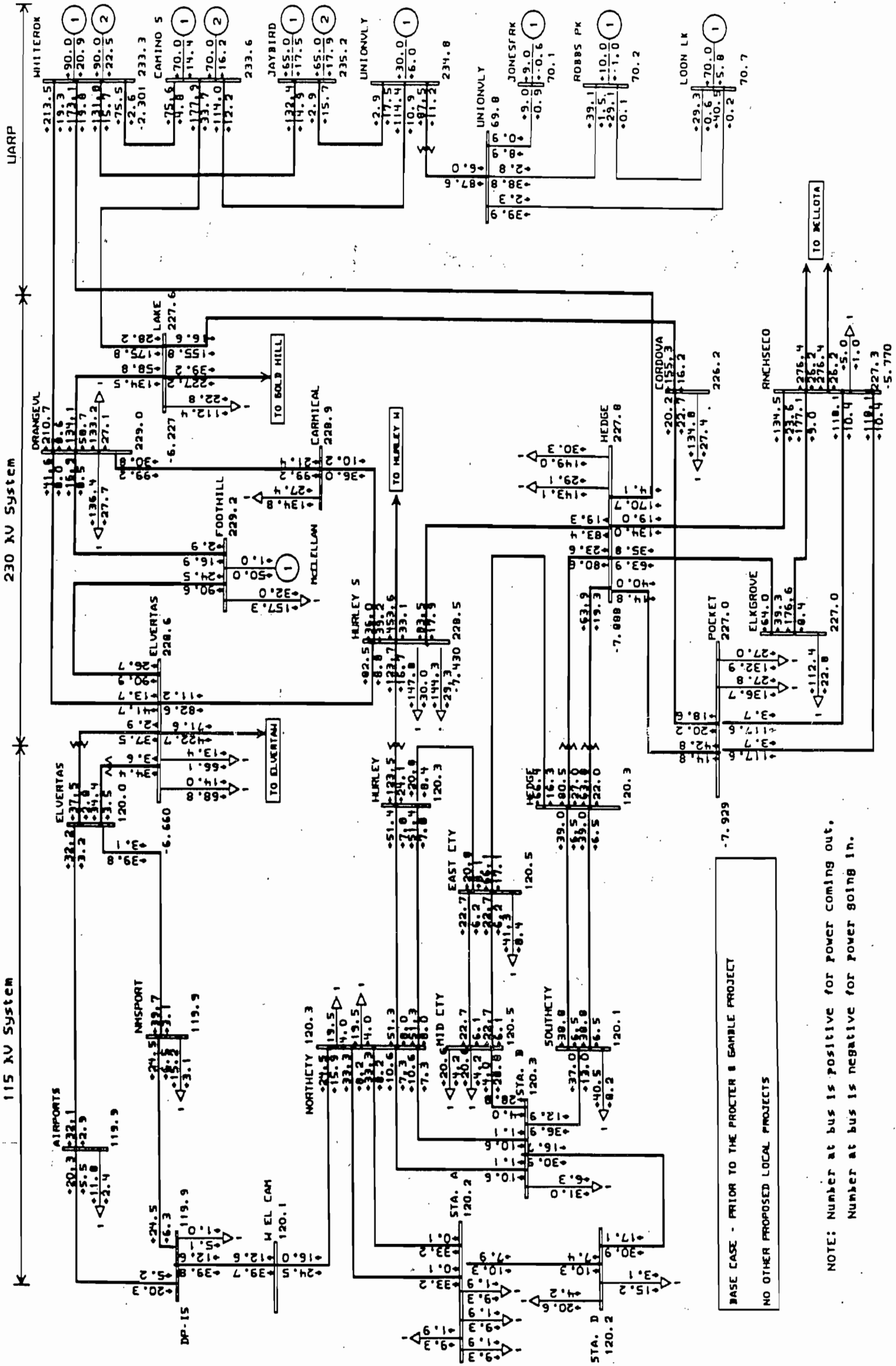

BASE CASE - PRIOR TO THE PROCTER & GAMBLE PROJECT  
NO OTHER PROPOSED LOCAL PROJECTS

NOTE: Number at bus is positive for power coming out,  
Number at bus is negative for power going in.

Electric Power Consultants Inc. PS&F Program  
1996 H52 H5CC + PG&E DETAIL + SMUD DETAIL  
BASE CASE - NO PROCTER & GAMBLE PROJECT  
CAPTION FOR OTHER PROJECTS AND RENDERING NOT ON-LINE



SMUD Transmission System  
With No Project Generation  
Figure 3.15-7

Thu Feb 11 16:26:07 1993  
PFCBSWO.DRW  
PFCBSWO.SAV

# SMUD TRANSMISSION SYSTEM

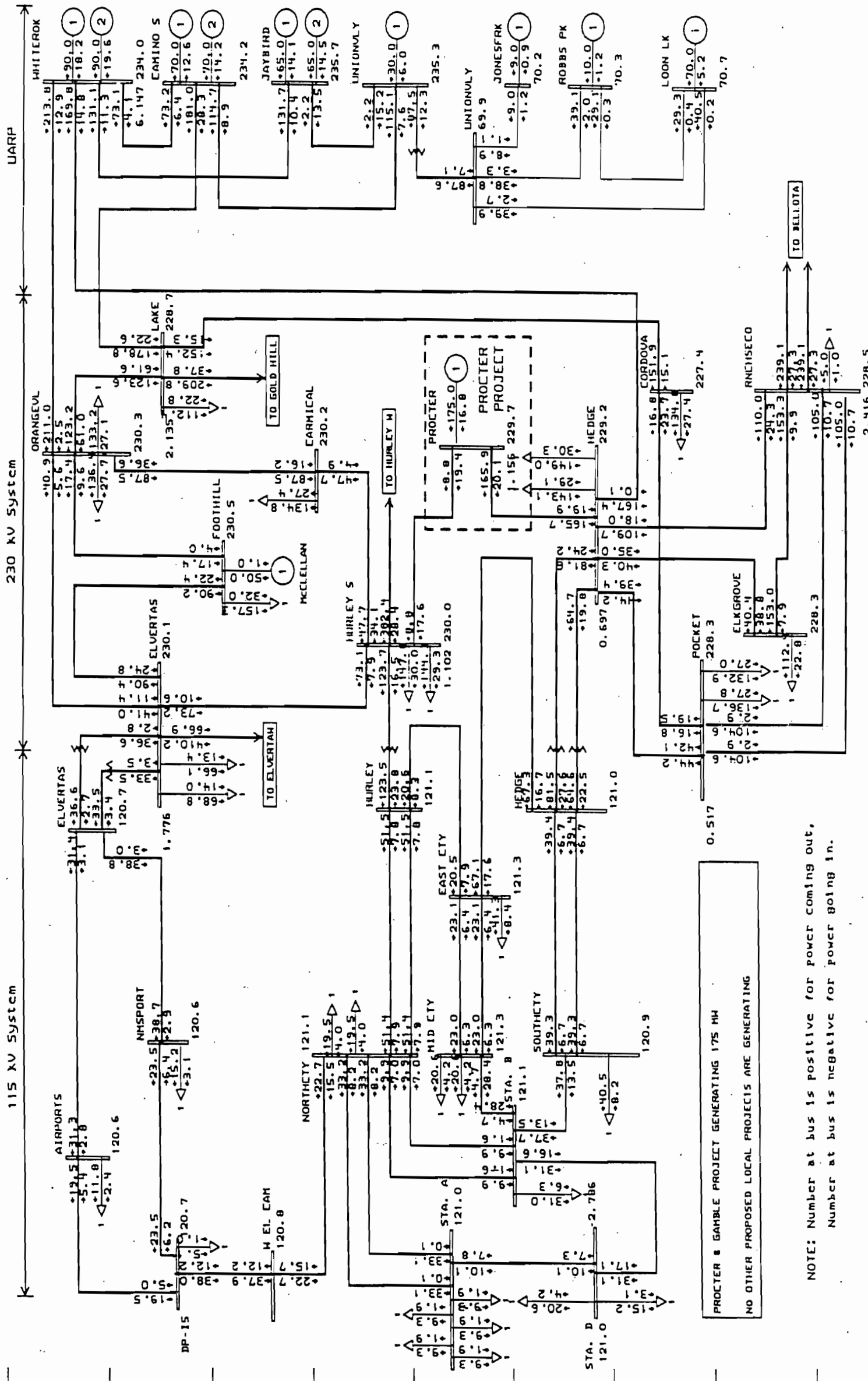

PROCTER & GAMBLE PROJECT GENERATING 175 MW  
NO OTHER PROPOSED LOCAL PROJECTS ARE GENERATING

NOTE: Number at bus is positive for power coming out,  
Number at bus is negative for power being in.

SMUD Transmission System  
With Project Generating 177 MW  
Figure 3.15-8

092793-2

3-70

# SMUD TRANSMISSION SYSTEM

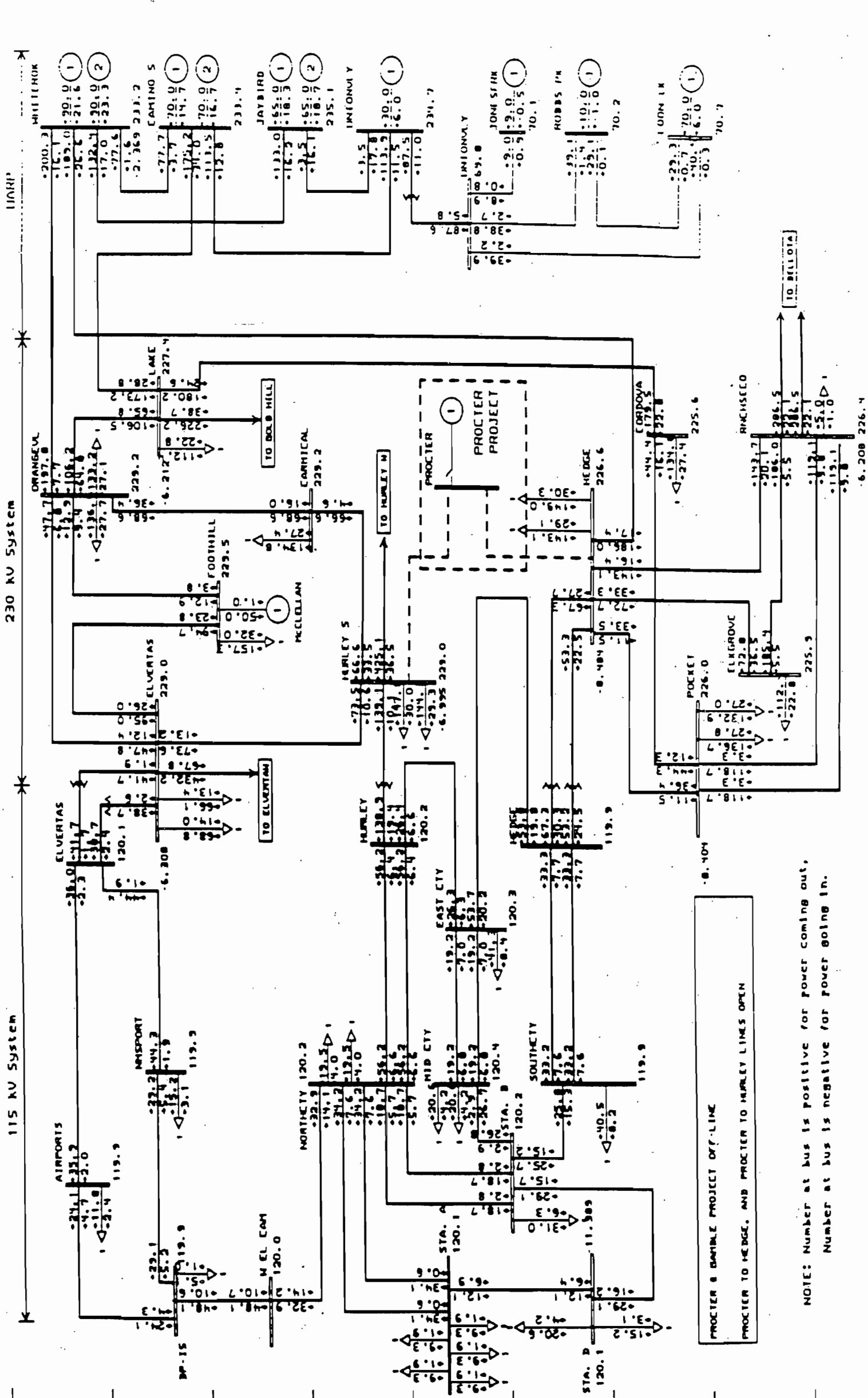

NOTE: Number at bus is positive for power coming out,  
 Number at bus is negative for power going in.

PROCTER & GAMBLE PROJECT OFF-LINE  
 PROCTER TO HEDGE, AND PROCTER TO HURLEY LINES OPEN

Electric Power Consultants, Inc. PS&E Program  
 1996 IIS2 WSCC - PG&E DETAIL - SMUD DETAIL  
 PROCTER & GAMBLE PROJECT OFF-LINE  
 PROCTER TO HEDGE & PROCTER TO HURLEY 230 KV LINES OPEN

SMUD

105 Feb 16 11:20:58 1999  
 FROM OFF. DRW  
 FROM OFF. 369

SMUD Transmission System  
 During Construction of Project Interconnection  
 Figure 3.15-9

**LAND USE**

*Questions discussed during telephone conference call.*

**SCA RESPONSE:**

Three questions were posed by the CEC during the telephone conference call on November 15, 1993. Participants in the conference call included Jeff Evans (CEC), Diana Parker (SMUD), David Lefebvre (B&V), Doug Timpe (B&V), and Robin Goldman (B&V).

Question 1: Names and phone numbers of agency personnel contacted for information during work on the AFC.

Response: Sandra Yope - City of Sacramento Planning & Development (CSPD). (916) 264-5604. Called for information regarding zoning maps. 4/30/93.

Gary Atchley - CSPD. (916) 264-7027. Called regarding the discing of vacant lots within the City of Sacramento limits. 8/27/93.

Mark Kraft - CSPD 264-7064. Consultations regarding potential future land uses on the US Army Depot site.

Mike Dale - CSPD. (916) 264-5318. Consultations regarding the possible need for a Special Use Permit.

Benita Dobbs - McClellan Air Force Base. (916) 643-2111. Called regarding the official status of McClellan Air Force Base. 6/29/93.

Ernie Kowalski - Mather Air Force Base. (916) 364-2908. Called to get the official closure status of Mather Air Force Base. 6/29/93.

Roy Imai - County of Sacramento Parks & Recreation. (916) 366-2072. Called to get general information regarding the adequacy of parks and recreational facilities within the County. 6/15/93.

Michelle Rudek - City of Sacramento Parks & Recreation. (916) 264-7634. Called to get general information regarding the adequacy of parks and recreational facilities within the City. 6/15/93.

Jo Wray - Sacramento Area Council of Government. (916) 457-2264. Called to verify the primary functions of SACOG within its jurisdiction. 8/3/93.

Doug Holmen - CSPD. (916) 264-5381. Consultations regarding uses of the US Army Depot site following closure.

Rosemary Pierce - CSPD. (916) 264-5604. Called to get information about community plans. 4/20/93.

Bob Wilson - Sierra Nevada Airway Facilities Sector. (916) 551-3286. Called to determine whether any ground navigational aids or active radar exists near the proposed transmission line corridor. 5/31/93.

Question 2: Identify source of Section 6.0 discussion of areas that are experiencing renewal.

Response: The source for Section 6's discussion of areas of the City that are experiencing renewal is Sacramento Today, 1992/1993, pg. 45, published by the Sacramento Metropolitan Chamber of Commerce and Sacramento Association of Realtors. A xerox copy of the title page and page 45 is enclosed.

Question 3: Verify that Figure 6.6-3 contains information depicting

existing land use.

Response: Figure 6.6-3, titled "Existing Land Use in the Project Vicinity," does depict existing land use. Figure 6.6-12, "Specific Land Use Plan Designations in the Project Vicinity," shows planned (combined existing and future) land uses.

In a telephone call to Mark Kraft of the City of Sacramento Planning and Development Department, it was determined that Figure 6.6-3 depicts existing land use as well as reasonably possible. Attached is the telephone memo detailing the conversation.

## BLACK &amp; VEATCH

## TELEPHONE MEMORANDUM

Sacramento Cogeneration Authority  
Procter & Gamble  
Status of the County of Sacramento Revised  
Draft of the General Plan

B&V Project 23933  
B&V File 32.0405.01A  
December 7, 1993  
11:00 a.m.

To: Mike Winter  
Company: County of Sacramento Planning & Development  
Phone No.: (916) 440-6221

Recorded by: Robin Goldman *RRG*

I called Mike to request information regarding the status of the County of Sacramento Revised Draft of the General Plan (Plan). I briefly outlined the project specifics applicable to land use with Mike to familiarize him. I explained that some adequacy comments have been received from the CEC. One of the comments concerning land use states:

6.6-14, Section 6.6.2 includes a discussion of relevant Sacramento General Plan policies. However, this section discusses only proposed sections of the draft General Plan. Because of the uncertainty that the draft General Plan will be approved prior to the decision on the AFC, please provide a similarly detailed review of the existing General Plan and affiliated community plans. Please address all relevant policies, objectives, and goals and discuss to what extent the proposed policy complies with the proposed policy complies with them.

Mike said the Plan is scheduled to be formally adopted by the Sacramento County Board of Supervisors (Board) either tomorrow (December 8) or next Wednesday (December 15). According to Mike, the review and commenting period is complete; the Board simply needs to sign the resolution and formally adopt the Plan.

I expressed my reservation to order the currently existing General Plan and analyze the project's compliance since the Revised Draft is scheduled to be adopted so soon. Mike agreed that it would be a wasted effort to show compliance with the existing General Plan. First of all, the current Plan is out dated and is not as inclusive as the Revised Draft Plan. Secondly, by the time the analysis has been written and revised by B&V and SMUD and finally submitted to the CEC, the Revised Draft will be approved.

Mike asked who I was working with at the CEC. I told him Jeff Evans is the person handling land use issues for this project at the CEC. Mike said that he used to work with Jeff. In addition, Mike told me that if there were any further concerns regarding this particular adequacy question, he is willing to talk to Jeff about the justifications of his



BLACK & VEATCH

TELEPHONE MEMORANDUM

Page 2

Sacramento Cogeneration Authority  
Procter & Gamble  
Status of the County of Sacramento Revised  
Draft of the General Plan

B&V Project 23933  
December 7, 1993

recommendation.

Finally, Mike asked if the date on my copy of the Revised Plan is December 9, 1992. When I told him it was, Mike said that the Plan I have is fairly comprehensive. Some minor changes have been made to the text in certain Elements of the Plan since December, 1992. However, those changes will not be available to the public until a couple of weeks after the Plan has been adopted by the Board.

I thanked Mike for his help and insight and indicated that I would be contacting him again next week to check on the status of Plan adoption and availability of changes to the Revised Draft.

BLACK & VEATCH

TELEPHONE MEMORANDUM

Sacramento Cogeneration Authority  
Procter & Gamble  
CEC Land Use Adequacy Questions

B&V Project 23933  
B&V File 32.0405.01A  
December 13, 1993  
10:00 a.m.

To: Mark Kraft  
Company: City of Sacramento Planning & Development  
Phone No.: (916) 264-8116

Recorded by: Robin Goldman *RRG*

I explained to Mark that I had received comments and data adequacy requests from Jeff Evans of the CEC regarding land use. One of the questions was posed during a telephone conference call on November 15th. Jeff wanted to know whether Figure 6.6-3, "Existing Land Use in the Project Vicinity" depicts future or existing land use.

I explained to Mark that I had used the County's Land Use Diagram to determine existing land used in the project vicinity. Mark said that the County of Sacramento does not keep records or maps of existing land use. In order to construct a map precisely depicting exact, current land use, a windshield survey combined with zoning maps would be the best way to accurately show existing land use. The drawback to this approach is that it would be extremely time consuming and very costly.

Mark said the problem with using the Land Use Diagram is that there are places where it depicts a certain land use when, in fact, another usage exists (e.g. a few houses in an area designated for industry). I told Mark that the map scale is 1:24,000 at the CEC's request and a few discrepancies will not show on a map of that scale. Zoning maps as a guide for land use were discussed but it was agreed that zoning maps are likely to be even less accurate for existing land use.

Mark said that given the circumstances, usage of the County's Land Use Diagram was the most accurate way available to document existing land use in the County of Sacramento.

1 9 9 2 / 9 3

# Sacramento REGION Today

## THE COMPLETE GUIDE TO CALIFORNIA'S CAPITAL

- BUSINESS
- NEIGHBORHOODS
- RECREATION
- LIFESTYLES
- HOUSING
- SERVICES

The Official Publication  
of the Sacramento  
Metropolitan Chamber  
of Commerce and the  
Sacramento Association  
of Realtors

proper potluck to welcome a new neighbor.

Oak Park, one of Sacramento's first prestigious suburbs, fell on hard times after World War II. "Oak Park is another area in transition," says Swayne. City redevelopment dollars — and the high-priced housing market of the late '80s — are provoking a steady recovery of this neighborhood, he says.

The University of California, Davis, Medical Center and the University of the Pacific's McGeorge School of Law have greatly influenced the area. Another strong force in the community is *The Sacramento Observer*, a tabloid newspaper serving Sacramento's black community.

**Area 6: Rancho Cordova, College Greens, Rosemont** Rancho Cordova is largely residential, although business and industrial parks are increasingly providing homes for corporations. Rancho runs along the south bank of the American River between the Arden Bar bend of the river and Sunrise Boulevard. A high availability of apartments and ranch-style homes is standard.

The quality of Rancho Cordova's subdivisions varies primarily due to economic levels and the density of rentals, says Steve Timberlake, a Realtor® with Coldwell Banker. An emerging new attitude is resulting in physical changes such as repaving and beautification of Folsom Boulevard, the area's main street. Organized business and residents' groups are dedicated to preserving the best of the community's spirit while it moves forward with the changing growth of the area.

College Greens is also located on the south bank of the American River. It is a quiet, residential community of young families. Homes and lawns are neat and trim with lower price tags than some of the surrounding neighborhoods. Trips to California State University, Sacramento, or to downtown are easy, and Highway 50 runs along its southern boundary.

Rosemont residents have forged their own identity, considering themselves quite separate from Sacramento or nearby Rancho Cordova, although the neighborhood has a Sacramento mailing address and its schools are in the Sacramento City Unified School District. On the other hand, Rosemont is a part of the Rancho Cordova Recreation and Park District. Some residents see the dichotomy as the best of both worlds.

A suburban area with moderately priced housing and a selection of apartments, Rosemont lies between Folsom Boulevard/U.S. 50 and Jackson Road, from Watt Avenue to Bradshaw Road. It's a popular community for retirees from nearby Mather Air Force Base.

**Area 7: Arden/Arcade, Campus Commons** The Arden/Arcade community promises something for every home buyer. Do-it-yourselfers will uncover bargain-priced fix-or-uppers, while the executive set can select from sprawling estates located in Wilhaggin, Sierra Oaks and Arden Oaks.

Arden/Arcade encompasses Arden Park,

**AREA 4: VITAL STATISTICS**

**Schools**

Sacramento City Unified School District ..... 553-4300  
Elk Grove Unified School District ..... 686-5085

**Transportation**

Regional Transit bus lines

**Health Care**

served by Kaiser Permanente South ..... 688-2000  
Methodist Hospital ..... 423-3000

**Parks and Recreation**

**Highlights**

Florin Creek Biking and Hiking Trail  
Valley HI Park  
Freeport Park

**Governmental Districts**

7th and 8th City Council districts, 2nd supervisorial, 8th, 9th and 10th state Assembly, 5th and 6th state Senate and 5th Congressional

**Libraries**

Southgate Community Library ..... 421-6327  
Martin Luther King Jr. Regional Library ..... 421-3151

**AREA 5: VITAL STATISTICS**

**Schools**

Sacramento City Unified School District ..... 553-4300  
University of the Pacific's McGeorge School of Law ..... 739-7191

**Transportation**

Regional Transit buses and Metro light rail

**Health Care**

UC Davis Medical Center

**Parks and Recreation**

**Highlights**

Tahoe Park, features a swimming pool and horseshoe pits  
Colonial Park  
McClatchy Park and Oak Park offer summer music concerts  
Curtis Park

**Governmental Districts**

5th and 6th City Council, 1st and 2nd supervisorial, 9th state Assembly, 6th state Senate, 5th Congressional

**Library**

Colonial Heights Library ..... 455-2985

**AREA 6: VITAL STATISTICS**

**Schools**

Folsom Cordova Unified School District ..... 985-4483  
San Juan Unified School District ..... 971-7700  
Sacramento City Unified School District ..... 553-4300

**Transportation**

Greyhound, Metro light rail and Regional Transit buses

**Health Care**

nearest are Mercy San Juan 537-5000 or Mercy American River Hospital ..... 484-2222  
Kaiser Permanente South ..... 688-2000

**Park and Recreation Highlights**

Hagan Community Park, includes a petting zoo and swimming pools  
Lincoln Village Park, features swimming pools and picnic areas  
Cordova Community Park  
Cordova Golf Course, a full 18-hole  
C.M. Goslin Park within the American River Parkway

**Governmental Districts**

6th City Council, 5th supervisorial, 10th state Assembly, 5th state Senate, 11th Congressional

**Library**

Rancho Cordova Community Library ..... 362-0641

**AREA 7: VITAL STATISTICS**

**Schools**

CSU, Sacramento ..... 278-4636  
San Juan Unified School District ..... 971-7700

**Transportation**

Metro light rail, Regional Transit buses

**Health Care**

nearby are Sutter Memorial 454-3333  
Mercy General ..... 453-4545  
Kaiser Medical Center ..... 973-5000  
Mercy American River ..... 484-2222

**Parks and Recreation**

**Highlights**

American River Parkway with bike and equestrian trail  
William Pond Park  
Howe Community Park with ball fields

**Governmental Districts**

3rd and 6th City Council, 3rd supervisorial, 10th state Assembly, 5th state Senate, 5th Congressional

**Libraries**

Arcade Community Library ..... 483-5061  
Arden Library ..... 483-6361

**PROCTER & GAMBLE COGENERATION PROJECT  
SACRAMENTO COGENERATION AUTHORITY**

**RESPONSES TO CEC DATA REQUESTS  
(Set 1, dated December 3, 1993)**

**TRANSPORTATION (Additional Items)**

*Item 1*

*Numbering/Citing of references (example - SACOG, several references in bibliography with same date, it is not clear to which the text is referring.)*

**SCA RESPONSE:**

Attachment TRANS-1 includes pages of text from the AFC in which references were cited. The numbers in the page margins correspond to the numbered references included in Subsection 6.5.8 (References). References to additional documents which support the transportation discussion have been added to Subsection 6.5.8 and are indicated by change bars in the margins.

*Item 2*

*Discrepancy between traffic numbers on Figure 6.5-4 and text in last paragraph on page 6.5-14 (22,250 vs 23,250.)*

**SCA RESPONSE:**

The correct number is 23,150 as listed on page 6.5-14.

*Item 3*

*Discussion of actual traffic numbers and volume-to-capacity ratios in relation to LOS during construction.*

**SCA RESPONSE:**

The numbers used to evaluate the LOS during construction are equal to the 1993 traffic volumes provided in Appendix I of the AFC escalated to May 1996 at a 3.3 percent rate (refer to page 6.5-26 of the AFC). These traffic numbers are a component of the volume-to-capacity (v/c) ratio and the volume-to-capacity ratio is one variable which impacts the calculation of the LOS in the traffic model.

The relation between LOS and the volume-to-capacity ratio is not always direct. LOS is defined in terms of the average delay per vehicle and the v/c ratio is one of many factors which influences average delay. However, the v/c ratio may not always be reflective of the LOS and to rely exclusively on the v/c ratio as an indication of LOS may not be accurate. To illustrate using the Folsom/Power Inn intersection, the a.m. v/c ratios by lane group for each approach and the calculated delay and LOS for each approach are shown in Table 1. For eastbound traffic, the v/c ratio for each lane group (left turn, through, and right turn) is below 0.5, a generally favorable condition, yet the calculated average delay per vehicle is 27.1 seconds, a LOS of D. In this example, factors in addition to the v/c ratio (such as the duration of signal phasings and progression through the intersection) have an important impact on LOS.

One implication from the influence of many factors on the LOS is that where the LOS is unacceptable, there may be ways to improve the LOS other than reducing traffic levels. Pages 9-4 and 9-5 of the TRB's Highway Capacity Manual, Special Report 209 are attached and these pages describe the relation of the v/c ratio to LOS in more detail.

Although the Highway Capacity Manual, Special Report 209 discourages the use of v/c ratios as a proxy for LOS, it is common to see "rule-of-thumb" estimates equating v/c ratios to LOS. The basis for these estimates is often the TRB's Circular 212 model (no longer issued by TRB), which was the predecessor of the TRB Model 209 used in this analysis. Circular 212 defined the LOS for a signalized intersection in terms of the v/c ratio. These ratios were: LOS A = v/c ratio 0.60 or lower, LOS B = v/c ratio of 0.61-0.70, LOS C = v/c ratio of 0.71 - 0.80, LOS D = v/c ratio of 0.81-0.90, LOS E = v/c ratio of 0.91 - 1.00 and LOS F = v/c ratio of 1.00 or higher. The problems of equating these v/c ratios with the LOS are evident in Table 1 and the attached pages.

Table 1. Comparison of V/C Ratios and LOS for Power Inn Rd. and Folsom Blvd.

Approach	Lane Group	V/C Ratio	Approach Delay	Approach LOS
Eastbound	L	0.464	27.1	D
	T	0.250		
	R	0.073		
Westbound	L	0.491	21.5	C
	T	0.483		
	R	0.231		
Northbound	L	0.379	29.6	D
	T	0.677		
	R	0.096		
Southbound	L	0.584	44.5	E
	T	1.013		
	R	0.041		

**Attachment Trans -1**  
**TRANSPORTATION REFERENCES**



## 6.5 Transportation

The Greater Sacramento Area has an extensive transportation network. Interstate freeways, continental railways, a deep-water shipping channel, and a major airport give the Greater Sacramento Area easy access to many major markets. These transportation systems are discussed in this section.

### 6.5.1 Existing Transportation Network and Conditions

This section describes the existing transportation network and conditions in the Sacramento region and also describes the network in place near the project site. The emphasis is placed on the highway network, given the project's potential for impacts on this mode of transportation.

**6.5.1.1 Regional Roadways and Traffic.** The Sacramento region has a well developed network of state, federal, and local highways. Table 6.5-1 indicates that in Sacramento County alone, there was a total of 4,006 miles of public roads in 1989. In the four Sacramento metropolitan statistical area (MSA) counties of El Dorado, Placer, Sacramento, and Yolo, the total mileage of maintained roads was 9,258 miles in 1989, or 5.63 percent of the 1989 state total.

Four major highways traverse the Sacramento region and allow quick access to other California locations and beyond. Figure 6.5-1 is a regional transportation map indicating the major highways in the Sacramento region.

Major highways include Interstate 80, Highway 50, Interstate 5, and Highway 99. Use of these highways by local and regional traffic has resulted in high levels of traffic volume as measured by the average daily traffic (ADT) counts. For example, within Sacramento County, Highway 80 has a 174,000 ADT on its most heavily traveled segment, which is between the junction of Route 244 and the Madison Avenue interchange (Caltrans 1992). Highway 50 has a maximum ADT of 193,000 (at the 15th and 16th Street interchange); Highway 99 has a maximum ADT of 161,600 (at the north junction with Highway 50); and Highway 5 has a 114,000 ADT at the I Street interchange (Caltrans 1992). All figures are 1991 ADT counts.

The high levels of traffic volume over the region's roadway network has resulted in congestion in several areas during periods of peak use, and the problems are expected to intensify in the future. By the year 2000, each of the four major highways through Sacramento is projected to be at or near its rated vehicle volume capacity near downtown Sacramento (SACOG 1990) as shown in Table 6.5-2. In addition to these highways, segments of Route 160, Route 51, and Route 16 in Sacramento County are projected to reach peak hour capacity levels by 2000.

**6.5.1.1.1 Adverse public safety impacts.** Generally, the multilane design of the highways and primary roads in the vicinity of the project is conducive to public safety. Nevertheless, the high volume of traffic carried by these roadways during peak hours may be considered a safety hazard. This is especially true on Highway 99 and Highway 50 where stop and go traffic or traffic flow significantly below the speed limit is common.

14 Another feature of the local roadway network that could affect public safety is the light rail transit (LRT) crossing of Power Inn Road near the intersection of Power Inn Road and Folsom Boulevard. The City has identified this crossing as a high priority for transportation improvement (SACOG 1990). In addition to the LRT crossing, the local railroad crossings at Fruitridge Road and Power Inn Road have the potential for adverse public safety impacts.

**6.5.1.1.2 Programs to improve traffic circulation.** The Sacramento Council of Governments (SACOG) and other area governments have been very active in implementing studies and programs in an attempt to maintain acceptable levels of service on area roadways and to develop a long-term transportation strategy. As a result of these efforts, several programs have been proposed or implemented to encourage more efficient use of the transportation network, including the designation of high occupancy vehicle (HOV) lanes on the major highways in the vicinity of downtown Sacramento and limited access roadways (Sacramento County Planning Department 1992).

5 Another major program which contributes toward a more efficient use of the transportation network is the City of Sacramento's Transportation Systems Management (TSM) program which is intended to encourage 35 percent of the peak period commuters to use alternative commute modes through mandated employer programs for businesses.

3 Businesses affected by the City's TSM ordinance are those which employ 25 or more workers. Businesses that employ between 25 and 99 people are designated as Minor Projects; those with 100 or more are Major Projects. Minor Projects are required to post information regarding available transit service in the vicinity of the work site; carpool, vanpool, and bicycle facilities available at the site; and where to obtain additional information about ridesharing and transit (Department of Public Works 1989).

Major Project employers are required to submit a Transportation Management Plan (TMP) to the City Traffic Engineer, and this TMP must be approved and a certificate obtained before an Occupancy Permit is issued. Approval is based on

whether the TMP adequately contributes toward meeting the 35 percent alternative commute mode goal. The City may require modifications to a proposed TMP. A wide variety of programs may qualify as an alternative commute mode program. These programs include offering transportation coordinator services; providing carpool/vanpool matching services; offering priority parking assignments to carpools or vanpools; providing current transit information; discounting parking costs for car/vanpools; providing transit shelters; providing subsidies for transit passes, carpools, and vanpools; providing showers and lockers for walkers and bicyclers; posting information regarding the use of alternative commute modes; offering flex time; and providing subsidies for TSM capital improvements (Department of Public Works, Transportation Division 1991).

The projected levels of congestion on the local roadway network have resulted in numerous identified needed capital improvements to the regional highway network. Figure 6.5-2 is a map indicating the proposed capital improvements as identified in the SACOG 1992 Regional Transportation Plan. As seen in the figure, these proposed roadway facilities include a number of modified or proposed interchanges on the major highways, a proposed extension of Highway 99, and proposed arterials. The total estimated cost of these improvements to the regional roadways is approximately \$2 billion in 1991 dollars (SACOG 1992). In addition, the 1992 regional transportation plan includes the proposed addition of numerous HOV segments within and near the City of Sacramento. These HOV lanes, shown on Figure 6.5-3, are estimated to cost approximately \$436 million in 1991 dollars (SACOG 1992).

**6.5.1.1.3 Bus and rail service.** In addition to the programs implemented to improve occupancy levels of automobiles, opportunities for utilization of bus service and passenger light rail transit (LRT) service are numerous. Bus lines offering intercity as well as local service include Greyhound, Trailways, and Sacramento Regional Transit. Regional Transit operates more than 200 buses throughout Sacramento County. Routes and schedules are designed to mesh with the LRT system which has operated since 1988 (Sacramento Metropolitan Chamber of Commerce 1992).

The 1992 Regional Transportation Plan identifies a long range need for additional express bus service to downtown Sacramento during peak hours at 15 minute intervals from Elk Grove, Folsom, Rocklin, Roseville, Metro Airport, Woodland, and Davis. The estimated cost is \$10 million in 1991 dollars (SACOG).

The LRT system currently has 18 miles of track which generally follow the Business 80 and Highway 50 freeways out of downtown Sacramento to the northeast and east, respectively. The LRT has nearly 3,700 parking spaces at remote locations

to allow for easy commuter access. The existing light rail network, which tracks Highway 50, lies approximately 2.5 miles north of the site by car, and there are LRT stations near the site adjacent to Power Inn Road and another near the intersection of Kiefer Boulevard and Folsom Boulevard. Regional Transit plans to expand the system to some 100 miles of track during the next 20 years (Sacramento Metropolitan Chamber of Commerce 1992). These expansions will enable transport between downtown, Metro Airport, Davis, Elk Grove, Folsom, and Roseville. During the 1990s, existing lines are expected to be extended by about 6 miles, and a new 10 mile line to the south is scheduled.

23A The LRT expansion plans are consistent with the 1992 Regional Transportation Plan, which identified approximately 65 miles of LRT addition needs, 36.5 miles of which were classified as short-term projects. The LRT additions identified in the 1992 Regional Transportation Plan are shown on Figure 6.5-3 with the HOV network proposed for the region. The estimated cost of these additions is approximately \$1.2 billion in 1991 dollars (SACOG 1992).

12 & 12A Interregional passenger rail service is provided by Amtrak, which serves Sacramento with five trains a day from the Southern Pacific depot downtown west to the San Francisco Bay area. One of the five continues to Los Angeles. There are also four departures daily south into the Central Valley, and one train a day north to Seattle and east to Chicago. Amtrak can also be boarded in the cities of Roseville and Davis (Sacramento Metropolitan Chamber of Commerce 1992).

23 Transcontinental and interstate rail freight service is provided by the Southern Pacific and Union Pacific Railroads. Both railways have enough track, terminal, and repair facilities to meet demand for the next 20 years (County of Sacramento 1992). In 1992, the Union Pacific hauled between 10 and 20 million tons of freight and the Southern Pacific hauled over 20 million tons of freight (County of Sacramento 1992). The Sacramento Northern Railroad also serves the area. This railroad is a short line owned by the Union Pacific Railroad which offers rail service to Sacramento Valley markets. The Central California is another short line serving the area. This line runs from Stockton to Sacramento and is jointly owned by the Santa Fe, Southern Pacific, and Union Pacific Railroads (Webb 1993). The Central California is one of the proposed LRT corridors designated in the 1992 Regional Transportation Plan (SACOG 1992). The project site is just east of the Southern Pacific rail line, separated by an open field, and lies immediately south of the Central California rail line.

Nonpassenger rail freight through Sacramento occurs on a "run extra" basis, which means that freight shipments do not occur according to a regularly scheduled timetable. It is estimated that the Southern Pacific averages roughly 24 through trips per day, the Union Pacific averages roughly 12 through trips per day, and the Central California averages no more than one train per day (Webb 1993). Each of these lines has capacity for a significant increase in the volume of trains with proper scheduling and signalization (Webb 1993).

The Port of Sacramento (Port) is owned and operated by the Port Authority which includes Yolo County, Sacramento County, and the City of Sacramento (County of Sacramento 1992). The Port provides direct ocean freight service to all major ports in the US and to world ports. It is a deepwater ship channel located 79 nautical miles northeast of San Francisco and has a five docked ship capacity. The three major rail links serving Sacramento connect with the Port. Interstates 80 and 5 are immediately adjacent to the Port. The Port plays a major role in economic development in the County, particularly in the area of agricultural and timber product exports. In 1990, the Port handled 1.27 million short tons of cargo; nearly 1 million of this was outbound tonnage and the remainder was inbound tonnage (Sacramento Metropolitan Chamber of Commerce 1992). The Port is undertaking the dredging of the channel from the existing 30 feet to a modified depth of 35 feet, expanding its capacity to service bulk cargo vessels which currently are unable to use the Port's facilities. Plans are underway to further diversify shipping through container operations. The plan for expansion will take three to four years and cost an estimated \$45 million (Sacramento Metropolitan Chamber of Commerce 1992). The funding will come from local government and private sector financing. These improvements are expected to result in a 3 percent annual growth rate in use of the Port (County of Sacramento 1992).

Two major public airports serve the Greater Sacramento Area. The larger is the Sacramento Metropolitan Airport, the other is the Sacramento Executive Airport. The Sacramento Metropolitan Airport is a modern facility 12 miles north of downtown Sacramento, off Interstate 5. Built in 1967, the Metropolitan Airport now comprises 4,800 acres, with additional land purchases underway. In 1990, more than 3.6 million passengers used the airport, and continued growth is expected as more passengers recognize Metropolitan Airport's convenience, availability of flights, and competitive air fares (Sacramento Metropolitan Chamber of Commerce 1992). Current expansions will enable the airport to accommodate more than 8,000,000 passengers annually. The airport's rural location will allow for additional future

expansion without the problems of encroachment and incompatible land use often associated with airports in other metropolitan areas. Eight major airlines and several commuter carriers serve the airport.

Executive Airport, in Sacramento, is a full-service, 680 acre facility serving general aviation. Franklin Field is another County-operated airport serving general aviation. In addition to the above primary airports, there are numerous private airports within the Sacramento area, and South Lake Tahoe has its own commercial airport. Two large military air force bases are located in Sacramento: Mather Air Force Base and McClellan Air Force Base. Mather Air Force Base is proposed for closure by the US military (Sacramento County 1992).

**6.5.1.2 Local Roadways and Traffic.** The local transportation network in the project vicinity is shown on Figure 6.5-4. The site is in the southeast portion of the City of Sacramento, just west of and at the end of 83rd street, north of Fruitridge Road. Fruitridge Road is an east-west four lane roadway having a center turn lane in proximity to the site. Access to the site is facilitated by its proximity to Highway 50, an east-west multilane state highway approximately 3 miles north of the site by car, and Highway 99, a north-south multilane state highway approximately 4 miles west of the site by car.

From the east, on Highway 50, the site can be reached by exiting on South Watt Avenue (a designated truck route), proceeding south to Fruitridge Road, then west to 83rd Street, and north to the site. An alternative is to take Watt Avenue south to westbound Kiefer Boulevard, turning south on Florin Perkins Road, then west on 24th Avenue to the site.

The Howe Avenue/Power Inn Road exit also provides quick access to the site from Highway 50. One option is to go south on Power Inn Road to Fruitridge Road, then turn east to 83rd Street. Another alternative is to turn east on Folsom Boulevard as it intersects with Howe Avenue/Power Inn Road, then proceed on Jackson Road to Florin Perkins Road south, turning west on 24th Avenue to the site.

From the west on Highway 50, the 65th Street Expressway provides access south to Fruitridge Road, then east to 83rd Street, and north to the site. From the south, Highway 99 provides access to Fruitridge Road via Martin Luther King Boulevard. There is also an exit ramp onto Fruitridge Road from southbound Highway 99.

The local streets in the project vicinity are within the city limits and under the City of Sacramento's jurisdiction, with the exception of a small strip of Fruitridge Road and South Watt Avenue south of Folsom Boulevard. On the aforementioned

city streets, the load limit for tractor trailers is 20,000 pounds per two axles. With  
6 permits, the legal load can be increased to 60,000 pounds per two axles (City of Sac-  
ramento 1993). Permits are also required for a load in excess of 8 feet 6 inches wide  
6 (City of Sacramento 1993). For South Watt Avenue between Folsom Boulevard and  
Fruitridge Road, the weight limits without permit vary with the distance between  
axles, but for most truck loads, these limits are between 34,000 and 39,000 pounds  
9 per axle and can be exceeded with a permit (Nakaga 1993). Permits are also  
9 required along this stretch for loads in excess of 8 feet wide (Nakaga 1993).

The City of Sacramento General Plan classifies each of the streets identified  
above as a part of the City's major street system. Highway 99 and Highway 50 are  
classified as freeways; Fruitridge Road, Power Inn Road, Stockton Boulevard, and  
what is now South Watt Avenue are classified as arterials. Florin Perkins Road,  
Jackson Road, and Folsom Boulevard are classified as minor arterials; and  
1A 65th Street is classified as an expressway (City of Sacramento 1986).

An arterial is defined as a facility that provides intracity transportation and inter-  
region transportation for large volumes of vehicles, and provides access to abutting  
properties. A minor arterial is a roadway that connects major facilities, but has more  
access than a principal arterial. Parking is allowed, but may be limited. The  
General Plan defines an expressway as a roadway with limited access, few cross  
streets, limited driveway access and no on-street parking. A freeway is a grade sepa-  
1A rated roadway with limited access (City of Sacramento 1986).

**6.5.1.2.1 Local traffic volumes.** Existing average daily traffic volumes (ADT) for  
local roadways are presented on Figure 6.5-4. Fruitridge Road is a major carrier of  
eastbound and westbound traffic. The heaviest traffic flow on Fruitridge Road occurs  
4 west of Power Inn Road where the ADT is 20,700 vehicles (all volumes for city  
streets are from the City of Sacramento 1993). Between Power Inn Road and Florin  
Perkins Road, the ADT on Fruitridge Road is approximately 14,100 vehicles and  
declines to approximately 9,850 vehicles between Florin Perkins Road and South  
Watt Avenue.

The ADT volume on 65th Street Expressway, between Fruitridge Road and 14th  
Avenue is 20,600 vehicles. On Power Inn Road, the ADT is approximately  
23,150 vehicles between Fruitridge Road and 14th Avenue. The ADT on Florin  
Perkins Road between Fruitridge Road and 14th Avenue is 18,600. This compares  
to an ADT of approximately 18,000 vehicles on South Watt Avenue between Fruit-  
ridge Road and Jackson Road.

Highway 50 near the vicinity of the project moves high volumes of traffic, and these volumes generally are the highest near the central business district. In 1991, the ADT on Highway 50 at the Watt Avenue Interchange was 144,000 vehicles per day. This figure increased to 170,000 vehicles per day at the Howe Avenue Interchange and 179,000 at the 65th Street Interchange. The ADT volume increased to 186,000 at the 59th Street Interchange and to 184,000 at the Stockton Boulevard Interchange. The ADT is 187,000 at the junction of Highway 99, and reached a maximum of 193,000 vehicles at the 15th/16th Streets Interchange (Caltrans 1992).

The 1991 ADTs along Highway 99 in the project vicinity are not as high as those on Highway 50, but significant, nevertheless. The 1991 ADT on Highway 99 at the Florin Road Interchange was 130,000. This number increased to 146,000 at the 47th Avenue Interchange, and to 146,000 at the Martin Luther King Jr. Boulevard Interchange. At the Fruitridge Road Interchange, the ADT was 140,000 in 1991. The maximum ADT volumes in 1991 on Highway 99 occurred at the 12th Avenue Interchange (148,000) and at the junction of Route 51 and Route 50 (161,000) (Caltrans 1992).

**6.5.1.2.2 Levels of service on local roads.** Subsection 6.5.1.2 discussed the routes that would most likely be taken to the site, based on current usage and capacities, distance and time of travel, and discussion with the City of Sacramento and CEC staff. These routes are called the expected primary commuter routes (PCRs).

Given the expected concentration of project traffic on the PCRs, an analysis was undertaken to determine the current level of service (LOS) on these area roadways. Once the LOS is determined, project traffic can be added to determine the impacts, if any, of project traffic. A computer model developed by the Transportation Research Board (TRB) was used to estimate the LOS along the primary commuter routes. LOS is a qualitative measure describing operational conditions within a traffic stream (Transportation Research Board 1985). The TRB model has six LOS ratings, A through F, which are defined in Table 6.5-3 for signalized and unsignalized intersections. Generally, an LOS of A is indicative of free traffic flow, no delays, and no driver discomfort due to the presence of other drivers. The LOS deteriorates with lower ratings. An LOS of F represents a breakdown of traffic flow, significant delays, and extreme driver discomfort due to traffic congestion. For signalized intersections, when the volume to capacity ratio exceeds 1.2, the TRB model does not assign an LOS but rather indicates by an asterisk (\*) that an LOS is not meaningful. The asterisk may be interpreted as causing even greater delay than under an LOS of F.



### **6.5.2 Project Significance Criteria**

The remainder of Section 6.5 evaluates the probable impact of the Procter & Gamble Cogeneration Project on the regional transportation network. No significant increase in the demand for air and water transportation services are expected; therefore, the focus will be on whether the project will result in a significant impact on the roadway network during construction or operation. Ultimately, conclusions regarding the significance of project impacts depends on the significance criteria used by the City of Sacramento since the project and roadways near the project are within the city limits.

The City of Sacramento General Plan, Transportation Element, Goal D, states that the City will work toward achieving an overall level of service of C on the City's local and major street systems. This goal is somewhat ambiguous as it does not specify the meaning of what is "working toward" or the "overall" level of service of C. The goal does not explicitly state that a level of service below C is now allowed and, in fact, many of the roadways in the project vicinity are not currently at a level of service of C and are not projected to be at a level of service C with or without the project.

The City of Sacramento Transportation Division was contacted for clarification regarding the level of service standards and acceptable project impacts. The City Transportation Division interprets the goal as meaning that for those locations at a level of service of C or above, a significant impact requiring mitigation occurs when a project results in a decrease in the level of service rating. For locations with an existing level of service below C, a significant project impact, one requiring mitigation, occurs when the project results in an increase in the peak volume to capacity ratio of more than two-one hundredths to a location (0.02) (Clark 1993). However, these standards are not applied to the construction phase of a project, only the operational phase (Clark 1993). Likewise, the City's TSM ordinance, a primary program designed to "work toward" acceptable levels of service, does not require temporary construction activities to conform to the ordinance (City of Sacramento Transportation Division 1991).

### **6.5.3 Construction Impacts**

Construction of the Procter & Gamble Cogeneration Project will have an insignificant impact on the Sacramento MSA regional transportation network. Due to the relatively small size of the peak construction workforce (181 workers at peak) the only noticeable impact will be localized near the construction site. The local impact

The level of service (LOS) at the eight LOS locations identified on Figure 6.5-4 during the peak construction period was estimated using the Transportation Research Board model described in Subsection 6.5.1.2.2. The approach taken was to escalate the existing peak a.m. and p.m. traffic counts to derive the baseline conditions in May 1996. Construction traffic and deliveries were then added to determine the project impacts. The City of Sacramento Transportation Division was contacted for input regarding an appropriate escalation rate for application to the 1993 counts which accounted for cumulative changes in land uses in the vicinity of the project, including the proposed land use changes at the US Army Depot. Based upon the City's long-term traffic growth rate projections for the project vicinity, using the SACMET model, it was determined that the traffic volumes over primary commuter routes will realize an annual average growth rate of approximately 3.3 percent through the project construction and initial operation period (City of Sacramento 1993). This rate was applied to the 1993 traffic count volumes to derive the baseline conditions in the analysis and represents the cumulative increase in traffic in the project vicinity including all known changes in land uses and traffic patterns.

**6.5.3.3.1 Level of service results.** Level of service results are indicated in Table 6.5-6. The first two columns with LOS ratings indicate the LOS expected under May 1996 baseline conditions, when project employment is at its peak. As seen in the table, many LOS locations are projected to have a low LOS rating, particularly the intersection of Folsom Boulevard and Power Inn Road. The intersection of Fruitridge Road and Power Inn Road is also expected to realize low LOS ratings during the p.m. peak hour, as is the intersection of Fruitridge Road and South Watt Avenue.

Once the 1996 baseline LOS ratings were derived, construction volumes were added to derive project impacts. As indicated in Table 6.5-6, project impacts on the peak LOS are expected to be insignificant. During the a.m. peak hour, no impacts are expected since, based on working hours of 7:00 a.m. to 3:30 p.m., all project traffic passes through the LOS locations before the a.m. peak. During the p.m. rush hour, project traffic passes through six LOS locations coincident with their p.m. peak hour, but only southbound traffic on 83rd Street is projected to experience a decrease in LOS (from D to E).

Because the a.m. construction traffic will pass through all LOS locations between 6:00 a.m. and 7:00 a.m., a prepeak period, a separate analysis was performed for this time period. Results are presented in the final two columns in Table 6.5-6. As

7 Inn Road, at Fruitridge Road and Power Inn Road, and at Fruitridge Road and South Watt Avenue. It is noted, however, that the 4-way stop at the intersection of Fruitridge Road and South Watt Avenue has been identified as an intersection warranting signalization by transportation consultants hired by the City (K. D. Anderson Transportation Engineers 1993). If this occurs, the LOS will improve significantly. For modeling purposes, traffic was routed over the primary commuter routes in the same proportion as in the construction LOS analysis. The analysis assumed one worker per vehicle and working hours of 8:00 a.m. to 5:00 p.m. LOS modeling results are presented in Table 6.5-7. Because of the small volume of traffic and passage through the LOS locations in the evening during a non-peak hour, no location is expected to experience a decrease in peak LOS due to project operation. The analysis also indicated that the volume to capacity ratio, a measure of the ability of a road to accommodate additional traffic, did not decrease by 0.02 percent or more for any intersection with an LOS rating of below C. Based on the City's evaluation criteria discussed in Subsection 6.5.2, plant operation will not significantly impact the transportation network.

#### **6.5.5 Traffic Cumulative Impacts**

The LOS analyses performed for the construction and operational periods were based on the City of Sacramento's estimate of cumulative traffic levels in the project vicinity. These estimates included expected and proposed changes to the land uses in the vicinity of the project and therefore, no additional analyses are warranted.

#### **6.5.6 Mitigation**

**6.5.6.1 Construction.** As discussed in Subsection 6.5.3.3.1, construction of the Procter & Gamble Cogeneration Project will have some impacts on area roadways in the vicinity of the site. However, these marginal impacts are expected to be insignificant and temporary. These insignificant impacts are attributed to the relatively small workforce; and the encouragement of carpooling. Based on the City's evaluation criteria, no further mitigation is required to reduce project traffic volumes during construction.

Other mitigation activities include those associated with delivery of hazardous materials, wide loads, and increased rail traffic. All shipments of hazardous materials will comply with all applicable laws, ordinances, regulations, and standards for the safe transportation of these materials. Wide loads and loads in excess of normal weight limits will be properly permitted, marked and, if necessary, escorted. Any restrictions requiring daytime transportation will also be observed. Although some

project results in a decrease in the LOS rating. For locations with an existing LOS below C, a significant impact is defined as that in which the project results in an increase in the peak volume to capacity ratio of more than 0.02. The City considers these impacts only for operating conditions and does not apply these evaluation standards to the construction period (Clark 1993). On the basis of the City's evaluation criteria, the project will comply with the level of service criteria.

The City has chosen to work toward a level of service of C through a number of transportation programs, including the TSM ordinance in which employers are required to encourage and promote alternative transportation modes. The project will comply with the TSM ordinance.

### 6.5.8 References

1. City of Sacramento, 1993, *Circulation Element, Sacramento Army Depot Site Planning and Environmental Assessment*, preliminary.
- 1A. City of Sacramento, 1986, *Circulation Element, City of Sacramento General Plan*.
2. City of Sacramento, July 1991, Transportation Division, *TSM Employer Guidelines*.
3. City of Sacramento, March 1989, Transportation Division, *Developer Transportation Systems Management Handbook*.
4. Clark, Pelle, City of Sacramento, May 11, 1993, Transportation Division, in personal communication with John Wynne, Black & Veatch.
5. County of Sacramento, December 9, 1992, *Planning and Community Development Department, Revised Draft Circulation Element of the County of Sacramento General Plan*.
6. Evans, Bud, City of Sacramento, California, May 11, 1993, Transportation Division, in personal communication with John Wynne, Black & Veatch.
7. K. D. Anderson Transportation Engineers, February 15, 1993, *Sacramento Army Depot Site Planning and Environmental Assessment*.
8. Metro Design & Tech, May 27, 1993, traffic counts collected for Black & Veatch.
9. Nakaga, Dennis, June 10, 1993, County Transportation Department, in personal communication with John Wynne, Black & Veatch.

10. Sacramento Area Council of Governments, January 1990, *Hazardous Waste Management Plan for the SACOG Region*.
11. Sacramento Area Council of Governments, December 1989, *Sacramento Metropolitan Area Transportation Study, Technical Report*.
12. Sacramento Area Council of Governments, February 1992, *1992 Regional Transportation Plan Technical Appendix*.
- 12A. Sacramento Area Council of Governments, February 1992, *1992 Regional Transportation Plan*.
13. Sacramento Area Council of Governments, December 1990, *1992 Regional Transportation Plan, Working Paper #3: Existing Condition and Projections*.
14. Sacramento Area Council of Governments, December 1990, *1992 Regional Transportation Plan, Working Paper #4: Definition of Regional Mobility Problems*.
15. Sacramento Area Council of Governments, 1985, *Year 2010 Report*.
16. Sacramento Area Council of Governments, 1988, *Metro Study Summary Report*.
17. Sacramento Area Council of Governments, June 1, 1989, *Strategic Transportation Planning Study, Summary Report*.
18. Sacramento Area Council of Governments, April 1992, *Transportation Development Act Guidelines*.
19. Sacramento Area Council of Governments, February 1992, *Sacramento Area Planning and Implementation Guidelines for Shuttle Services*.
20. Sacramento Area Council of Governments, 1992, *Suburban Mobility Project, Getting From Here to There... Unsnarling Sacramento's Suburban Traffic*.
21. Sacramento Metropolitan Chamber of Commerce, 1992, *Greater Sacramento Area Statistical Abstract*.
22. Sacramento Metropolitan Chamber of Commerce, 1992, *Welcome to Sacramento Newcomer's Map*.
23. Sacramento Metropolitan Chamber of Commerce, 1991, *All About Business in Sacramento, 1991/1992*.

- 23A. Sacramento Metropolitan Chamber of Commerce, 1992, *Sacramento Today, 1992-1993*.
24. Sacramento Metropolitan Chamber of Commerce, 1992, *All About Living in Sacramento, 1992-1993*.
25. Sacramento Regional Transit District, April 4, 1993, *Bus and Light Rail Timetables*.
26. State of California, June 1992, Transportation and Housing Agency, Department of Transportation, Division of Traffic Operations, *1991 Traffic Volumes on the California State Highway System*.
27. State of California, 1982, Caltrans Division of Mass Transportation, *California State Railroad Map*.
28. Transportation Research Board, 1985, *Highway Capacity Manual, Special Report 209*, Washington, D.C.
29. Webb, Robert, June 10, 1993, California Public Utilities Commission, in personal communications with John Wynne, Black & Veatch.
30. Williamson, Bonnie, May 11, 1993, City of Sacramento Transportation Division, in personal communications with John Wynne, Black & Veatch.

- $c_i$  = capacity of lane group or approach  $i$  in vph; -
- $s_i$  = saturation flow rate for lane group or approach  $i$  in vphg; and
- $(g/C)_i$  = green ratio for lane group or approach  $i$ .

The ratio of flow rate to capacity,  $v/c$ , is given the symbol  $X_i$  in intersection analysis. This new symbol is introduced in this chapter to emphasize the strong relationship of capacity to signalization conditions, and for consistency with the literature, which also refers to this variable as the "degree of saturation."

For a given lane group or approach  $i$ :

$$X_i = (v/c)_i = v_i / [s_i \times (g/C)_i] \tag{9-2}$$

$$X_i = v_i / s_i g_i = (v/s)_i / (g/C)_i$$

where:

- $X_i$  =  $v/c$  ratio for lane group or approach  $i$ ;
- $v_i$  = actual flow rate for lane group or approach  $i$  in vph;
- $s_i$  = saturation flow rate for lane group or approach  $i$  in vphg; and
- $g_i$  = effective green time for lane group  $i$  or approach  $i$  in sec.

Values of  $X_i$  range from 1.00 when the flow rate equals capacity to 0.00 when the flow rate is zero.

The capacity of the full intersection is not a significant concept and is not specifically defined herein. Rarely do all movements at an intersection become saturated at the same time of day. It is the ability of individual movements to move through the intersection with some efficiency which is the critical concern.

Another capacity concept of utility in the analysis of signalized intersections is, however, the *critical v/c ratio,  $X_c$* . This is a  $v/c$  ratio for the intersection as a whole, considering only the lane groups or approaches that have the highest flow ratio,  $v/s$ , for a given signal phase.

For example, in a two-phase signal, opposing approaches move during the same green time. Generally, one of these two approaches will require more green time than the other (i.e., it will have a higher flow ratio). This would be the "critical" approach for the subject signal phase. Each signal phase will have a critical lane group or approach that determines the green time requirements for the phase. Where signal phases overlap, the identification of these critical lane groups or approaches is somewhat complex, and is discussed in the "Methodology" section of this chapter.

The critical  $v/c$  ratio for the intersection is defined in terms of critical lane groups or approaches:

$$X_c = \sum (v/s)_c \times [C / (C-L)] \tag{9-3}$$

where:

- $X_c$  = critical  $v/c$  ratio for the intersection;
- $\sum (v/s)_c$  = the summation of flow ratios for all critical lane groups or approaches,  $i$ ;
- $C$  = cycle length, in sec; and
- $L$  = total lost time per cycle; computed as the sum of "start-up" and change interval lost

time minus the portion of the change interval used by vehicles for each critical signal phase.

This equation is useful in evaluating the overall intersection with respect to the geometrics and total cycle length provided, and is also useful in estimating signal timings where they are not known or specified by local policies or procedures. It gives the  $v/c$  ratio for all critical movements, assuming that green time has been appropriately or proportionally allocated. It is therefore possible to have a critical  $v/c$  ratio of less than 1.00, and still have individual movements oversaturated within the signal cycle. A critical  $v/c$  ratio less than 1.00, however, does indicate that all movements in the intersection can be accommodated within the defined cycle length and phase sequence by proportionally allocating green time. In essence, the total available green time in the phase sequence is adequate to handle all movements if properly allocated.

The analysis of capacity in this chapter focuses on the computation of saturation flow rates,  $v/c$  ratios, and capacities for various approaches or lane groups at the intersection. Procedures for these computations are described in greater detail in the "Methodology" and "Procedures for Application" sections of this chapter.

#### Level of Service for Signalized Intersections

Level of service for signalized intersections is defined in terms of *delay*. Delay is a measure of driver discomfort, frustration, fuel consumption, and lost travel time. Specifically, level-of-service criteria are stated in terms of the average stopped delay per vehicle for a 15-min analysis period. The criteria are given in Table 9-1.

Delay may be measured in the field, or may be estimated using procedures presented later in this chapter. Delay is a complex measure, and is dependent on a number of variables, including the quality of progression, the cycle length, the green ratio, and the  $v/c$  ratio for the lane group or approach in question.

*Level-of-service A* describes operations with very low delay, i.e., less than 5.0 sec per vehicle. This occurs when progression is extremely favorable, and most vehicles arrive during the green phase. Most vehicles do not stop at all. Short cycle lengths may also contribute to low delay.

TABLE 9-1. LEVEL-OF-SERVICE CRITERIA FOR SIGNALIZED INTERSECTIONS

LEVEL OF SERVICE	STOPPED DELAY PER VEHICLE (SEC)
A	≤ 5.0
B	5.1 to 15.0
C	15.1 to 25.0
D	25.1 to 40.0
E	40.1 to 60.0
F	> 60.0

*Level-of-service B* describes operations with delay in the range of 5.1 to 15.0 sec per vehicle. This generally occurs with good progression and/or short cycle lengths. More vehicles stop than for LOS A, causing higher levels of average delay.

*Level-of-service C* describes operations with delay in the range of 15.1 to 25.0 sec per vehicle. These higher delays may result from fair progression and/or longer cycle lengths. Individual cycle failures may begin to appear in this level. The number of vehicles stopping is significant at this level, although many still pass through the intersection without stopping.

*Level-of-service D* describes operations with delay in the range of 25.1 to 40.0 sec per vehicle. At level D, the influence of congestion becomes more noticeable. Longer delays may result from some combination of unfavorable progression, long cycle lengths, or high  $v/c$  ratios. Many vehicles stop, and the proportion of vehicles not stopping declines. Individual cycle failures are noticeable.

*Level-of-service E* describes operations with delay in the range of 40.1 to 60.0 sec per vehicle. This is considered to be the limit of acceptable delay. These high delay values generally indicate poor progression, long cycle lengths, and high  $v/c$  ratios. Individual cycle failures are frequent occurrences.

*Level-of-service F* describes operations with delay in excess of 60.0 sec per vehicle. This is considered to be unacceptable to most drivers. This condition often occurs with oversaturation, i.e., when arrival flow rates exceed the capacity of the intersection. It may also occur at high  $v/c$  ratios below 1.00 with many individual cycle failures. Poor progression and long cycle lengths may also be major contributing causes to such delay levels.

#### Relating Capacity and Level of Service

Because delay is a complex measure, its relationship to capacity is also complex. The levels of service of Table 9-1 have been established based on the acceptability of various delays to drivers. It is important to note that this concept is not related to capacity in a simple one-to-one fashion.

In previous chapters, the lower bound of LOS E has always been defined to be capacity, i.e., the  $v/c$  ratio is, by definition, 1.00. This is *not the case* for the procedures of this chapter. It is possible, for example, to have delays in the range of LOS F (unacceptable) while the  $v/c$  ratio is below 1.00, perhaps as low as 0.75-0.85. Very high delays can occur at such  $v/c$  ratios when some combination of the following conditions exists: (1) the cycle length is long, (2) the lane group in question is disadvantaged (has a long red time) by the signal timing, and/or (3) the signal progression for the subject movements is poor.

The reverse is also possible: a saturated approach or lane group (i.e.,  $v/c$  ratio = 1.00) may have low delays if: (1) the cycle length is short, and/or (2) the signal progression is favorable for the subject movement. Thus, the designation of LOS F does *not* automatically imply that the intersection, approach, or lane group is overloaded, nor does a level of service in the A to E range automatically imply that there is unused capacity available.

The procedures and methods of this chapter require the analysis of both capacity and level-of-service conditions to fully evaluate the operation of a signalized intersection. It is imper-

ative that the analyst recognize the unique relationship of these two concepts as they apply to signalized intersections.

#### LEVELS OF ANALYSIS

This chapter presents two levels of analysis for use. The primary methodology used is *operational analysis*. At this level, detailed information on all prevailing traffic, roadway, and signalization conditions must be provided. The method provides for a full analysis of capacity and level of service, and can be used to evaluate alternative geometric designs and/or signal plans.

A second methodology is provided for *planning analysis*. At this level, only capacity is addressed, because the detailed information needed to estimate delay is not available. Information on intersection geometrics and turning movements is required, but the details of signalization and vehicle type distributions are not needed. The method provides broad results that allow a projection of whether or not the intersection is likely to be oversaturated. Inasmuch as delay estimates cannot be made in planning analysis, level of service cannot be addressed at this level.

Operational analysis would be used in most analyses of existing intersections and of future situations in which traffic, geometric, and control parameters were well established by projections and final designs. The planning procedure is useful in testing general design alternatives for new intersections in areas of new development, where details of signalization and demand characteristics are not yet under consideration.

The operational analysis methodology provided considers the full details of each of four components: demand or service flow rates at the intersection, signalization of the intersection, geometric design or characteristics of the intersection, and the delay or level of service that results from these. The methodology is capable of treating any of these four as an "unknown," to be determined knowing the details of the other three. Thus the method can be used to:

1. Solve for level of service, knowing details of intersection flows, signalization, and geometrics.
2. Solve for allowable service flow rates for selected levels of service, knowing the details of signalization and geometrics.
3. Solve for signal timing (for an assumed phase plan), knowing the desired level of service and the details of flows and geometrics.
4. Solve for basic geometrics (number or allocation of lanes), knowing the desired level of service and the details of flows and signalization.

While the methodology is capable of computation in all four modes, specific procedures and worksheets herein are designed for the first of these, i.e., a solution for level of service. In developing alternative signal and geometric designs, it is often necessary to consider simultaneous changes in both. Rarely is signalization to be considered in isolation from geometric design and vice-versa. Thus, the most frequent type of analysis would consider such alternatives on a trial-and-error basis, and would not attempt to hold one constant and "solve" for the other. Sample calculations, however, illustrate alternative uses of the methodology.



Table 3.6-1

Critical Structure	Formula	Seismic Zone Factor (Z)	Importance Factor (I)*	Horizontal Force Factor (C or Cp)	Numerical Coefficient (Rw)
Buildings	UBC 34-1	0.30	1.25	2.75** = C	8**
Caustic, acid, and ammonia storage tanks and their foundations and anchorages	UBC 36-1	0.30	1.50	0.75 = Cp	NA
Foundations and anchorages for steam and combustion turbine/generator and wet surface condenser	UBC 36-1	0.30	1.25	0.75 = Cp	NA
Foundation and anchorages for heat recovery steam generator	UBC 36-1	0.30	1.25	0.75 = Cp	NA
Heat recovery steam generator exhaust stack, its foundation and anchorage	UBC 34-1	0.30	1.25	2.75 = C	4
Inlet Air Filtration Equipment	UBC 36-1	0.30	1.25	0.75 = Cp	NA
Inlet Air Duct Support Structure	UBC 36-1	0.30	1.25	0.75 = Cp	NA
Cooling Tower	UBC 34-1	0.30	1.25	2.75 = C	5
Elevated Deaerator Support Structure	UBC 34-1	0.30	1.25	2.75 = C	3

\*Special occupancy structures.

\*\*Value is approximate and may be revised during detailed design to reflect the final configuration.

# OVERSIZE DOCUMENT

- Too Large to Scan
- No Digital Version Available
- The complete document can be found in the Dockets Unit.