

DOCKETED

Docket Number:	09-AFC-08C
Project Title:	Genesis Solar Energy Project
TN #:	212350
Document Title:	Petition to Amend for Ammonia tanks and gas cylinder storage
Description:	in Units 1 and 2 and Gas Cylinder Storage Area in Common Area
Filer:	Eric Veerkamp
Organization:	Genesis Solar, LLC
Submitter Role:	Applicant
Submission Date:	7/18/2016 4:39:29 PM
Docketed Date:	7/18/2016

Genesis Solar, LLC

(9-AFC-8)

Petition to Amend

Submitted by

Genesis Solar, LLC

July 2016

Table of Contents

Content.....	3
Executive Summary	4
1.0 Introduction	6
1.1 Overview.....	6
1.2 Ownership of Genesis.....	7
1.3 Summary of Environmental Impacts.....	7
2.0 Description of Project Changes	8
2.1 Changes to Condition of Certification.....	8
2.2 Necessity of Proposed Changes.....	9
3.0 Environmental Analysis of Proposed Project	9
3.1 Changes and Consistency with LORS.....	9
6.0 Drawings.....	15
6.1 Ammonia Storage Area	15
6.2 Ammonia Storage Area.....	16

Content

Genesis Solar, LLC, as project owner, petitions the California Energy Commission (CEC or Commission) to amend the certification for the Genesis Solar, LLC facility (9-AFC-8) (Decision). This Petition to Amend, (Amendment), requests an addition of a Gas Cylinder storage area and an Ammonia Bulk Storage pad. Due to the extreme weather conditions in the Mojave Desert and the concerns regarding the equipment deterioration.

Executive Summary

Genesis Solar, LLC as project owner, petitions the California Energy Commission (CEC or Commission) to comply with the Condition of Certification Gen-1, Gen-8 and Struc-1 regarding the manner of regulation of new construction at the Genesis Solar Facility. Genesis Solar, LLC propose to construct a cement pad for the storage of gas cylinders to prevent rusting and over-heating of cylinders that are required to be stored in a place that is protected from direct sun light and rain. The new cylinder storage area will house approximately 12 cylinders of Argon, 12 cylinders of oxygen, 12 cylinders of nitrogen and 12 cylinders of acetylene. These gases are used for welding repairs, fabrication of parts, purging of piping, and plasma cutting. The exact number of cylinders is not known, however, they would not exceed a total of 48 cylinders at any given time.

Additionally, this proposal addresses the construction of an ammonia storage slab at both Unit 1 and Unit 2 power blocks. The slabs will house ammonia product used in the process of pH control of the condensate. The ammonia is housed in a 3100 gallon bulk tank, self-contained and double walled.

Per the CEC Condition of certification, this compliance proposal is being submitted for approval due to the following **condition decisions**.

Gen-1

The project owner shall design, construct, and inspect the project in accordance with the 2007 California Building Standards Code (CBSC), also known as Title 24, California Code of Regulations, which encompasses the California Building Code (CBC), California Building Standards Administrative Code, California Electrical Code, California Mechanical Code, California Plumbing Code, California Energy Code, California Fire Code, California Code for Building Conservation, California Reference Standards Code, and all other applicable engineering LORS in effect at the time initial design plans are submitted to the CBO for review and approval (the CBSC in effect is the edition that has been adopted by the California Building Standards Commission and published at least 180 days previously). The project owner shall ensure that all the provisions of the above applicable codes are enforced during the construction, addition, alteration, moving, demolition, repair, or maintenance of the completed facility. All transmission facilities (lines, switchyards, switching stations and substations) are covered in the conditions of certification in the **Transmission System Engineering** section of this document. In the event that the initial engineering designs are submitted to the CBO when the successor to the 2007 CBSC is in effect, the 2007 CBSC provisions shall be replaced with the applicable successor provisions. Where, in any specific case, different sections of the code specify different materials, methods of construction or other requirements, the most restrictive shall govern. Where there is a conflict between a general requirement and a specific requirement, the specific requirement shall govern. The project owner shall ensure that all contracts with contractors, subcontractors, and suppliers clearly specify that all work performed and materials supplied comply with the codes listed above. (Decision pg. 4)

GEN-8

The project owner shall obtain the CBO's final approval of all completed work that has undergone CBO design review and approval.

The project owner shall request the CBO to inspect the completed structure and review the submitted documents. The project owner shall notify the CPM after obtaining the CBO's final approval. The project owner shall retain one set of approved engineering plans, specifications, and calculations (including all approved changes) at the project site or at another accessible location during the operating life of the project. Electronic copies of the approved plans, specifications, calculations, and marked-up as-builts shall be provided to the CBO for retention by the CPM.

STRUC-1

Prior to the start of any increment of construction of any major structure or component listed in **Facility Design Table 2** of condition of certification **GEN-2**, the project owner shall submit to the CBO for design review and approval the proposed lateral force procedures for project structures and the applicable designs, plans and drawings for project structures. Proposed lateral force procedures, designs, plans and drawings shall be those for the following items:

1. Major project structures; Ammonia pad in Unit 1 and Unit 2 and the addition of the cylinder storage pad in the commons area.
2. Plans and designs are included for the major foundations, equipment supports, and anchorage; and
3. Designs for the ammonia tank pad and the cylinder storage pad.

Construction of any structure or component shall not begin until the CBO has approved the lateral force procedures to be employed in designing that structure or component.

1.0 Introduction

1.1 Overview

By this amendment Genesis Solar, LLC, petitions the Commission to consider the stated Condition of Certification to add a cylinder storage area for gas cylinders and an Ammonia bulk storage area for treatment of condensate at the Unit 1 and Unit 2 power blocks for pH control in the feed water system.

This Amendment contains all of the information that is required pursuant to the Siting Regulations (California Code of Regulations [CCR] Title 20, Section 1769, Post Certification Amendments and Changes). The information necessary to fulfill the requirements of Section 1769(a)(1) is contained in Sections 1.0 through 5.0 as summarized in Table 1 below.

TABLE 1

Informational Requirements for Post-Certification Amendments and Changes

Section 1769(a)(1) Requirement	Section of Petition Fulfilling Requirement
(A) A complete description of the proposed Modifications, including new language for any conditions that will be affected	Section 2.1 – Proposed changes in the Executive Summary
(B) A discussion of the necessity for the proposed changes	Section 1.3 -
(C) If the modification is based on information that was known by the petitioner during the certification proceeding, an explanation why the issue was not raised at that time	Section 2.2
(D) If the modification is based on new information that changes or undermines the assumptions, rationale, findings, or other bases of the final decision, an explanation of why the change should be permitted	Sections 3.2
(E) An analysis of the impacts the modification may have on the environment and proposed measures to mitigate any significant adverse impacts	Section 3.0
(F) A discussion of the impact of the modification on the facility's ability to comply with applicable laws, ordinances, regulations, and standards;	Section 3.3

TABLE 1

Informational Requirements for Post-Certification Amendments and Changes

Section 1769(a)(1) Requirement	Section of Petition	Fulfilling Requirement
(G) A discussion of how the modification affects the public	Section 4.0	
(H) A list of property owners potentially affected by the modification	Section 5.1	
(I) A discussion of the potential effect on nearby property owners, the public and the parties in the application proceedings.	Section 5.2	

1.2 Ownership of Genesis Solar, LLC

Genesis Solar, LLC, a wholly owned subsidiary of Nextera Energy Resources.

1.3 Summary of Environmental Impacts

The Siting Regulations require that an analysis be conducted to address the potential impacts the proposed project change may have on the environment and proposed measures to mitigate any potentially significant adverse impacts (Title 20, CCR, Section 1769 (a)(1)(E)). The regulations also require a discussion of the impact of the proposed change on the facility's ability to comply with applicable laws, ordinances, regulations and standards ("LORS") (Title 20, CCR Section 1769 (a)(1)(F)).

Section 3.0 of this Amendment includes a discussion of the potential environmental impacts associated with the proposed additions and a discussion of the consistency of the change with LORS. Section 3.0 concludes that there would be no significant environmental impacts associated with implementing the construction of the cylinder storage area, the ammonia slab at Unit 1 and the ammonia slab at Unit 2 specified in this Amendment and that the project would continue to comply with all applicable LORS.

The proposed changes to the site foot print will not adversely impact the environment. The proposed changes will not result in any significant physical change in the project or to the environment. The design of the plant will remain the same. Therefore, there is no possibility of any significant adverse environmental impacts resulting from the proposed changes to add the three storage areas. The amount of cylinders and bulk ammonia remain consistent with the present volumes on site.

2.0 Description of Project Changes

This section includes a complete description of the proposed modification consistent with the Siting Regulations (Title 20, CCR, Section 1769 (a)(1)(A)).

2.1 Changes to Condition of Certification

By way of background, the Decision for the Genesis Solar facility describes in GEN-1 any alterations or additions will be presented to the CPM 30 days before commencement of work.

“Once the certificate of occupancy has been issued, the project owner shall inform the CPM at least 30 days prior to any construction, addition, alteration, moving, demolition, repair, or maintenance to be performed on any portion(s) of the completed facility that requires CBO approval for compliance with the above codes. The CPM will then determine if the CBO needs to approve the work.” (Decision, pg. 4)

The original Condition of Certification to the Decision will not be affected by the addition of the Ammonia Storage and Cylinder Storage pads. The cylinder pad will be built to CBO specification and inspected by the CBO as designated by GEN-3 to GEN-8 (Decision, p. 2.) The Ammonia Storage pads will also be built to CBO specifications and inspected by the CBO. (Decision p.2)

In light of the above, this Amendment proposes the following changes:

Within 30 days following receipt of the certificate of occupancy, the project owner shall submit to the CPM a statement of verification, signed by the responsible design engineer, attesting that all designs, construction, installation, and inspection requirements of the applicable LORS and the Energy Commission’s decision have been met in the area of facility design. The project owner shall provide the CPM a copy of the certificate of occupancy within 30 days of receipt from the CBO.

Once the certificate of occupancy has been issued, the project owner shall inform the CPM at least 30 days prior to any construction, addition, alteration, moving, demolition, repair, or maintenance to be performed on any portion(s) of the completed facility that requires CBO approval for compliance with the above codes. The CPM will then determine if the CBO needs to approve the work.

Additionally, the implementation of the proposed storage areas will not adversely affect the Conditions of Certification listed to ensure that the Genesis Solar Energy Project will be designed and constructed in conformance with the applicable LORS pertinent to the engineering aspects summarized in the Decision. (Decision, p. 3)

2.2 Necessity of Proposed Changes

The Siting Regulations require a discussion of the necessity for the proposed modification to GEN 3, GEN 8 and STRUC 1 whether the additional storage areas is based on information known by the petitioner during the certification proceeding (Title 20, CCR, Sections 1769 (a)(1)(B), and (C)).

As described in Section 2.1 above, structural changes to the site does not change the decision as it is stated in GEN 3, GEN 8 and STRUC 1. The project owner did not know at the time of approval of the Decision that the storage areas would be necessary. Due to the extreme weather conditions in the Mojave Desert and the concerns regarding the equipment deterioration, Genesis Solar, LLC proposes to build and maintain the gas cylinders and Ammonia tank under a sun shielding awning and concrete slab hence keeping the integrity of the equipment.

Gas Cylinder Storage Area:

Storage area will consist of a sun shielding awning with a concrete slab. The Gas Cylinder slab will accommodate the following products;

1. Acetylene - 12 Cylinders with 150 SCF storage
2. Argon - 12 Cylinders with 330 SCF of storage or less
3. Nitrogen - 12 Cylinders with 330 SCF or less
4. Oxygen - 12 Cylinders with 330 SCF storage or less
5. See Attached Cylinder Chart.

These style cylinders are required by the manufacture not to be placed in direct sun light and not to be in the dirt, due to corrosion on the bottoms of high pressure cylinders.

The Ammonia bulk Storage Area:

Consist of a double walled, self-contained, above ground tank with a 3100 gallon capacity filled to 2800 gallons. A concrete pad and a shade cove will be installed. (See Drawings)

The Tanks are being installed due the plant usage, Currently installed are two 330 gallon tanks, one at each plant, the rate of usage is 150 gallons per week, per plant. At this rate we have to order and refill every two weeks, creating a safety issue for handling, and a procurement problem.

3.0 Environmental Analysis of Proposed Project Changes and Consistency with LORS

The changes proposed by this Amendment are evaluated below. The end of this section addresses the consistency of the proposed changes to the addition to Conditions of Certification GEN 3, GEN 8 and STRUC 1 with LORS.

The proposed change has no possible potential impact on the following environmental disciplines: Biological Resources, Cultural Resources, Geology and Paleontology, Hazardous Materials Management, Land Use, Noise and Vibration, Socioeconomics, Soil and Water Resources, Traffic and Transportation, Waste Management, and Worker Safety and Fire Protection.

3.1 No Changes to GEN 3, GEN 8 and STRUC 1

This Amendment does not modify the decision requirements regarding the construction of the 3 storage areas to accommodate a cylinder storage area, and two ammonia storage areas. . The Amendment does not change the design or operation of the plant equipment. Accordingly, the proposed addition to the plant does not modify GEN 3, GEN 8 and STRUC 1 and will not result in any significant adverse environmental impact.

3.1.1 Air Quality

The proposed changes that incorporate GEN 3, GEN 8 and STRUC 1 will not cause any change to air quality.

3.1.2 Public Health

The proposed changes that incorporate GEN 3, GEN 8 and STRUC 1 will have no effect on public health.

3.2 Consistency of Amendment with the Certification and LORS

The Siting Regulations require a discussion of the consistency of the proposed project revisions with the applicable laws, ordinances, regulations, and standards (LORS) and whether the modifications are based upon new information that changes or undermines the assumptions, rationale, findings, or other bases of the final decision (Title 14, CCR Section 1769 (a)(1)(D)). If the project is no longer consistent with the certification, the petition for project change must provide an explanation for why the modification should be permitted.

This Amendment is consistent with all applicable LORS and is not based on new information that changes or undermines any bases for the Decision. The findings and conclusions contained in the Decision for the project are still applicable to the project as modified.

4.0 Potential Effects on the Public

This section discusses the potential effects on the public that may result from the modification proposed in this request for approval, per the Siting Regulations (Title 20, CCR, Section 1769(a)(1)(G)).

The proposed changes will not affect the public.

5.0 List of Property Owners and Potential Effects on Property Owners

5.1 List of Property Owners

In accordance with the Siting Regulations (Title 20, CCR, Section 1769(a)(1)(H)), the project owner will provide the Compliance Project Manager for the project a list of all property owners whose property is located within 500 feet of the project.

There are no property owners within 500 feet of the project.

5.2 Potential Effects on Property Owners

This section addresses potential effects of the modification proposed in this Amendment on nearby property owners, the public, and parties in the application proceeding, per the Siting Regulations (Title 20, CCR, Section 1769 (a)(1)(I)).

There are no property owners within 500 feet of the project.

6.0

All Approved Drawings and Pictures are attached

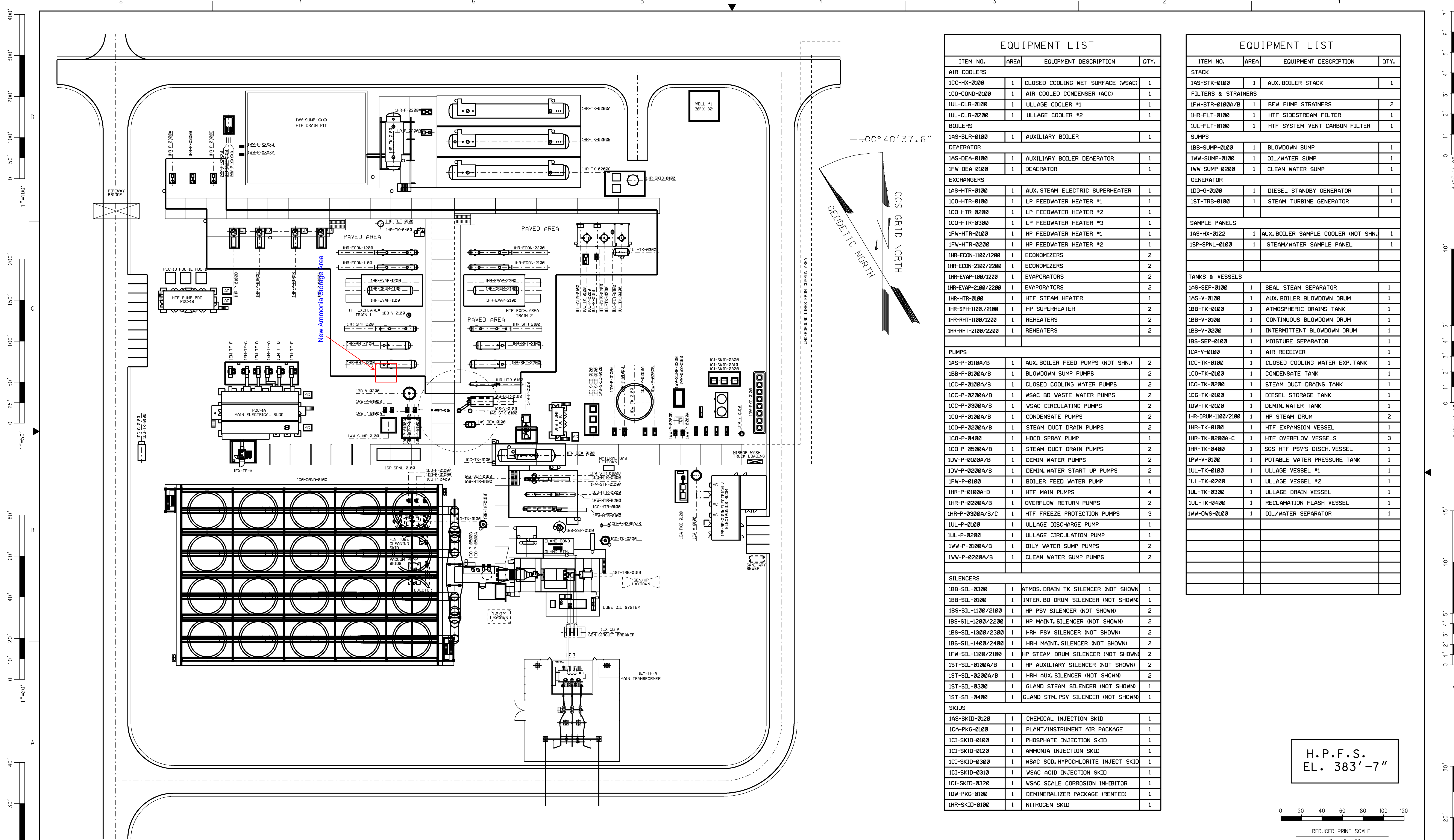

EQUIPMENT LIST			
ITEM NO.	AREA	EQUIPMENT DESCRIPTION	QTY.
AIR COOLERS			
ICC-HX-0100	1	CLOSED COOLING WET SURFACE (WSAC)	1
ICO-COND-0100	1	AIR COOLED CONDENSER (ACC)	1
IUL-CLR-0100	1	ULLAGE COOLER #1	1
IUL-CLR-0200	1	ULLAGE COOLER #2	1
BOILERS			
IAS-BLR-0100	1	AUXILIARY BOILER	1
DEAERATOR			
IAS-DEA-0100	1	AUXILIARY BOILER DEAERATOR	1
IFW-DEA-0100	1	DEAERATOR	1
EXCHANGERS			
IAS-HTR-0100	1	AUX. STEAM ELECTRIC SUPERHEATER	1
ICO-HTR-0100	1	LP FEEDWATER HEATER #1	1
ICO-HTR-0200	1	LP FEEDWATER HEATER #2	1
ICO-HTR-0300	1	LP FEEDWATER HEATER #3	1
IFW-HTR-0100	1	HP FEEDWATER HEATER #1	1
IFW-HTR-0200	1	HP FEEDWATER HEATER #2	1
IHR-ECON-1100/1200	1	ECONOMIZERS	2
IHR-ECON-2100/2200	1	ECONOMIZERS	2
IHR-EVAP-100/1200	1	EVAPORATORS	2
IHR-EVAP-2100/2200	1	EVAPORATORS	2
IHR-HTR-0100	1	HTF STEAM HEATER	1
IHR-SPH-1100/2100	1	HP SUPERHEATER	2
IHR-RHT-1100/1200	1	REHEATERS	2
IHR-RHT-2100/2200	1	REHEATERS	2
PUMPS			
IAS-P-0110A/B	1	AUX. BOILER FEED PUMPS (NOT SHN.)	2
IBB-P-0100A/B	1	BLOWDOWN SUMP PUMPS	2
ICC-P-0100A/B	1	CLOSED COOLING WATER PUMPS	2
ICC-P-0200A/B	1	WSAC BD WASTE WATER PUMPS	2
ICC-P-0300A/B	1	WSAC CIRCULATING PUMPS	2
ICO-P-0100A/B	1	CONDENSATE PUMPS	2
ICO-P-0200A/B	1	STEAM DUCT DRAIN PUMPS	2
ICO-P-0400	1	HOOD SPRAY PUMP	1
ICO-P-0500A/B	1	STEAM DUCT DRAIN PUMPS	2
IDW-P-0100A/B	1	DEMIN. WATER PUMPS	2
IDW-P-0200A/B	1	DEMIN. WATER START UP PUMPS	2
IHW-P-0100	1	BOILER FEED WATER PUMP	1
IHR-P-0100A-D	1	HTF MAIN PUMPS	4
IHR-P-0200A/B	1	OVERFLOW RETURN PUMPS	2
IHR-P-0300A/B/C	1	HTF FREEZE PROTECTION PUMPS	3
IUL-P-0100	1	ULLAGE DISCHARGE PUMP	1
IUL-P-0200	1	ULLAGE CIRCULATION PUMP	1
IWW-P-0100A/B	1	OILY WATER SUMP PUMPS	2
IWW-P-0200A/B	1	CLEAN WATER SUMP PUMPS	2
SILENCERS			
IBB-SIL-0300	1	ATMOS. DRAIN TK SILENCER (NOT SHOWN)	1
IBB-SIL-0100	1	INTER. BD DRUM SILENCER (NOT SHOWN)	1
IBS-SIL-1100/2100	1	HP PSV SILENCER (NOT SHOWN)	2
IBS-SIL-1200/2200	1	HP MAINT. SILENCER (NOT SHOWN)	2
IBS-SIL-1300/2300	1	HRH PSV SILENCER (NOT SHOWN)	2
IBS-SIL-1400/2400	1	HRH MAINT. SILENCER (NOT SHOWN)	2
IFW-SIL-1100/2100	1	HP STEAM DRUM SILENCER (NOT SHOWN)	2
IST-SIL-0100A/B	1	HP AUXILIARY SILENCER (NOT SHOWN)	2
IST-SIL-0200A/B	1	HRH AUX. SILENCER (NOT SHOWN)	2
IST-SIL-0300	1	GLAND STEAM SILENCER (NOT SHOWN)	1
IST-SIL-0400	1	GLAND STM. PSV SILENCER (NOT SHOWN)	1
SKIDS			
IAS-SKID-0120	1	CHEMICAL INJECTION SKID	1
ICA-PKG-0100	1	PLANT/INSTRUMENT AIR PACKAGE	1
ICI-SKID-0100	1	PHOSPHATE INJECTION SKID	1
ICI-SKID-0120	1	AMMONIA INJECTION SKID	1
ICI-SKID-0300	1	WSAC SOD, HYPOCHLORITE INJECT SKID	1
ICI-SKID-0310	1	WSAC ACID INJECTION SKID	1
ICI-SKID-0320	1	WSAC SCALE CORROSION INHIBITOR	1
IDW-PKG-0100	1	DEMINERALIZER PACKAGE (RENTED)	1
IHR-SKID-0100	1	NITROGEN SKID	1

EQUIPMENT LIST			
ITEM NO.	AREA	EQUIPMENT DESCRIPTION	QTY.
STACK			
IAS-STK-0100	1	AUX. BOILER STACK	1
FILTERS & STRAINERS			
IFW-STR-0100A/B	1	BFW PUMP STRAINERS	2
IHR-FLT-0100	1	HTF SIDESTREAM FILTER	1
IUL-FLT-0100	1	HTF SYSTEM VENT CARBON FILTER	1
SUMPS			
IBB-SUMP-0100	1	BLOWDOWN SUMP	1
IWW-SUMP-0100	1	OIL/WATER SUMP	1
IWW-SUMP-0200	1	CLEAN WATER SUMP	1
GENERATOR			
IDG-G-0100	1	DIESEL STANDBY GENERATOR	1
IST-TRB-0100	1	STEAM TURBINE GENERATOR	1
SAMPLE PANELS			
IAS-HX-0122	1	AUX. BOILER SAMPLE COOLER (NOT SHN.)	1
ISP-SPNL-0100	1	STEAM/WATER SAMPLE PANEL	1
TANKS & VESSELS			
IAS-SEP-0100	1	SEAL STEAM SEPARATOR	1
IAS-V-0100	1	AUX. BOILER BLOWDOWN DRUM	1
IBB-TK-0100	1	ATMOSPHERIC DRAINS TANK	1
IBB-V-0100	1	CONTINUOUS BLOWDOWN DRUM	1
IBB-V-0200	1	INTERMITTENT BLOWDOWN DRUM	1
IBS-SEP-0100	1	MOISTURE SEPARATOR	1
ICA-V-0100	1	AIR RECEIVER	1
ICC-TK-0100	1	CLOSED COOLING WATER EXP. TANK	1
ICO-TK-0100	1	CONDENSATE TANK	1
ICO-TK-0200	1	STEAM DUCT DRAINS TANK	1
IDG-TK-0100	1	DIESEL STORAGE TANK	1
IDW-TK-0100	1	DEMIN. WATER TANK	1
IHR-DRUM-1100/2100	1	HP STEAM DRUM	2
IHR-TK-0100	1	HTF EXPANSION VESSEL	1
IHR-TK-0400	1	SGS HTF PSV'S DISCH. VESSEL	1
IPW-V-0100	1	POTABLE WATER PRESSURE TANK	1
IUL-TK-0100	1	ULLAGE VESSEL #1	1
IUL-TK-0200	1	ULLAGE VESSEL #2	1
IUL-TK-0300	1	ULLAGE DRAIN VESSEL	1
IUL-TK-0400	1	RECLAMATION FLASH VESSEL	1
IWW-OVS-0100	1	OIL/WATER SEPARATOR	1

H.P.F.S.
EL. 383'-7"

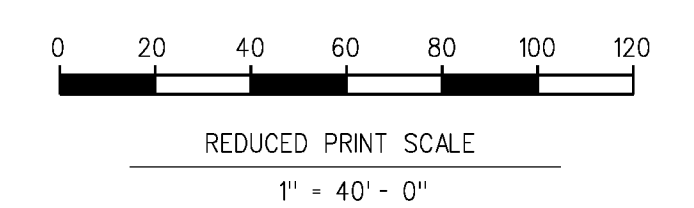

REV	DATE	REVISION DESCRIPTION	BY	CHK	APPV	REFERENCE DWG NUMBER	REFERENCE DRAWINGS
A	02-15-11	ISSUED FOR INTERNAL REVIEW	RK	HB	RM	A4PA-0-PP-5-01	OVERALL SITE PLOT PLAN
1	03-31-11	ISSUED FOR DESIGN	RK	HB	RM		
2	10-17-11	UPDATED PLOT PLAN	RK	HB	RM		

FLUOR

NOTICE: THIS DRAWING HAS NOT BEEN PUBLISHED AND IS THE SOLE PROPERTY OF FLUOR AND IS LENT TO THE BORROWER FOR THEIR CONFIDENTIAL USE ONLY. AND IN CONSIDERATION OF THE LOAN OF THIS DRAWING, THE BORROWER PROMISES AND AGREES TO RETURN IT UPON REQUEST AND AGREES THAT IT WILL NOT BE REPRODUCED, COPIED, LENT OR OTHERWISE DISPOSED OF DIRECTLY OR INDIRECTLY, NOR USED FOR ANY PURPOSE OTHER THAN THAT FOR WHICH IT IS FURNISHED.

RESPONSIBLE ENGINEER

CONTRACT: AFA
DRAWING BY: R. KYLE
DESIGNED BY: R. KYLE
CHECKED BY: H. BERGE
SUPERVISOR: R. MANNING
LEAD ENGR/SPEC. ART: P.M.T.O.
CLIENT: M. ROJAS

APP DATE: 02-15-2011
APP DATE: 02-15-2011
APP DATE: 02-15-2011

SCALE: 1"=40'

DRAWING NUMBER: A4PA-1-PP-5-01

REV: 2

Genesis Solar Energy Project
Riverside County, California

PLOT PLAN UNIT 1
POWER BLOCK

CAD FILE NAME: A4PA1-PP-5-01

APPAIP501.DWG



Extend Cover North

