



TETRA TECH EC, INC.

DOCKET

11-AFC-3

DATE FEB 08 2012

RECD. FEB 09 2012

February 8, 2012

California Energy Commission
Docket No. 11-AFC-3
1516 9th St.
Sacramento, CA 95814

**Subject: Cogentrix Quail Brush Generation Project – Docket Number 11-AFC-3,
Supplement 2 to the AFC**

Docket Clerk:

Pursuant to the provisions of Title 20, California Code of Regulation, Quail Brush Genco, LLC, a wholly owned subsidiary of Cogentrix Energy, LLC, hereby submits *Supplement 2 to the AFC for the Genesis Solar Energy Project*. The Quail Brush generation Project is a 100 megawatt natural gas fired electric generation peaking facility to be located in the City of San Diego, California.

This Supplement was prepared to describe a change to the proposed Project generation tie line (gen tie) from the 230 kilovolt (kV) gen tie proposed in the original Application for Certification (AFC) docketed on August 29, 2011, to the now-proposed 138kV gen tie that will interconnect at San Diego Gas and Electric's Carlton Hills Substation, located approximately 1 mile east of the plant site. It also addresses the proposed laydown area. The 138kV gen tie will not require the construction of a switchyard. This Supplement provides the additional information staff will require to prepare the preliminary staff assessment, and it covers all issue areas addressed in the original AFC.

If you have any questions regarding this submittal, please contact Rick Neff at (704) 525-3800 or me at (303) 980-3653.

Sincerely,

Constance Farmer
Project Manager/Tetra Tech

cc: Eric Solorio/CEC Project Manager

COGENTRIX QUAIL BRUSH GENERATION PROJECT



Supplement 2 to the
Application for Certification

11-AFC-3

February 2012

QUAIL BRUSH GENCO, LLC

TABLE OF CONTENTS

	PAGE
1.0 INTRODUCTION.....	1-1
1.1 DESCRIPTION OF PROPOSED CHANGE TO THE GEN TIE.....	1-1
1.2 RATIONALE FOR THE PROPOSED GEN TIE CHANGE.....	1-2
2.0 PROJECT DESCRIPTION.....	2-1
2.1 GEN TIE DESCRIPTION.....	2-1
2.1.1 Proposed Gen Tie.....	2-1
2.2 GEN TIE ALTERNATIVES.....	2-2
2.3 OVERHEAD GEN TIE CHARACTERISTICS.....	2-3
2.3.1 Transmission System Impacts.....	2-4
2.3.2 Transmission System Required Upgrades.....	2-5
2.3.3 SDG&E Transmission System.....	2-5
2.3.4 Southern California Edison (SCE) Transmission System.....	2-5
2.3.5 Reliability System.....	2-5
2.3.6 Required Interconnection Facilities.....	2-6
2.3.7 Transmission Interconnection Safety and Nuisances.....	2-6
2.4 ONSITE 138KV PLANT SWITCHYARD PROJECT DESCRIPTION.....	2-17
2.5 GEN TIE CONSTRUCTION.....	2-17
2.6 TEMPORARY CONSTRUCTION LAYDOWN AREA DESCRIPTION.....	2-17
3.0 PROPOSED PROJECT AND ALTERNATIVES.....	3-1
3.1 COMPARISON OF PROPOSED PROJECT AND ALTERNATIVES.....	3-1
3.1.1 Proposed 138kV Gen Tie.....	3-1
3.1.2 Alternative 1 138kV Gen Tie.....	3-2
3.1.3 Alternative 2 138kV Gen Tie.....	3-5
3.1.4 Alternative 3 138kV Gen Tie.....	3-5
3.2 AFC ALTERNATIVES.....	3-6
3.2.1 AFC Project Alternative A.....	3-6
3.2.2 AFC Project Alternative B.....	3-7
3.2.3 AFC Project Alternative C.....	3-8
3.3 COMPARISON OF THE PROJECT WITH THE PROPOSED 138KV GEN TIE TO THE PROJECT ORIGINALLY PROPOSED WITH THE 230KV GEN TIE.....	3-9
3.4 COMPARISON OF ENGINEERING, ECONOMIC, AND ENVIRONMENTAL MERITS OF FEASIBLE ALTERNATIVES TO THE PROJECT.....	3-10
4.0 ENVIRONMENTAL INFORMATION.....	4-1
4.1 CULTURAL RESOURCES.....	4-1
4.2 LAND USE.....	4-1
4.3 NOISE.....	4-2
4.4 TRAFFIC AND TRANSPORTATION.....	4-2
4.5 VISUAL RESOURCES.....	4-2
4.6 SOCIOECONOMICS.....	4-3
4.7 AIR QUALITY.....	4-3
4.8 PUBLIC HEALTH.....	4-3
4.9 HAZARDOUS MATERIALS HANDLING.....	4-3
4.10 WORKER HEALTH AND SAFETY.....	4-3
4.11 WASTE MANAGEMENT.....	4-3
4.12 BIOLOGICAL RESOURCES.....	4-3
4.13 WATER RESOURCES.....	4-4

TABLE OF CONTENTS (Continued)

	PAGE
4.14 AGRICULTURE AND SOILS	4-4
4.15 PALEONTOLOGICAL RESOURCES	4-4
4.16 GEOLOGICAL HAZARDS AND RESOURCES	4-4
4.17 CUMULATIVE IMPACTS	4-4
5.0 CONCLUSION	5-1

TABLES

Table 2.3-1 Conductor Sags and Tensions for 477 kcmil ACSS (Hawk)	2-4
Table 2.3-2 Ground Clearance (Reference: RUS BULLETIN 1724E-200)	2-7
Table 2.3-3 ROW Width (Reference: RUS BULLETIN 1724E-200)	2-7
Table 2.3-4 Calculation of Electric Field at Ground	2-9
Table 2.3-5 Calculation of Magnetic Field at 1 Meter Above Ground	2-11
Table 2.3-6 Calculation of Audible Noise at 1.5 Meters Above Ground	2-13
Table 3.1-1 Comparison of the Proposed Project and Alternatives	3-3
Table 3.2-2 Comparison of 230kV Project Impacts and 138kV Project Impacts	3-9

FIGURES

Figure 1.1-1	Project Layout
Figure 2.3-1	Pole Arrangement
Figure 2.3-2	Pole Arrangement
Figure 2.3-3	Pole Arrangement
Figure 4.5-1	Line-of-Sight Analysis Observer Point 1
Figure 4.5-2	Line-of-Sight Analysis Observer Point 2
Figure 4.5-3	Line-of-Sight Analysis Observer Point 3
Figure 4.5-4	Line-of-Sight Analysis Observer Point 4

ATTACHMENTS

Attachment A	October 18, 2011 Letter from CAISO
Attachment B	January 17, 2012 Addendum to the Cluster Phase II Interconnection Study Report
Attachment C	Generator Interconnection Procedures: Deliverability Requirements for Clusters 1-4 Cluster 1 and 2 Deliverability Analysis without Expensive and Long-Lead Network Upgrades

1.0 INTRODUCTION

On August 25, 2011, Quail Brush Genco, LLC (Applicant) docketed with the California Energy Commission an Application for Certification (AFC) 11-AFC-03 for its proposed Quail Brush Generation Project (Project). A Supplement to the AFC was docketed with the CEC on October 24, 2011. The Commission determined that the AFC was data adequate on November 16, 2011.

This Supplement to the AFC (Supplement) provides information regarding proposed changes to the Project, including the 138kV generation tie line (gen tie) from the project site to the Carlton Hills Substation (including ancillary facilities), and a revised laydown area for the Project, as shown on Figure 1.1-1. This document contains a project description and an analysis of the potential environmental impacts that may result from the implementation of these two new components.

1.1 DESCRIPTION OF PROPOSED CHANGE TO THE GEN TIE

The AFC proposed a nominal 100 megawatt (MW) intermediate/peaking load facility using natural gas-fired reciprocating engine technology. The proposed Project, as described in the AFC, included the power generation facility located on a 21.6-acre site, a natural gas pipeline, and a 230kV generation tie line (gen tie) and its ancillary facilities (utility switchyard and access roads). For the purposes of this supplement, gen tie refers to the Project interconnection transmission line and its ancillary facilities such as access roads. The 230kV gen tie included the following:

- An onsite (at the power plant) 230kV facility switchyard including switchgear and the main voltage step-up transformer, switchgear, circuit breakers and disconnects;
- An approximately one-mile long 230kV single-circuit gen tie between the Project and the anticipated Point of Interconnection (POI) to the existing San Diego Gas & Electric (SDG&E) Miguel to Mission 230kV transmission line situated northwest of the plant site;
- A new SDG&E 230kV utility switchyard at the POI configured as a line-break of the existing SDG&E 230kV transmission line that would have included include circuit breakers and disconnects; and
- An approximately one-mile long paved access road to access the new SDG&E 230kV utility switchyard and the poles along the 230kV gen tie.

This Supplement proposes the same power generation facility on the same site with the same natural gas line as that proposed in the AFC, but with a new 138kV gen tie and ancillary facilities instead of the 230kV gen tie and ancillary facilities. The 138kV gen tie includes the following:

- An onsite 138kV facility switchyard including switchgear and the main voltage step-up transformer, switchgear, circuit breakers and disconnects, which would replace the 230kV switchyard facility described on the AFC;
- Approximately 6,850 feet of 138kV single-circuit gen tie, adjacent to the existing SDG&E 138kV transmission line, between the Project and the newly proposed POI at the existing SDG&E 138kV Carlton Hills Substation; and

- Approximately 1,382 feet of new gen tie access roads and spur roads to be constructed off of the existing SDG&E transmission access road that runs along the existing 138kV transmission line.

Unlike the 230kV gen tie described in the AFC, the 138kV gen tie connects to an existing SDG&E utility substation. The 138kV gen tie does not require the construction of a new utility switchyard, the construction of an additional 230kV overhead line or 230kV loop, thus resulting in fewer environmental impacts, lower interconnection and upgrade costs, and a shorter completion time than the original POI. The 138kV gen tie will run parallel to the existing SDG&E 138kV transmission line for approximately 5,400 feet and will utilize the existing access road with spurs to the new tower locations for construction and maintenance purposes. Approximately 1,382 feet of new gen tie access road would be constructed where there are no existing access roads.

Like the 230kV gen tie, the 138kV gen tie would be arrayed in a single-circuit configuration, supported by steel structures. The overhead line conductor type that is proposed for the 138kV Transmission System is a 477 thousand circular mil (kcmil) Aluminum Conductor, Steel Supported (ACSS) Cable (Hawk). This conductor is more than sufficient for the 138kV gen tie. Due to the lower voltage of the 138kV gen tie, a range of conductors is not necessary to address corona issues.

1.2 RATIONALE FOR THE PROPOSED GEN TIE CHANGE

The proposed Project will be operated as a peaking station and will enhance the reliability and availability of SDG&E's 138kV transmission system in the service area by supporting intermittent solar and wind generation.

The California Independent System Operator (CAISO)/SDG&E issued the Project Cluster 2 – Phase II Interconnection Study on August 24, 2011 (Phase II Interconnection Study) based on the POI being at a new 230kV utility switchyard looping into SDG&E's Mission-Miguel 230kV transmission line (TL23023), as proposed in the AFC. A redacted version of the Phase II Interconnection Study was docketed with the CEC on October 13, 2011. The Phase II Interconnection Study stated that SDG&E will require up to 60 months to complete the construction of the new interconnection facility so that the Project can tie into the transmission grid. The 60-month period would have impacted the Project commercial operation date of mid-2014. Furthermore, the Phase II Interconnection Study indicated that the new interconnection facility was associated with a high cost impact for SDG&E ratepayers.

The Applicant entered into an Engineering and Procurement Agreement with SDG&E to address specific details of the interconnection facility and options to improve the schedule and lower the cost estimate. A team from Cogentrix Energy, LLC, Tetra Tech, and SDG&E visited the site vicinity on September 22, 2011, to look at the proposed locations for the SDG&E interconnection facility and loop-in requirements of the Mission-Miguel 230kV transmission line (TL23023).

Upon completion of the field visit, subsequent examination of the local transmission system was undertaken including further review of the anticipated Project power flows, the capacity and location of existing transmission lines, and the physical distances of the Project gen tie to the existing transmission lines in the Project vicinity, specifically the existing 138kV circuit located

closer to the Project site. Primary consideration in the analysis was given to the ability of the existing SDG&E transmission system, to accept the anticipated Project output. Additional aspects considered included environmental effects of building and maintaining the new gen tie, right-of-way (ROW) acquisition and modification(s), engineering requirements, and Project costs. Alternative interconnection options were identified after analyses of these data and review of the SDG&E transmission system maps and one-line diagrams. Based upon these alternatives, the proposed transmission line alignment, interconnection configuration, and construction techniques were selected and it was determined that interconnection at the 138kV Carlton Hills Substation is now the preferred POI. The new preferred POI would eliminate the need for the new 230kV utility switchyard and loop extension, thus resulting in fewer environmental impacts, lower interconnection and upgrade costs, and a shorter completion time than the original POI.

On October 18, 2011, Cogentrix Energy, LLC submitted a request to the CAISO requesting a change to the POI for the Project from the Mission-Miguel 230kV transmission line to the existing SDG&E 138kV Carlton Hills Substation. The CAISO on November 22, 2012, notified the applicant that the requested change in the POI is not a material modification and that an addendum to the Project's Phase II Interconnection Study report reflecting such change would be issued upon confirmation of the applicant's desire to pursue such POI (Attachment A). This change will result in fewer environmental impacts than the originally proposed Project, substantially lower interconnection and upgrade costs to the SDG&E ratepayers, and a much shorter completion time estimated at no more than 12 months compared to the 60 months estimated as required for the original POI. Because CAISO has accepted the Carlton Hills Substation POI, the original POI of the SDG&E Mission-Miguel 230kV transmission line, is no longer an option for the Project.

On January 17, 2011, CAISO/SDG&E issued an Addendum to the Cluster Phase II Interconnection Study Report (Phase II Interconnection Addendum) to reflect a change in the POI from the original POI of the SDG&E Mission-Miguel 230kV transmission line to the 138kV bus of SDG&E's Carlton Hills Substation. A redacted version of the Phase II Interconnection Addendum is being submitted along with this Supplement (Attachment B). The change of POI location will allow the gen tie to follow an existing transmission line corridor and will provide extensive savings in cost to the utility (and by extension, rate-payers), as follows:

- Eliminates the expense of a new interconnection switchyard facility and will reduce overall time to complete interconnection facilities from 60 months to less than 12 months;
- Eliminates the need to disturb existing 230kV transmission lines (no loop-in required);
- Potential elimination of several delivery network upgrades at the 500kV (Southern California Edison [SCE]) level.

As stated in the technical bulletin revised February 2, 2012 and technical report dated January 31, 2012 (Attachment C), another addendum to the Project Phase II Study report, which eliminates the Southern California Edison system delivery network upgrades, is expected to be issued in the near future and will be provided when available.

The Project including the proposed 138kV gen tie will satisfy the project objectives in the AFC and will enhance the reliability and availability of SDG&E's 138kV transmission system. The change from the 230kV gen tie to the 138kV gen tie will not negatively impact the SDG&E 230kV transmission system with the completion of each of the reliability and delivery network upgrades for the SDG&E transmission system identified in the Phase II Interconnection Addendum.

2.0 PROJECT DESCRIPTION

2.1 GEN TIE DESCRIPTION

The Project site was selected, in part, for its proximity to existing transmission and natural gas lines. SDG&E has several transmission lines near the proposed power plant. An existing transmission corridor is located approximately 3,500 feet northwest of the proposed site with several lines running in a southwest-northeast direction. This transmission corridor contains two separate, parallel 230kV transmission lines (TL23022 & TL23023), two separate, parallel 138kV transmission lines (TL13821 & TL13822), and one 69kV transmission line. The two separate, parallel 138kV transmission lines (TL13821 & TL13822) turn east and pass approximately 2,000 feet north of the proposed plant site in an east-west direction. These 138kV transmission lines terminate at the existing SDG&E Carlton Hills Substation located approximately 1 mile east-northeast of the plant site.

The Project with the 230kV gen tie proposed in the AFC would have connected into SDG&E's Mission-Miguel 230kV transmission line in the transmission corridor that is located northwest of the proposed power plant site. In this Supplement, the Applicant proposes to change the POI to the existing SDG&E Carlton Hills Substation and propose a new 138kV gen tie for the Project. The proposed 138kV gen tie ROW will head north northeast from the proposed power generation site to the south side of the existing east-west SDG&E 138kV transmission line corridor, where it will parallel the existing 138kV transmission line to the east until it reaches the existing Carlton Hills Substation. The proposed 138kV gen tie will require modifications to the existing SDG&E 138kV Carlton Hills Substation. SDG&E will expand the existing 138kV air insulated buswork as required, to accommodate the Project's 138kV gen tie within the existing fence line of the SDG&E Carlton Hills Substation.

The Applicant proposes three alternative alignments to the proposed 138kV gen tie, as described below and shown in Figure 1.1-1. The 230kV gen tie described previously in the AFC, including the SDG&E 230kV utility switchyard described in Section 2.5 of the AFC, will no longer be required for the Project as a result of the proposed interconnection using the 138kV gen tie.

The proposed Project including the 138kV gen tie will connect to the SDG&E 138kV transmission system at the Carlton Hills Substation, which is located approximately 1 mile east northeast of the plant site. The exact alignment of the proposed gen tie and three alternatives from the plant site to the SDG&E Carlton Hills Substation would be determined during easement negotiations with landowners and after preparation of more detailed engineering design.

2.1.1 Proposed Gen Tie

The proposed 138kV gen tie will start at the dead-end structure inside the plant switchyard on the north side of the power plant. The gen tie will then proceed north, east of Sycamore Landfill Road (a private road) for approximately 1,350 feet, and then travel northeast for approximately 900 feet, where it will turn eastward for approximately 4,600 feet (south of and parallel to the existing 138kV transmission lines) to the SDG&E 138kV Carlton Hills Substation. The Applicant intends to commence interconnection facilities review with SDG&E transmission department personnel pursuant to an engineering support agreement entered into with SDG&E.

The total length of the proposed 138kV gen tie between the plant site and the Carlton Hills Substation is approximately 6,850 feet. The 138kV gen tie will be installed on steel poles and

will have a ruling span of about 450 to 600 feet. The location and width of the Proposed 138kV gen tie will consider, as required, 138kV line clearances and will address operational and maintenance criteria required by the California Public Utilities Commission (CPUC) General Order No. 95 (GO-95). In addition, the new gen tie will conform to the recent “Electromagnetic Field (EMF) Guidelines for Electrical Facilities” prepared in response to the CPUC Decision 06-01-042.

2.2 GEN TIE ALTERNATIVES

Three alternatives to the proposed 138kV gen tie are also being considered (Figure 1.1-1) as follows:

- **Alternative 1 138kV Gen Tie.** The gen tie would start at the dead-end structure inside the plant switchyard on the north side of the plant. The gen tie ROW would then proceed east for approximately 3,000 feet, and then travel east northeast approximately 2,200 feet (south of and parallel to the existing 138kV transmission lines) to the Carlton Hills Substation. The total length of the Alternative 1 138kV gen tie between the plant site and the substation is approximately one mile.
- **Alternative 2 138kV Gen Tie.** The gen tie will start at the dead-end structure inside the plant switchyard on the north side of the plant. The gen tie ROW would then proceed north, east of Sycamore Landfill Road for approximately 1,350 feet, then travel northeast for approximately 900 feet, where it will turn eastward for approximately 2,300 feet (south of and parallel to the existing 138kV transmission lines), then cross under (from south to north) the existing SDG&E 138kV transmission lines. The gen tie will then travel east northeast for approximately 2,200 feet (north of and parallel to the existing 138kV transmission lines) to the Carlton Hills Substation. The total length of Alternative 2 138kV gen tie between the power plant site and the substation is approximately 6,750 feet.
- **Alternative 3 138kV Gen Tie.** This alternative would start at the dead-end structure inside the plant switchyard on the north side of the power plant. The gen tie will then proceed north, east of Sycamore Landfill Road (a private road) for approximately 2,050 feet, and then turn eastward (south of and parallel to the existing 138kV transmission lines) to the SDG&E 138kV Carlton Hills Substation. The total length of Alternate 3 138kV gen tie between the power plant site and the substation is approximately 7,800 feet.

Conceptual engineering of the proposed 138kV gen tie will be performed by the Applicant based on the results of the Phase II Interconnection Study being supplemented by CAISO/SDG&E for the new POI, and through technical engineering support provided by SDG&E.

As the SDG&E 230kV utility switchyard will not be required for the 138kV gen tie, neither will the one-mile long paved access road to the switchyard. The proposed 138kV gen tie will be located adjacent to the existing SDG&E 138kV transmission line and the existing road to access this line will be used to construct the Project gen tie. Spur roads will be constructed off of the access road to access each individual pole location. Approximately 1,382 feet of new gen tie access road would be constructed where there are no existing access roads. The change to the 138kV gen tie will result in a lower environmental impact because the utility switchyard and one-mile long paved access road will not be constructed. Table 3.2-2 contains the disturbance associated with the original Project as presented in the AFC compared to the disturbance associated with the proposed Project.

2.3 OVERHEAD GEN TIE CHARACTERISTICS

The proposed 138kV gen tie will be designed to carry the full output of the plant at 138kV. The gen tie will be arrayed in a single-circuit configuration, supported by steel structures placed at appropriate intervals. The overhead line conductor type (Table 2.3-1) to be considered will be 477 thousand circular mil (kcmil) Aluminum Conductor, Steel Supported (ACSS) Cable (Hawk).

Selection of the appropriate conductor depends upon the peak power to be transmitted through the gen tie. The Project is capable of generating 100 MW of power. Assuming a power factor equal to 0.90 (as required by the PPA with SDG&E), nominal current of single circuit 138kV line will be 465 amps. The current ampacity rating for the 477 kcmil ACSS (Hawk) conductor is 1188.

This rating exceeds gen tie current requirements by 250 percent. Considering all ampacity de-rating factors; solar heat absorption and conductor heat due to current and all site condition factors (such as maximum ambient temperature, azimuths of sun and line), 477 kcmil ACSS (Hawk) conductors are more than sufficient with regards to ampacity.

The selection of the steel pole designs for the proposed 138kV gen tie will be determined by the exact ROW location and accommodation of changes of direction in the gen tie. The dead-end poles, heavy-angle poles, and tangent type poles would be used as needed.

The structure types used for the gen tie will be single circuit steel mono-pole design with 138kV circuit. Steel tangent and dead-end pole outlines and geometry are shown in Figures 2.3-1, 2.3-2, and 2.3-3. The insulators used for the tangent and small angle structures (WPI-type) will be 138kV 3.5-inch polymer posts with a cantilever breaking strength of 3,410 pounds. The insulators used for all dead-end structures (Y and YPI-type) will be 138kV silicone rubber strains with a tensile capacity of 25,000 pounds. Insulators for jumpers on dead-end structures (YPI-type) will be 138kV polymer type posts. For all insulator applications, mechanical loading shall not exceed 50 percent of the insulator's strength capacity under GO 95 loading conditions.

Referring to Table 2.3-1, the maximum sag for 477 kcmil ACSS (Hawk) conductor in a 1,250-foot span at 270° Fahrenheit (F) is 60.96 feet.

The proposed 138kV gen tie will exit the plant switchyard in a slack span configuration from the dead-end structures (approximately 60 feet tall) on the north side of the plant site. From that structure, the gen tie will travel north then east with an average span of 400 to 600 feet. Depending on the final routing of the gen tie, heavy-angle structures will be placed as required for a distance of approximately 6,850 feet to accommodate changes in direction of the line. The remaining new pole structures will be tangent-type design and will be spaced based on engineering criteria. The new pole structures will be approximately 65 to 85 feet tall. See the structure framing drawings for each of the (3) steel pole types (Figures 2.3-1, 2.3-2, and 2.3-3) that are to be utilized. A 477 kcmil ACSS (Hawk) conductor has been chosen and has sufficient capacity to carry required current.

Table 2.3-1 Conductor Sags and Tensions for 477 kcmil ACSS (Hawk)

Span Length in Feet	Conditions	Tension in Pounds
300 to 400-foot span		
GO-95 Light	I	4,946
NESC High Wind	I	4,999
0° Final	F	5,138 (1.98')
60° Hot	F	3,657 (2.79')
120° Hot	F	2,276 (4.48')
212° Hot	F	1,768 (5.78')
270° Hot	F	1,536 (6.65')
400-500 ft span		
GO-95 Light	I	4,579
NESC High Wind	I	4,999
0° Final	F	4,616 (4.03')
60° Hot	F	3,100 (6.01')
120° Hot	F	2,261 (8.25')
212° Hot	F	1,879 (9.94')
270° Hot	F	1,699 (11.00')
500-750 ft span		
GO-95 Light	I	4,241
NESC High Wind	I	5,000
0° Final	F	3,918 (7.25')
60° Hot	F	2,794 (10.18')
120° Hot	F	2,252 (12.66')
212° Hot	F	1,952 (14.62')
270° Hot	F	1,805 (15.83')
1,250 ft span		
GO-95 Light	I	3,271
NESC High Wind	I	5,000
0° Final	F	2,482 (50.70')
60° Hot	F	2,335 (53.98')
120° Hot	F	2,228 (56.69')
212° Hot	F	2,133 (59.33')
270° Hot	F	2,078 (60.96')

Notes:

** tension data extrapolated

Acronyms and Abbreviations:

ACSR – Aluminum Conductor Steel Reinforced Cable

F – Final

ft - feet

GO-95 California General Order No. 95

I – Initial

kcmil – thousand circular mil

lbs pounds

NESC High Wind 18.5 pounds per square foot

SDC - Self Damping Conductor

2.3.1 Transmission System Impacts

The Project’s Phase II Interconnection Study performed by CAISO/SDG&E evaluated the impact of the plant power output on the SDG&E transmission system under steady state and transient conditions. As discussed above in section 1.2, the Phase II Interconnection Addendum was issued by CAISO on January 17, 2012. The Addendum was issued to reflect the change in POI to the SDG&E 138kV Carlton Hills Substation. There exists the possibility for adverse

impacts to the transmission system that will require network upgrades to mitigate potential problems. These upgrades are summarized in Section 2.3.4. The following adverse impacts were identified in the Phase II Interconnection Study:

- Multiple Category B overloads in SDG&E transmission system
- Multiple Category B & C overloads in SCE transmission system

These deficiencies can be corrected by physical upgrades to the delivery network.

- Steady-state thermal overload of Bernardo-Felicita Tap 69kV line

This deficiency can be corrected by reliability upgrades to the delivery network.

2.3.2 Transmission System Required Upgrades

Required upgrades were identified in the Phase II Interconnection Study (and unchanged in the Phase II Interconnection Addendum) to mitigate any adverse impacts to the transmission system from the increase in power flow from the Project. These upgrades can be performed concurrently, so the total time to construct should not exceed the maximum estimated time of 84 months.

2.3.3 SDG&E Transmission System

- Reconductor the Escondido-Palomar Energy 230kV lines #1 & #2
- Reconductor the Friars-Doublet Tap 138kV line

These upgrades will require 12 months to complete.

2.3.4 Southern California Edison (SCE) Transmission System

The following upgrades are required in the SCE system:

- Loop the Lugo-Mojave 500kV line into Pisgah Substation
- Add series capacitor banks on the Nipton-Pisgah & Mojave-Pisgah 500kV lines
- Add new Red-Bluff-Valley 500kV line
- Add new Colorado River-Red-Bluff No.3 500kV line

These upgrades would require 84 months to complete. These resources are not required in order to transmit power to SDG&E transmission system (customer), but are required by resource allocation studies. As stated in the technical bulletin revised February 2, 2012 and technical report dated January 31, 2012 (Attachment C), another addendum to the Project Phase II Interconnection Study, which would eliminate the Southern California Edison system network upgrades, is expected to be issued in the near future and will be provided when available.

2.3.5 Reliability System

The following upgrades are required to bolster system reliability:

- Implement SPS to protect the Bernardo-Felicita Tap 69kV line for N-2 contingencies
- Implement SPS to protect the Mission-Old Town 230kV line for N-2 contingencies

These upgrades will require 12 months to complete.

2.3.6 Required Interconnection Facilities

The original POI into the SDG&E 230kV transmission system would have required the construction of a new SDG&E utility substation to loop-in existing 230kV lines to accommodate the output of the plant. The revised POI will be the existing SDG&E 138kV Carlton Hills Substation. In order to connect the Project's power generation facility to the 138kV transmission system, a high voltage circuit breaker bay needs to be assigned/constructed in the existing substation to accommodate the new, incoming 138kV gen tie along with a dead end structure. The revised POI will reduce construction time of required interconnection facilities from 60 months (original time to construct new utility substation) to less than 12 months (additions to existing substation).

2.3.7 Transmission Interconnection Safety and Nuisances

This section discusses safety and nuisance issues associated with the new POI of the proposed Project to the SDG&E electrical grid. Information in this section reflects the POI change in voltage from 230kV to 138kV. The change in the project from a 230kV gen tie to a 138kV gen tie required additional modeling of safety and nuisance factors to determine any potential impacts that may result from the change in the Project. This section presents the findings of this modeling for the 138kV gen tie. Construction and operation of the proposed overhead gen tie will be undertaken in a manner that ensures the safety of the public, as well as maintenance and ROW crews, while supplying power with minimal electrical interference.

2.3.7.1 Electrical Clearances

Typical high-voltage overhead transmission lines are composed of bare conductors connected to supporting structures by means of porcelain, glass, or polymer insulators. The air surrounding the energized conductor acts as the insulating medium. Maintaining sufficient clearances, or air space, around the conductors to protect the public and utility workers is paramount to safe operation of the line.

The proposed 138kV gen tie will be installed overhead and will be approximately 6,850 feet in length, and will be constructed with bare overhead conductors connected to supporting structures by means of porcelain, glass, or polymer insulators. The overhead gen tie will be built by the Applicant and owned and operated by SDG&E. The safety clearance required around the conductors is determined by normal operating voltages, conductor temperatures, short-term abnormal voltages, windblown swinging conductors, contamination of the insulators, clearances for workers, and clearances for public safety. Minimum clearances are specified in GO-95 and the National Electrical Safety Code (NESC). Electric utilities, state regulators, and local ordinances may specify additional (more restrictive) clearances.

Gen tie clearances above ground and ROW width for the 138kV gen tie are provided in Tables 2.3-2 and 2.3-3 below.

Table 2.3-2 Ground Clearance (Reference: RUS BULLETIN 1724E-200)

Clearance Description	Clearance Above Ground for 138kV Line Voltage Phase-to-Phase (Nominal) (feet)
Spaces and ways accessible to pedestrians only <i>Note:</i> Areas accessible to pedestrians only are areas where riders on horses or other large animals, vehicles or other mobile units exceeding 8 feet in height are prohibited by regulation or permanent terrain configurations or are not normally encountered or reasonably anticipated. Land subject to highway right-of-way maintenance equipment is not to be considered as being accessible to pedestrians only	30

Table 2.3-3 ROW Width (Reference: RUS BULLETIN 1724E-200)

Clearance Description	Typical ROW Width for 138kV Nominal Line Voltage, Phase to Phase (feet)
ROW width	100-150

Other typical clearances will be specified for the following, as part of the final design:

- Distance between the energized conductors themselves (same line)
- Distance between the energized conductors and the supporting structure (taking into account the length of insulators used and the swing and vibration movement of the conductors)
- Distance between the energized conductors and other power or communication wires on the same supporting structure, or between other power or communication wires above or below the conductors
- Distance from the energized conductors to the ground and features, such as roadways, railroads, driveways, parking lots, navigable waterways, and airports
- Distance from the energized conductors to buildings and signs
- Distance from the energized conductors to other power lines (examples include other parallel lines and line being crossed over)

The proposed Project gen tie will be designed to meet all national, state, and local code clearance requirements. These standards are summarized in the LORS table in Section 2.9 of the AFC and described in more detail in Appendix B, Engineering Design Criteria of the AFC.

2.3.7.2 Electrical Effects

The electrical effects of high-voltage transmission lines fall into two broad categories—corona effects and field effects. Because these effects have the potential to cause a deviation from the normal they are often termed Electromagnetic Interference (EMI):

- Corona is the ionization of the air that occurs at the surface of the energized conductor and suspension hardware due to very high (i.e., when it is above a critical level) electric field strength at points between the high voltage side of the line and ground. The location and extend of corona varies and is dependent on the design, construction techniques and the environment. Besides the power loss associated with corona, corona could result in radio and television reception interference (RI and TVI), audible noise (AN), light, and production of ozone. The key technical parameters affecting corona include: line voltage, line phase configuration, insulating distances, insulating hardware, conductors and configuration of conductor bundles, environmental parameters, and attention to detail during construction.
- Field effects are a direct result of the voltage and current associated with the line. Electric field effects are a direct result of the 60 hertz (Hz) line voltage and the 60 Hz magnetic field effects and are a consequence of the load current. These fields are of interest because they couple into nearby objects. Consequently, levels need to be managed such that the coupling does not produce unintended consequences.

Operating power lines, like the energized components of electrical motors, home wiring, lighting, and all other electrical appliances, produce electric and magnetic fields commonly referred to as the electromagnetic field (EMF). The dominant EMF produced by the alternating current electrical power system in the United States has a frequency of 60 Hz, meaning that the intensity and orientation of the field changes 60 times per second. Consequently, it is essential to ensure electromagnetic compatibility (EMC) with the operating environment.

The 60 Hz power line fields are considered to be extremely low frequency. To place this in context, other common frequencies include: AM radio, which operates up to 1,600,000 Hz (1,600 kilohertz [kHz]); television, 890,000,000 Hz (890 megahertz [MHz]); cellular telephones, 900,000,000 Hz (900 MHz); microwave ovens, 2,450,000,000 Hz (2.4 gigahertz [GHz]); and X-rays, about 1 billion Hz. Higher frequency fields have shorter wavelengths and greater energy in the field. Microwave wavelengths are a few inches long and have enough energy to cause heating in conducting objects. High frequencies, such as x-rays, have enough energy to cause ionization (breaking of atomic or molecular bonds). At the 60 Hz frequency associated with electric power transmission, the electric and magnetic fields have a wavelength of 3,100 miles and have very low energy that does not cause heating or ionization. The 60 Hz fields do not radiate, unlike radio frequency fields.

2.3.7.3 Electric Fields

Electric fields around transmission lines are produced by potential difference (voltage) between an energized conductor and surrounding objects. Electric field strength is directly proportional to the line's voltage; that is, increased voltage produces a stronger electric field. The electric field is inversely proportional to the distance from the conductors, so that the electric field strength declines as the distance from the conductor increases. As the electric field is relative to line voltage which can be considered a "constant", electric field around a transmission line remains practically steady and is not affected by the common daily and seasonal fluctuations in use of electricity by customers. The electric field pattern is however affected by both permanent and temporary objects within the electric field.

The basic unit of measurement for an electric field is V/m – volts per meter. In the case of transmission lines the usual unit of measure is kV/m – thousands of volts per meter. Table 2.3-4 provides a preliminary calculation of the electric field strength for the Project's 138kV gen tie.

Note that calculations were based on a gen tie length of 7,800 feet. Final calculations will be prepared when final design for the gen tie is complete.

Table 2.3-4 Calculation of Electric Field at Ground

Reference: EPRI's Red Book, Section 8.5, Nomogram to calculate Emax.

Introducing involved parameters:

- The minimum distance to ground for any overhead conductor is 30 feet
- The results assume 138kV gen tie is located south of existing lines (TL13821 & TL13822)
- The centerline of the 138kV gen tie is located 25 feet south of the ROW centerline
- The results are calculated at final transmission line pole (prior to overhead lines entering utility substation)

Distance from ROW Centerline (feet)	Electric Field Intensity (E) New Line Contribution (kV/m)	Overall Electric Field Intensity (E) Resultant – 3 x 138kV Lines (kV/m)
-75 (north)	0.0704	0.9029
-70	0.0741	0.6250
-65	0.0776	0.4289
-60	0.0809	0.3117
-55	0.0838	0.2538
-50	0.0860	0.2364
-45	0.0870	0.2440
-40	0.0862	0.2553
-35	0.0829	0.2602
-30	0.0766	0.2570
-25	0.0677	0.2474
-20	0.0625	0.2385
-15	0.0784	0.2490
-10	0.1297	0.2937
-5	0.2178	0.3747
0	0.3451	0.4945
+5	0.5136	0.6556
+10	0.7169	0.8515
+15	0.9301	1.0577
+20	1.1045	1.2254
+25 (centerline of gen tie conductors)	1.1816	1.2960
+30	1.1294	1.2378
+35	0.9700	1.0727
+40	0.7599	0.8573
+45	0.5520	0.6443
+50	0.3755	0.4632
+55	0.2400	0.3233
+60	0.1443	0.2235
+65	0.0857	0.1609
+70	0.0632	0.1349
+75 (south)	0.0660	0.1343

Anticipated electric field "E" levels are well within acceptable margin of 138kV lines.

The highest magnitude of electric field on ground (directly below the centerline of the gen tie) is approximately 1.3 kV/m. The contribution to the existing electric field from the gen tie at 50 feet from that point is approximately 0.07 kV/m which results in a resultant electric field intensity of less than 0.2 kV/m at the southern edge of the gen tie ROW, which is well below the acceptable maximum value (utilized formulas and graphs are taken from EPRI's red book, ROW from RUS Bulletin 1724E-200).

Once the gen tie route is finalized, a final calculation will be performed to determine the actual strength of the electric field along the proposed route.

2.3.7.4 Magnetic Fields

Magnetic fields or EMF around transmission lines are produced by the current flow, measured in terms of amperes, through the conductors. The magnetic field strength is directly proportional to the magnitude of current flow; that is, increased amperes produce a stronger magnetic field, or increased magnetic flux density. The magnetic field is inversely proportional to the distance from the conductors. Thus, like the electric field, the magnetic field strength declines as the distance from the conductor increases. The international unit of measure for magnetic flux density is Tesla (T). In the United States, the more common measure is Gauss (G). For transmission lines, typical magnetic fields are expressed in units of milligauss (mG). The amperes and, therefore, the magnetic field around a transmission line, fluctuate daily and seasonally as the use of electricity varies.

Considerable research has been conducted over the last 30 years on the possible biological effects and human health effects from EMF. This research has produced many studies that offer no uniform conclusions about whether or not long-term exposure to EMF is harmful. In the absence of conclusive or evocative evidence, some states, California in particular, have chosen not to specify maximum acceptable levels of EMF. Instead, these states mandate a program of prudent avoidance whereby EMF exposure to the public would be minimized by encouraging electric utilities to use low-cost techniques to reduce the levels of EMF.

EMF field strengths were calculated using the SESTLC (Transmission Line Parameters and Transmission Line Calculator) software package developed by the Safe Engineering Services & Technologies, LTD (SESTech). SESTLC expresses electric fields (EF) in kV/m and magnetic fields in mG (Table 2.3-5).

The various inputs for the calculations include voltage, current load, current angle, conductor type and spacing, number of subconductors, subconductor bundle symmetry, spatial coordinates of the conductors and shield wire, various labeling parameters, and other specifics. The field level is calculated perpendicular to the line and at mid-span where the overhead line sags closest to the ground (calculation point). The midspan location, therefore, provides the maximum value for the field. The EF and EMF values should be calculated at a level of 3 feet (or 1 meter) above flat terrain.

Table 2.3-5 Calculation of Magnetic Field at 1 Meter Above Ground

Reference: EPRI's Red Book, Section 8.6.

Introducing involved parameters:

- The minimum distance to ground for any overhead conductor is 30 feet
- The results assume 138kV gen tie is located south of existing lines (TL13821 & TL13822)
- The centerline of the 138kV gen tie is located 25 feet south of the ROW centerline
- The results are calculated at final transmission line pole (prior to overhead lines entering utility substation)
- The results assume 138kV gen tie is located south of existing lines (TL13821 & TL13822)
- Spacing between conductors is 6.0 feet
- Current flows for each line are: 142.1A for TL13821; 446.1A for TL13822; 464.6A for gen tie
- The results assume 138kV gen tie is located south of existing lines (TL13821 & TL13822)

Distance from ROW Centerline (feet)	Distance between center of set of conductors (phases) to measuring point at 1 meter above ground (feet)	Magnetic Field Intensity (B) (mG)
-75 (north)	106.66	4.1774
-70	101.96	4.5712
-65	97.29	5.0203
-60	92.66	5.5348
-55	88.07	6.1271
-50	83.52	6.8121
-45	79.03	7.6083
-40	74.61	8.5378
-35	70.26	9.6275
-30	66.00	10.9093
-25	61.86	12.4205
-20	57.85	14.2023
-15	54.00	16.2965
-10	50.36	18.7383
-5	46.97	21.5412
0	43.89	24.6727
+5	41.18	28.0184
+10	38.94	31.3449
+15	37.23	34.2847
+20	36.14	36.3846
+25 (centerline of gen tie conductors)	35.72	37.2400
+30	36.00	36.6653
+35	36.96	34.7866
+40	38.55	31.9777
+45	40.70	28.6951
+50	43.31	25.3302
+55	46.33	22.1435
+60	49.66	19.2701
+65	53.26	16.7562
+70	57.06	14.5948
+75 (south)	61.04	12.7539

While the State of California does not set a statutory limit for electric and magnetic field levels, the CPUC, which regulates electric transmission lines, mandates EMF reduction as a practicable design criterion for new and upgraded electrical facilities. As a result of this mandate, the regulated electric utilities have developed their own design guidelines to reduce EMF at each new facility. In the spring of 2006, a utility workshop culminated in the development of standardized design guidelines. The CEC, which regulates transmission lines to the first POI, requires independent power producers to follow the existing guidelines used by local electric utilities or transmission system owners.

In keeping with the goal of EMF reduction, the interconnection of the proposed Project will be designed and constructed using the principles outlined in the SDG&E publication, *EMF Design Guidelines for Electrical Facilities*. These guidelines explicitly incorporate the directives of the CPUC by developing design procedures compliant with Decision 93-11-013 and General Orders 95, 128, and 131-D. When the gen tie structures, conductors, and alignment are designed according to the SDG&E guidelines, the gen tie will be consistent with the CPUC mandate.

From page 37 of the SDG&E guidelines, the following are the primary techniques for reducing EMF along the line:

1. Increase the pole height for overhead design.
2. Use compact pole-head configuration.
3. Minimize the current on the line.
4. Optimize the configuration of the phases (A, B, C).

The anticipated EMF levels have been calculated for the proposed Project gen tie as preliminarily designed. The CEC requires actual measurements of pre-interconnection background EMF to compare with measurements of post-interconnection EMF levels. If required, the pre- and post-interconnection verification measurements will be made consistent with IEEE guidelines and will provide sample readings of EMF at the edge of the ROW. Additional measurements will be made by request for locations of particular concern.

The highest magnitude of magnetic field at 1 meter above ground (directly below the conductor) is 37.2 mG. The magnetic field at the southern edge of the gen tie ROW is 12.7 mG. The magnetic field at the edge of the ROW is below the acceptable maximum value (utilized formulas are taken from EPRI's red book).

2.3.7.5 Audible Noise

Corona is a function of the voltage of the line, the diameter of the conductor, and the condition of the conductor and suspension hardware and the environment. The electric field gradient is the rate at which the electric field changes and is directly related to the line voltage. The electric field gradient is greatest at the surface of the conductor. Large-diameter conductors and bundles of conductors (a bundle of conductors is equivalent to a conductor of the same diameter as the outer diameter of the bundle) have lower electric field gradients at the conductor surface and, hence, lower corona than smaller conductors, everything else being equal. Irregularities, such as nicks and scrapes on the conductor surface, or sharp edges on suspension hardware, concentrate the electric field at these locations and increase corona at these spots. Similarly, contamination on the conductor surface, such as dust or insects, can

cause irregularities that are a source for corona. Raindrops, snow, fog, and condensation are also sources of irregularities. Corona typically becomes a design concern for transmission lines having voltages of 345kV and above.

It is important that any discussion of EMF and audible noise include the assumptions used to calculate these values and remembering that EMF and audible noise near the power lines vary with regard to line design, line loading, distance from the line, and other factors. Both the electric field and audible noise depend on line voltage, which remains nearly constant for a transmission line during normal operation. A worst-case voltage of 145kV (138kV +5 percent) will be used in the calculations for the proposed 138kV gen tie.

Once the transmission line route is finalized a calculation will be performed to determine the magnitude of audible noise from the 138kV gen tie along the proposed route. The following assumptions in Table 2.3-6 commonly used by utility companies will be adopted for this study:

Table 2.3-6 Calculation of Audible Noise at 1.5 Meters Above Ground

- The line will be considered loaded at 75 percent of forecasted load.
- Magnetic field strength will be calculated at 1-1/2 meters (1.5 m) above ground.
- Resultant magnetic fields are to be utilized.
- All line loadings are assumed balanced.
- Dominant power flow directions will be used.

Distance from ROW Centerline (feet)	Overall Audible Noise Existing 138kV Lines (dBA)	Overall Audible Noise Existing 138kV Lines + Gen Tie (dBA)
-75 (north)	21.94	22.57
-70	21.91	22.49
-65	21.89	22.43
-60	21.91	22.40
-55	21.95	22.40
-50	22.02	22.43
-45	22.12	22.50
-40	22.24	22.59
-35	22.40	22.71
-30	22.58	22.87
-25	22.80	23.05
-20	23.04	23.27
-15	23.30	23.51
-10	23.59	23.78
-5	23.90	24.06
0	24.22	24.37
+5	24.54	24.67
+10	24.84	24.96
+15	25.10	25.20
+20	25.27	25.37
+25 (centerline of gen tie conductors)	25.33	25.42
+30	25.27	25.36
+35	25.10	25.19
+40	24.83	24.93
+45	24.51	24.61
+50	24.16	24.26

Distance from ROW Centerline (feet)	Overall Audible Noise Existing 138kV Lines (dBA)	Overall Audible Noise Existing 138kV Lines + Gen Tie (dBA)
+55	23.79	23.90
+60	23.43	23.55
+65	23.08	23.20
+70	22.75	22.87
+75 (south)	22.43	22.56

The highest magnitude of audible noise at 1.5 meters above ground (directly below the conductors) is approximately 25.4 dBA. The level of audible noise at the southern edge of the gen tie ROW is approximately 22.6 dBA. These levels are only slightly higher than current audible noise from existing 138kV lines (about +0.1 dBA).

Currently, the region immediately surrounding the power plant site is undeveloped land and the majority of noise sensitive areas are located to the east in the City of Santee. There is significant terrain shielding that will help block sound propagating to the residential areas. Given the extended separation distances and terrain shielding, operation of the electrical transmission line and switchyard are not expected to result in an adverse noise impact. Transmission line and switchyard audible noise are further discussed in AFC Section 4.3.4.3.

2.3.7.6 Induced Current and Voltages

A conducting object, such as a vehicle or person located within an electric field, will have induced voltages and currents. The strength of the induced current will depend on the electric field strength, the location, size and shape of the conducting object, and the object-to-ground resistance. Examples of measured induced currents in a 1 kV/m electric field are about 0.016 milliamps (mA) for a person, about 0.41 mA for a large school bus, and about 0.63 mA for a large trailer truck.

When a conducting object is isolated from the ground (e.g. the rubber tires of a vehicle) and a grounded person touches the object, a perceptible current or shock could occur as the current flows to ground. In the case of a person the common terms for this are called: step-and-touch potential. Shocks are classified as below perception, above perception, secondary, and primary. The mean perception level is 1.0 mA for a 180-pound man and 0.7 mA for a 120-pound woman. Secondary shocks cause no direct physiological harm, but could annoy a person and cause involuntary muscle contraction. The lower average secondary shock level for an average sized man is about 2 mA. Primary shocks can be harmful. Their lower level is described as the current at which 99.5 percent of subjects can still voluntarily “let go” of the shocking electrode. For a 180-pound man this is 9 mA, for a 120-pound woman, 6 mA, and for children, 5 mA. The NESC specifies 5 mA as the maximum allowable short-circuit current-to-ground from vehicles, trucks, and equipment near transmission lines.

The mitigation for hazardous and nuisance shocks is to ensure that metallic objects on or near the ROW are grounded, and that sufficient clearances are provided at roadways and parking lots to keep electric fields at these locations sufficiently low to prevent vehicle short circuit currents from exceeding 5 mA.

Magnetic fields can also induce voltages and currents in conducting objects. Typically, this requires a long metallic object, such as a wire fence or aboveground pipeline that is grounded at only one location. A person who closes an electrical loop by grounding the object at a different location will experience a shock similar to that previously described for an ungrounded object. Mitigation for this problem is to ensure multiple grounds on fences or pipelines, especially those that are oriented parallel to the transmission line.

The proposed 138kV gen tie will be constructed in conformance with CPUC GO-95 and Title 8 CCR 2700 requirements. Therefore, hazardous shocks are unlikely to occur as a result of Project construction, operation, or maintenance.

2.3.7.7 Communications (Radio or Television) Interference

The communication interference (radio or television) for the proposed Project 138kV gen tie has been calculated for two different environmental conditions applied to the new gen tie—the heavy rain condition and the fair weather condition.

The North American Regional Broadcasting Agreement recognizes a 54 decibel (dB) signal level as the outer boundary of an AM radio station's primary service territory. The amount of AM radio interference caused by the gen tie depends on the relative signal strength of the radio signal and other sources of ambient radio noise. The Federal Communications Commission (FCC) recommends the following minimum signals as necessary to reliably serve a primary service area:

- Business City Area: 80 to 94 dB
- Residential City Area: 66 to 80 dB
- Rural Area: 40 to 54 dB

The requirements for higher signal strengths in city areas takes into consideration the higher level of ambient noise levels typically found in the city as compared with a rural location.

Good radio reception is typically based on a signal strength 26 dB greater than ambient noise. This 26 dB signal-to-noise ratio is applied to the fair weather ambient noise level. A commonly accepted level of transmission radio noise is 40 to 45 dB at the edge of ROW for fair weather conditions. A 40 dB noise level and 26 dB signal-to-noise ratio would imply a signal strength of 66 dB, which agrees with recommended signal strength as listed above for a residential city area.

Digital communication (digital radio and TV) and FM radio is immune to corona type radio noise and, therefore, is not considered in evaluation of transmission radio interference. Television audio is also an FM signal that is not affected by transmission line radio noise. In the past and in some areas, Television video is an AM signal that is subject to interference from transmission lines. As analog TV is phased out in favor of digital TV, TVI will not be an issue. However, the frequency spectrum for fair weather corona noise follows an inverse law. The transmission noise attenuates at a rate of 20 dB per frequency decade. In addition to attenuation for frequency, an adjustment is made for the different bandwidth of the television signal versus AM radio. When the frequency and bandwidth adjustments are made, the net correction is 10 dB. The expected noise at television frequencies is 10 dB less than for AM radio.

The following is a calculation of potential radio and TV interference levels:

Reference: EPRI's Red Book, Sections 5.3 and 5.4.

Introducing involved parameters:

- RI: Radio interference,
- TVI: Television interference,
- h: Height of closest phase to ground (in m),
- R: Lateral distance from antenna to nearest phase

Assumptions:

- Ground resistivity is taken equal to 100 ohms (Ω).
- Prediction of RI & TVI is made for an antenna located at 100 m from the line.
- Frequency of interest for RI and TVI prediction is assumed to be 83.25 MHz (carrier frequency of TV channel 6 with a grade B signal of 47dB above 1 $\mu\text{V/m}$).
- RI and TVI have been calculated for heavy rain condition as the worst case.
- RI level of 362kV line has been considered as the base case and correction factors and dB adders have been extrapolated. This assumption will result in conservative values as 138kV line has smaller corona than a 362kV line. Base case parameters are:
 - Line voltage: 362kV,
 - Phase arrangement and spacing: Vertical and 7.5 m,
 - Lowest phase to ground clearance: 12.5 m

Calculations:

- RI level in heavy rain from base case graph (introduced reference): 73.2 dB,
- Adjustment due to voltage level from corresponding graph: -18.5 dB,
- Adjustment due to phase spacing: +2.2 dB from corresponding graph,
- Adjustment due to average height above ground from corresponding graph: +0.5 dB,
- 3.2 = Constant
- Tie-Line project's RI = $73.2 - 18.5 + 2.2 + 0.5 = 57.4$ dB above 1 $\mu\text{V/m}$,
- $\text{TVI} = \text{RI} - 20 \text{Log}_{10}(\frac{(1 + (R/h)^2)}{(1 + (15/h)^2)})^{0.5} + 3.2 = 57.4 - 54.18 + 3.2 = 6.42$ dB above 1 $\mu\text{V/m}$,
- $\text{SNR (Signal to Noise ratio)} = 47 - 6.42 = 40.58$ dB.

Referring to SNR rating scale (graph 5.3.5 of introduced reference), TVI of the project is less than scale 3 and is within the acceptable range. SNR in other conditions such as wet conductor or dry weather condition is much smaller and is actually negligible.

2.4 ONSITE 138KV PLANT SWITCHYARD PROJECT DESCRIPTION

The 138kV gen tie will include an onsite 138kV switchyard within the fenceline of the power plant. The proposed onsite 138kV switchyard will consist of a single 138kV gas-insulated (SF6) circuit breaker, associated disconnect switches, interconnecting bus structures, and two dead end structures. The rigid aluminum bus structures, or strain bus, will be connected to the new 138kV gen tie and generator step-up transformer (GSUT) through 60-foot dead-end structures on the north and south end of the switchyard, respectively. The onsite 138kV plant switchyard and all associated equipment will be designed for 1,000 amperes (A) continuous current and a 40 kiloampere interrupting capacity (kAIC).

The GSUT high side bushings shall be connected to the onsite plant switchyard via the 138kV gen tie. A dead end structure shall be provided adjacent to the GSUT. Each cluster of generator sets would be provided with an independent tie to a dedicated low side winding of the GSUT via 15kV non-segregated-phase bus duct.

The onsite plant switchyard will be equipped with two separate 15kV metal-clad switchgear lineups. Each switchgear would collect power from a cluster of five to six generator sets and transmit this power to a dedicated GSUT winding. One 13.8kV-480V auxiliary power transformer will be connected to each 15kV switchgear. The auxiliary power transformers would provide power to all auxiliary loads within the plant. Startup and standby power would be supplied from the grid through the GSUT, which will backfeed 13.8kV power into the power plant 15kV switchgear and to the respective auxiliary transformers. Alternatively, startup and standby power might be provided by separate 480 volt services from the local distribution system, if available.

Auxiliary controls and protective relay systems for the onsite 138kV plant switchyard would be installed in a controlled enclosure on the west side of the onsite plant switchyard.

2.5 GEN TIE CONSTRUCTION

Construction deliveries for the 138kV gen tie will be the same as described for the Project in Section 2.3.13.4 of the AFC with one minor exception. Construction of three gen tie poles adjacent to the SDG&E Carlton Hills Substation and modification of the existing Carlton Hills Substation will require access from east of the Carlton Hills Substation. Approximately eight round trips of heavy trucks will be required for construction of the three gen tie poles. Approximately 16 round trips of heavy trucks will be required for the modification of the Carlton Hills Substation by SDG&E. Pickup trucks will be used to transport construction workers from the Project construction parking area at 7927 Mission Gorge Road in the City of Santee to the Carlton Hills Substation property. The timeframe for the construction of the three gen tie poles adjacent to the Carlton Hills Substation and modifications to the Carlton Hills Substation will be approximately three months.

2.6 TEMPORARY CONSTRUCTION LAYDOWN AREA DESCRIPTION

The proposed temporary construction laydown area will be approximately 5 acres, as presented in the AFC. The proposed laydown area will be located within the 20-acre area depicted on Figure 1.1-1. The location of the laydown area is approximately 0.5 mile north of the location presented in the AFC. This minor change will result in very minimal additional environmental impacts, as access to the laydown area will still be along Sycamore Landfill Road, a private road.

This page intentionally left blank.

3.0 PROPOSED PROJECT AND ALTERNATIVES

This Supplement only proposes to change the gen tie route and voltage and the location of the temporary construction laydown area of the proposed Project. The proposed Project continues to be a nominal 100 MW intermediate/peaking load facility using natural gas-fired reciprocating engine technology. As proposed in the AFC, the Project includes a power generation facility located on a 21.6-acre site and a natural gas pipeline. This Supplement proposes a new 138kV gen tie instead of the 230kV gen tie described in the AFC. This Supplement includes a proposed 138kV gen tie and three 138kV alternative gen ties, described below.

As described in Section 2.0 of this document, the change from the 230kV gen tie to the 138kV gen tie eliminates the need for the SDG&E 230kV utility switchyard and changes the gen tie route alignment and the gen tie voltage to 138kV. Unless otherwise noted in this section, the information presented in Section 3.0 of the AFC and the Supplement to the AFC would not change per the revised gen tie voltage and alignment. The descriptions of AFC alternatives are taken from the Supplement to the AFC. The Project objectives are the same as described in Section 3.1 of the AFC, and the Project with the 138kV gen tie will enhance the reliability and availability of SDG&E's transmission system in the San Diego area.

3.1 COMPARISON OF PROPOSED PROJECT AND ALTERNATIVES

Section 3.3 of the previously filed AFC and Supplement to the AFC contain a comparison of the proposed Project and alternatives. This Supplement analyzes the new proposed 138kV gen tie and three additional 138kV gen tie alternatives to the proposed 138kV gen tie, which are being considered by the Applicant and are described in Section 2.2 of this Supplement (Figure 1.1-1):

- Project with Proposed 138kV gen tie
- Project with Alternative 1 138kV gen tie;
- Project with Alternative 2 138kV gen tie; and
- Project with Alternative 3 138kV gen tie.

The AFC alternatives included an analysis of the 230kV gen tie. Because the original POI at SDG&E Mission-Miguel 230kV transmission line is no longer an option for the Project, these alternatives are no longer feasible as the CAISO will only recognize one POI for the Project. However, for the purposes of this analysis, the 230kV AFC gen tie alternatives will be compared to the Project with the proposed 138kV gen tie.

Each alternative was evaluated on the basis of the AFC environmental areas, and estimated engineering and economic costs associated with the various perceived mitigation measures. Table 3.1-1 summarizes institutional factors, engineering/construction feasibility, length of linear features, and whether a gen tie alternative is feasible or not from an environmental impact perspective as compared to the new proposed 138kV gen tie and the 230kV gen tie proposed in the AFC.

3.1.1 Proposed 138kV Gen Tie

The proposed 138kV gen tie is shown on Figure 1.1-1. The Applicant does not currently have an easement for the proposed 138kV gen tie; however there is reason to believe that the easement

could potentially be acquired. The length of the power plant access road for the Project with the proposed 138kV gen tie is 2,000 feet. The length of the gas lateral is 2,032 feet. The length of the new gen tie access road for the proposed 138kV gen tie is 1,382 feet. Construction of the proposed 138kV gen tie would use existing SDG&E access roads for the remainder of the proposed 138kV gen tie.

The proposed 138kV gen tie will connect the Project to the existing SDG&E 138kV Carlton Hill Substation. To accommodate the proposed 138kV gen tie, SDG&E will expand the existing 138kV air insulated buswork within the existing fence line at the existing SDG&E Carlton Hills Substation.

3.1.2 Alternative 1 138kV Gen Tie

The Alternative 1 138kV gen tie is shown on Figure 1.1-1. The Applicant does not currently have an easement for the Alternative 1 138kV gen tie; however there is reason to believe that the easement could potentially be acquired. Alternative 1 138kV gen tie would result in potentially greater impacts to cultural resources, biological resources, transportation, and visual resources than the Project with the proposed 138kV gen tie.

Regarding length of linear features for the Alternative 1 138kV gen tie, the length of the power plant access road is 2,000 feet and gas lateral is 2,032 feet, which would be the same as the proposed 138kV gen tie. Since the Alternative 1 138kV gen tie does not follow the existing 138kV line for the majority of its length, the length of new gen tie access road to be constructed for this alternative is 4,858 feet, which would be 3,476 feet longer than the proposed 138kV gen tie. As the total length of linear features to be constructed for Alternative 1 138kV gen tie is greater than the proposed 138kV gen tie, the impacts to biological and cultural resources from the Alternative 1 138kV gen tie would potentially be slightly greater than the proposed 138kV gen tie. However, the impacts to biological and cultural resources would still be less than significant.

Transportation impacts during construction would be greater for Alternative 1 138kV gen tie over the proposed 138kV gen tie because slightly more construction traffic would be necessary as a gen tie access road would need to be constructed.

Table 3.1-1 Comparison of the Proposed Project and Alternatives

Characteristic	Project with Proposed 138kV Gen Tie	Project with Alternative 1 138kV Gen Tie	Project with Alternative 2 138kV Gen Tie	Project with Alternative 3 138kV Gen Tie	AFC Alternative A	AFC Alternative B	AFC Alternative C
Institutional Factors							
Site control	No	No	No	No	No	No	No
Ability to obtain required permits	Feasible	Feasible	Feasible	Less feasible	Less feasible	Less feasible	Less feasible
Engineering/Construction Feasibility							
Underground transmission line required	No	No	Yes	No	Yes	Yes	No
New 230kV switchyard and access road construction required	No	No	No	No	Yes	Yes	Yes
New power plant access road construction required	Yes	Yes	Yes	Yes	Yes	Yes	Yes
Equal or more difficult engineering constraints for new power plant access road than proposed project	n/a	n/a	n/a	n/a	Yes	Yes	Yes
Equal or greater site grading requirements than proposed project	n/a	Yes	No	No	Yes	Yes	Yes
Equal or greater engineering costs than proposed project	n/a	Yes	Yes	No	Yes	Yes	Yes
Length of Linear Features							
Length of power plant access road (feet)	2,000	2,000	2,000	2,000	4,800	6,400	8,700
Length of gas lateral (feet)	2,032	2,032	2,032	2,032	4,764	6,416	8,669
Length of new gen tie access road ¹ (feet)	1,382	4,858	1,382	2,150	2,200	800	1,500
Total length of linear features (feet) ²	5,414	8,890	5,414	6,182	11,764	13,616	18,869
Environmental Factors³							
Cultural resources impacts with mitigation	-	Greater than	Equal to	Greater than	Greater than	Greater than	Greater than
Land use impacts with mitigation	-	Equal to	Equal to	Equal to	Equal to	Equal to	Equal to
Noise impacts with mitigation	-	Equal to	Equal to	Equal to	Equal to	Equal to	Equal to
Traffic and transportation impacts with mitigation	-	Greater than	Equal to	Greater than	Greater than	Greater than	Greater than
Visual resources impacts with mitigation	-	Equal to	Equal to	Equal to	Equal to	Greater than	Greater than
Socioeconomics impacts with mitigation	-	Equal to	Equal to	Equal to	Equal to	Equal to	Equal to
Air quality impacts with mitigation	-	Equal to	Equal to	Equal to	Greater than	Equal to	Equal to
Public health impacts with mitigation	-	Equal to	Equal to	Equal to	Equal to	Equal to	Equal to
Hazardous materials handling impacts with mitigation	-	Equal to	Equal to	Equal to	Equal to	Equal to	Equal to
Worker health and safety impacts with mitigation	-	Equal to	Equal to	Equal to	Equal to	Equal to	Equal to
Waste management impacts with mitigation	-	Equal to	Equal to	Equal to	Equal to	Equal to	Equal to

Table 3.1-1 Comparison of the Proposed Project and Alternatives (continued)

Characteristic	Project with Proposed 138kV Gen Tie	Project with Alternative 1 138kV Gen Tie	Project with Alternative 2 138kV Gen Tie	Project with Alternative 3 138kV Gen Tie	AFC Alternative A	AFC Alternative B	AFC Alternative C
Biological resources impacts with mitigation	–	Greater than	Equal to	Greater than	Greater than	Greater than	Greater than
Water resources impacts with mitigation	–	Equal to	Equal to	Equal to	Equal to	Equal to	Equal to
Agriculture and soils impacts with mitigation	–	Equal to	Equal to	Equal to	Equal to	Equal to	Equal to
Paleontological resources impacts with mitigation	–	Equal to	Equal to	Equal to	Equal to	Equal to	Equal to
Geological hazards and resources impacts with mitigation	–	Equal to	Equal to	Equal to	Equal to	Equal to	Equal to

Notes:

1. The gas lateral and the power plant access road are sited along the same route for each of these alternatives.
2. Environmental impacts of alternative sites categorized as greater than, equal to, or less than the proposed Project – plus the proposed 138kV gen tie.

All other environmental impacts of Alternative 1 138kV gen tie would be the same as the proposed 138kV gen tie. Regarding engineering/construction feasibility, the Alternative 1 138kV gen tie would be less feasible as compared to the proposed 138kV gen tie. From an engineering perspective, the Alternative 1 138kV gen tie would be more difficult to construct than the proposed 138kV gen tie because the proposed 138kV gen tie would use the existing SDG&E access roads during construction, and new access roads would be required to construct the Alternative 1 138kV gen tie. The Alternative 1 138kV gen tie would be subject to equal site grading requirements and greater engineering costs than the proposed 138kV gen tie.

3.1.3 Alternative 2 138kV Gen Tie

The Alternative 2 138kV gen tie is shown on Figure 1.1-1. The Applicant does not currently have an easement for the Alternative 2 138kV gen tie; however there is reason to believe that the easement could potentially be acquired. The Alternative 2 138kV gen tie would result in potentially greater impacts to cultural resources and biological resources when compared to the proposed 138kV gen tie because a portion of the line would have to be underground.

Regarding length of linear features for the Alternative 2 138kV gen tie, the length of the power plant access road is 2,000 feet and gas lateral is 2,032 feet, which would be the same as the proposed 138kV gen tie. Like the proposed 138kV gen tie, the Alternative 2 138kV gen tie is 1,382 feet and would use the SDG&E access roads for the existing 138kV transmission line to construct this alternative. Spur roads will be constructed off of the existing access road to reach each pole location. However, part of the Alternative 2 gen tie would need to be undergrounded to cross to the north side of the existing 138kV transmission line into the substation. Therefore the engineering constraints would be greater for the Alternative 2 gen tie than for the proposed 138kV gen tie.

Therefore, the Alternative 2 138kV gen tie would be less feasible from an engineering and construction perspective as compared to the proposed 138kV gen tie because part of this alternative gen tie would be undergrounded. All other impacts of Alternative 2 138kV gen tie would be the same as the proposed 138kV gen tie.

3.1.4 Alternative 3 138kV Gen Tie

The Alternative 3 138kV gen tie is shown on Figure 1.1-1; it follows the existing 138kV line for the majority of its length. The Applicant does not currently have an easement for the Alternative 3 138kV gen tie and there may be great difficulty to obtain an easement for this route. Parcel number 3660805700 is currently owned by San Diego County. The County would need to approve an easement through this parcel.

Regarding length of linear features for the Alternative 3 138kV gen tie, the length of the power plant access road is 2,000 feet and gas lateral is 2,032 feet, which would be the same as the proposed 138kV gen tie. The Alternative 3 138kV gen tie follows the existing 138kV line for the majority of its length, but its gen tie access road is 2,150 feet, which is 768 feet longer than the gen tie access road of the proposed 138 kV gen tie. Alternative 3 138kV gen tie would result in potentially greater impacts to cultural resources, biological resources, and transportation than the proposed 138kV gen tie because the length of new gen tie access road to be constructed is 2,150 feet, which is 768 feet longer than the proposed 138kV gen tie.

As the total length of linear features to be constructed for Alternative 3 138kV gen tie is slightly greater than the proposed 138kV gen tie, the impacts to biological and cultural resources from the Alternative 3 138kV gen tie would potentially be slightly greater than the proposed 138kV gen tie. However, the impacts to biological and cultural resources would still be less than significant.

Transportation impacts during construction would be slightly greater for Alternative 3 138kV gen tie over the proposed 138kV gen tie because slightly more construction traffic would be necessary to construct the additional gen tie access road. All other environmental impacts of Alternative 3 138kV gen tie would be the same as the proposed 138kV gen tie.

Regarding engineering/construction feasibility, the Alternative 3 138kV gen tie would similar to the proposed 138kV gen tie as the plant site, plant access road, and gas lateral are the same as the proposed 138kV gen tie.

3.2 AFC ALTERNATIVES

3.2.1 AFC Project Alternative A

The Applicant does not currently have site control for the AFC Alternative A with the 230kV gen tie, however upon obtaining further feedback from the landowners, there is reason to believe that the parcels could potentially be acquired. AFC Alternative A with the 230kV gen tie would result in potentially greater impacts to air quality, transportation, cultural resources, and biological resources than the proposed Project.

Regarding length of linear features, the length of the power plant access road for AFC Alternative A is 4,800 feet, which would be 2,800 feet longer than the proposed Project. The length of the gas lateral for AFC Alternative A is 4,764 feet, which would be 2,732 feet longer than the proposed Project. The length of the gen tie access road for AFC Alternative A's 230kV gen tie is 2,150 feet, which would be 818 feet longer than the proposed 138kV gen tie. AFC Alternative A would also include the construction of the new 230 kV utility substation on 5 acres of undisturbed land that is not required as part of the proposed Project with the proposed 138kV gen tie. As the total length of linear features for AFC Alternative A is greater than the proposed 138kV gen tie and AFC Alternative A includes the new 230kV utility switchyard, the impacts to biological and cultural resources from the Alternative A 230kV gen tie would be potentially greater than for the Project with the proposed 138kV gen tie. However, the impacts to biological and cultural resources would still be less than significant.

AFC Alternative A with the 230kV gen tie presents greater difficulty than the proposed 138kV gen tie regarding institutional and environmental factors. Air quality impacts from operations would be greater because AFC Alternative A would have increased truck traffic on the longer access roads and because AFC Alternative A's 230kV utility switchyard would be located next to an existing 4.5 MW landfill gas combustion facility (with two large flares) that operates 24 hours a day 7 days a week. The cumulative effects of closely situated 230kV utility switchyard and the landfill gas facility would be greater than the proposed Project that utilizes the existing SDG&E Carlton Hills Substation. AFC Alternative A would have increased air impacts during construction due to the need to construct the 230kV utility switchyard and gen tie access road. As a result of the increased air quality impacts during construction, air permitting would be more difficult for AFC Alternative A than for the Project with the proposed 138kV gen tie, which does not have a switchyard.

The 138kV gen tie is concealed from the highway and the Mission Trails Regional Park in large measure by the topography to the east, whereas the 230kV gen tie would have been visible from both vantage points.

Transportation impacts during construction would be greater for AFC Alternative A with the 230kV gen tie than the Project with the proposed 138kV gen tie because more construction traffic would be necessary to construct the 230kV utility switchyard and the longer access road for the utility switchyard over steep terrain. Additionally, as the turning radius for the access road would be very difficult to engineer; the transport of materials to the Alternative A 230kV gen tie components would be more difficult than the proposed 138kV gen tie.

Regarding engineering/construction feasibility, AFC Alternative A would be less feasible as compared to the proposed Project. AFC Alternative A would require an underground transmission line and the proposed Project with the proposed 138kV gen tie would not. From an engineering perspective, Alternative A presents difficulties as the power plant access road would be longer and would have to traverse steeper terrain. Alternative A would be subject to equal or greater site grading requirements and equal or greater engineering costs than the proposed Project with the proposed 138kV gen tie.

3.2.2 AFC Project Alternative B

AFC Alternative B with the 230 kV gen tie presents greater difficulty than the proposed Project with the proposed 138kV gen tie regarding institutional and environmental factors. The Applicant does not currently have site control for AFC Alternative B; however upon obtaining further feedback from the landowners, there is reason to believe that the parcel could potentially be acquired. AFC Alternative B would result in potentially greater impacts to visual resources, transportation, cultural resources, and biological resources than the proposed Project with the proposed 138kV gen tie.

Regarding length of linear features, the length of the power plant access road for AFC Alternative B is 6,400 feet, which would be 4,400 feet longer than the proposed Project. The length of the gas lateral for AFC Alternative B is 6,416 feet, which would be 4,384 feet longer than the proposed Project. The length of the gen tie access road for AFC Alternative B is 800 feet, which would be 582 feet shorter than the proposed Project. As the total length of linear features for AFC Alternative B is greater than the proposed Project and AFC Alternative B includes the construction of the 230kV utility switchyard, the impacts to biological and cultural resources from AFC Alternative B would be potentially greater than for the proposed Project. However, the impacts to biological and cultural resources would still be less than significant.

The 138kV gen tie is concealed from the highway and the park in large measure by the topography to the east, whereas the 230kV gen tie would have been visible from both vantage points.

Due to the greater amount of land disturbance within the Mission Trails Park expansion plan boundary resulting from the longer power plant access road and gas lateral and the increased visual impacts when compared to the proposed Project, the Applicant would expect more push back from the City of San Diego with regard to Alternative B, and therefore, the ability to obtain required permits for this alternative would be less feasible than the proposed Project.

Transportation impacts during construction would be greater for Alternative B over the proposed Project because more construction traffic would be necessary to construct the longer access road over steeper terrain. The access road to the site would present engineering and logistical challenges. The access road grade cannot be greater than 6 percent per SDG&E requirements. Due to the extremely steep slope on this parcel; engineering an access road to these specifications would be difficult in this terrain. Additionally, although construction of the access road may be feasible, the Applicant may not be able to obtain an easement for the access road. The costs of constructing the access road for Alternative B (including obtaining the easement and engineering the access road) would likely be greater than the costs of constructing the access road for the proposed Project.

Regarding engineering/construction feasibility, AFC Alternative B would be less feasible as compared to the proposed Project. AFC Alternative B would require an underground transmission line and the proposed Project with the proposed 138kV gen tie would not. From an engineering perspective, AFC Alternative B presents difficulties as the power plant access road would be longer and would have to traverse steeper terrain. AFC Alternative B would be subject to equal or greater site grading requirements and equal or greater engineering costs than the proposed Project with the proposed 138kV gen tie.

3.2.3 AFC Project Alternative C

AFC Alternative C with the 230kV gen tie presents greater difficulty than the proposed Project with the proposed 138kV gen tie regarding institutional and environmental factors. The Applicant does not currently have site control for AFC Alternative C; however upon obtaining further feedback from the landowners, there is reason to believe that the parcel could potentially be acquired. AFC Alternative C would result in potentially greater impacts to visual resources, transportation, cultural resources, and biological resources than the proposed Project.

Regarding length of linear features, the length of the power plant access road for AFC Alternative C is 8,700 feet, which would be 6,700 feet longer than the proposed Project. The length of the gas lateral for Alternative C is 8,669 feet, which would be 6,637 feet longer than the proposed Project. The length of the gen tie line for AFC Alternative C is 1,500 feet, which would be 118 feet longer than the proposed Project with the proposed 138kV gen tie. As the total length of linear features for AFC Alternative C is greater than the proposed Project and AFC Alternative C includes construction of the 230kV utility switchyard, the impacts to biological and cultural resources from AFC Alternative C would be potentially greater than the proposed Project with the proposed 138kV gen tie. However, the impacts to biological and cultural resources would still be less than significant.

The 138kV gen tie is concealed from the highway and the park in large measure by the topography to the east, whereas the 230kV gen tie would have been visible from both vantage points.

Due to the greater amount of land disturbance within the Mission Trails Park expansion plan boundary resulting from the longer power plant access road and gas lateral and the increased visual impacts when compared to the proposed Project, the Applicant would expect more push back from the City of San Diego with regard to Alternative C, and therefore, the ability to obtain required permits for this alternative would be less feasible than the proposed Project.

Transportation impacts during construction would be greater for Alternative C over the proposed Project because more construction traffic would be necessary to construct the longer access road over steeper terrain. The access road to the site would present engineering and logistical challenges. The access road grade cannot be greater than 6 percent per SDG&E requirements. Due to the extremely steep slope on this parcel, engineering an access road to these specifications would be difficult in this terrain. Additionally, although construction of the access road may be feasible, the Applicant may not be able to obtain an easement for the access road, though it is feasible. The costs of constructing the access road for Alternative C (including obtaining the easement and engineering the access road) would likely be greater than the costs of constructing the access road for the proposed Project.

Regarding engineering/construction feasibility, AFC Alternative C would be less feasible as compared to the proposed Project with the proposed 138kV gen tie. AFC Alternative C would not require an underground transmission line and neither would the proposed 138kV gen tie. AFC Alternative C would require a new power plant access road as would the proposed Project. AFC Alternative C presents difficulties as the power plant access road would be longer and would have to traverse a steeper terrain. AFC Alternative C would be subject to equal or greater site grading requirements and equal or greater engineering costs than the proposed Project with the proposed 138kV gen tie.

3.3 COMPARISON OF THE PROJECT WITH THE PROPOSED 138KV GEN TIE TO THE PROJECT ORIGINALLY PROPOSED WITH THE 230KV GEN TIE

Table 3.2-2 contains a comparison of the ground disturbing impacts resulting from the originally proposed Project with the 230kV gen tie as presented in the AFC versus the proposed 138kV gen tie. As the power plant site, gas lateral, and construction laydown area have not changed, the impacts from these Project components are equal. The SDG&E 230kV utility switchyard would have disturbed approximately 5 acres and the construction of the utility switchyard and gen tie access roads for the 230kV gen tie would have disturbed approximately 16 acres. The 138kV gen tie would not require the utility switchyard and would have a shorter gen tie access road than the Project as proposed in the AFC, therefore the 138kV Project would result in 17 fewer acres of ground disturbance as compared to the originally proposed Project.

Table 3.2-2 Comparison of 230kV Project Impacts and 138kV Project Impacts

Project Component	230kV Project Impacts	138kV Project Impacts
Power plant site	11 acres	11 acres
SDG&E utility switchyard	5 acres (new 230kV switchyard construction)	0 acres (existing 138kV Carlton Hills Substation)
Natural gas pipeline lateral	2,200 linear feet (1,500 cubic yards of disturbed soil)	2,200 linear feet (1,500 cubic yards of disturbed soil)
Length of gen tie line	5,600 feet	6,850 feet
New gen tie access road ¹	5,600 linear feet (16 acres)	1,382 linear feet (4 acres)
Construction laydown area	5 acres	5 acres

¹ Disturbance associated with the gen tie access road assumes a ROW width of 125 feet. This calculation includes the total length of new access road to be constructed. Spur roads to each transmission tower are not included in this estimate. The total number of spur roads to be constructed for the 230kV Project and the 138kV Project would be approximately equal as the overall length of each gen tie would be approximately the same therefore the total number of transmission towers would be the same.

3.4 COMPARISON OF ENGINEERING, ECONOMIC, AND ENVIRONMENTAL MERITS OF FEASIBLE ALTERNATIVES TO THE PROJECT

The alternative gen tie routes and AFC Project Alternatives A, B and C were determined to feasibly attain most of the basic objectives of the project. Regarding environmental factors, air quality impacts would be greater and permitting would be more difficult for AFC Alternative A than the proposed Project with the proposed 138kV gen tie. Transportation impacts would be greater for all alternatives except Alternative 2 138kV gen tie than the proposed Project with the proposed 138kV gen tie. The permitting requirements for AFC Alternatives A, B, and C would be less feasible than the proposed Project with the proposed 138kV gen tie. Alternative 2 138kV gen tie, AFC Alternative A, and AFC Alternative B would have potentially greater impacts to biological and cultural resources due to undergrounding of the gen tie line.

Regarding engineering/construction feasibility, the engineering/construction requirements for all alternatives are greater than or equal to the proposed Project for new gen tie access road construction, new power plant access road construction, engineering constraints for new power plant access road, site grading requirements, and engineering costs. As the SDG&E 230kV utility switchyard would not be constructed for the proposed Project with the proposed 138kV gen tie, engineering constraints for this feature would be greater for AFC Alternatives A, B, and C. Alternative 2 138kV gen tie, AFC Alternative A, and AFC Alternative B require construction of an underground transmission line, but the proposed Project with the proposed 138kV gen tie, Alternative 1 138kV gen tie Alternative 3 138kV gen tie, and AFC Alternative C do not.

Regarding lengths of linear features, the proposed Project with the proposed 138kV gen tie and Alternative 2 138kV gen tie would require construction of a shorter gen tie access road than all other alternatives. In this respect, all alternatives except Alternative 2 138kV gen tie would increase impacts over the proposed Project with the proposed 138kV gen tie because environmental impacts associated with the construction of a longer gen tie (e.g., increased surface disturbance and potential disturbance of sensitive biological and cultural resources) would be increased if any of the other alternatives were constructed. However, since an underground transmission line would be constructed for Alternative 2 138kV gen tie, the potential disturbance of sensitive biological and cultural resources would be increased if the Alternative 2 138kV gen tie was constructed. The overall impacts to biological and cultural resources from all alternatives would be potentially greater than the proposed Project; however the impacts to biological and cultural resources would still be less than significant.

4.0 ENVIRONMENTAL INFORMATION

The subsections in Section 4.0 of the Project AFC provide the information for the 16 environmental, public health and safety, and local impact assessment disciplines required by the California Energy Commission (CEC), Energy Facilities Siting Regulations (Title 20, California Code of Regulations, Section 1704, Appendix B).

Unless otherwise identified in this Supplement to the AFC, it is assumed that for each of the 16 disciplines, there is no change to the Affected Environment, Significance Criteria, Mitigation Measures, and LORS sections of the AFC as a result of the change to the 138kV gen tie and revised location of the temporary construction laydown area. The focus of this section is to provide an analysis of the potential environmental consequences of the construction and operation of the Project with the 138kV gen tie and revised laydown area. As the 138kV gen tie does not require the SDG&E 230kV utility switchyard to be constructed, the construction and operational impacts associated with the utility switchyard as described in the AFC would not occur.

4.1 CULTURAL RESOURCES

Portions of the proposed 138kV gen tie and alternatives were surveyed during the supplemental field work undertaken by Tetra Tech and two Native American monitors from January 2, 2012 through January 13, 2012. Portions of the 138kV corridors have not been surveyed yet because landowners have not approved access to their land for this purpose. The survey for the proposed 138kV gen tie, Alternative 2 138kV gen tie and Alternative 3 138kV gen tie included a 300-foot wide corridor because the proposed ROW abuts the existing ROW and the intent is to mirror the existing pole locations. The survey for the Alternative 1 138kV gen tie included a 400-foot wide corridor because a portion of this alternative crosses an undeveloped area and the wider buffer provides more flexibility in siting pole locations.

Based on the preliminary findings of the supplemental surveys carried out along the gen tie that resulted in 4 new isolated finds and 2 new sites being recorded, the potential impacts to cultural resources as a result of the 138kV gen tie and laydown area are not anticipated to be significantly different than those previously described in Section 4.1 of the AFC. Overall, it is anticipated that potential impacts to cultural resources will be lessened due to the overall decrease in disturbance area. To the extent practicable, the gen tie will avoid sites found during the supplemental surveys.

An addendum to the original cultural resources technical report that was filed under confidential cover with the AFC is being prepared and will be provided to the CEC under confidential cover by mid-February 2012.

4.2 LAND USE

Potential impacts to land use as a result of the Proposed 138kV gen tie and laydown area would be the same as those described in Section 4.2 of the AFC as the Project has not substantively changed from the Project as described in the AFC, and will still require the same community plan amendment and zone change from the City of San Diego.

4.3 NOISE

Potential noise impacts as a result of the construction and operation of the proposed Project with the 138kV gen tie and laydown area would be the same as those described in Section 4.3 of the AFC because the Project has not substantively changed from the Project as described in the AFC.

An audible noise study was conducted for the 138kV preferred gen tie and the results are presented in Section 2.3.7.5 of this Supplement. The maximum audible noise level is 24 A-weighted decibels (dBA). This level is below all noise standards described in Section 4.3.3.1 of the AFC including the City of San Diego and the City of Santee operational noise standard of a one hour average noise limit in residentially zoned areas of 40 dBA from 10:00 p.m. to 7:00 a.m.

4.4 TRAFFIC AND TRANSPORTATION

The overall level of construction traffic for the Project with the 138kV gen tie would not change from that described in the AFC as a result of the revised gen tie alignment. However, access would be required from east of the Carlton Hills Substation to construct three of the gen tie poles adjacent to the substation and make modifications to the substation. Construction traffic will consist of 24 round trips of heavy trucks and transportation of construction workers via pickup trucks as described in Section 2.1 of this document. Construction traffic will access the SDG&E Carlton Hills Substation property by heading east on Mast Boulevard and north on Medina Drive to the substation entrance. Construction traffic will drive through a residential subdivision for less than ¼ mile. The timeframe for the construction of the three gen tie poles adjacent to the substation and modifications to the substation will be approximately three months. Considering the short term nature of this construction period and the strict adherence to an approved Traffic Management Plan (described in Section 4.4 of the AFC), it is expected that construction of the 138kV gen tie will have a less than significant impact on traffic and transportation. Overall, it is anticipated that potential impacts to construction traffic will be lessened due to the overall decrease in disturbance area.

4.5 VISUAL RESOURCES

The visual resources assessment in Section 4.5 of the AFC would not change for the Project with the 138kV gen tie. Overall, the visual impacts of the Project will be decreased, as the SDG&E 230kV utility switchyard and the 1 mile long access road from the plant site to the utility switchyard will not be constructed. The Proposed 138kV gen tie will be constructed adjacent to an existing transmission line and no new access road will be constructed for the proposed gen tie. Siting of the proposed 138kV gen tie adjacent to an existing transmission line would minimize visual impacts when compared to the construction of a gen tie for the 230kV gen tie in a previously undisturbed area. In addition, the 138kV gen tie is concealed from the highway and the park in large measure by the topography to the east, whereas the 230kV gen tie would have been visible from both vantage points.

After the Supplement to the AFC was docketed with the CEC, a line of sight analysis was prepared for 4 observation points east of the Project site. Figures 4.5-1 through 4.5-4 show the line of sight profile of the land that would be visible from each observation point when looking

toward the plant site. The Project plant site would not be visible from any of the 4 observation points.

4.6 SOCIOECONOMICS

Potential socioeconomic impacts as a result of the 138kV Transmission System and laydown area would be the same as those described in Section 4.6 of the AFC because the change in gen tie alignment does not result in any socioeconomics changes for the Project.

4.7 AIR QUALITY

Potential air quality impacts as a result of the 138kV Transmission System and laydown area would be less than those described in Section 4.7 of the AFC. As the SDG&E 230kV utility switchyard and the one mile access road would not be constructed, air quality impacts due to grading and construction of this site would not occur.

4.8 PUBLIC HEALTH

Potential public health impacts as a result of the 138kV Transmission System and laydown area would be the same as those described in Section 4.8 of the AFC as the Project has not substantively changed from the Project as described in the AFC.

4.9 HAZARDOUS MATERIALS HANDLING

Potential hazardous materials handling impacts as a result of the 138kV Transmission System and laydown area would be the same as those described in Section 4.9 of the AFC as the Project has not substantively changed from the Project as described in the AFC.

4.10 WORKER HEALTH AND SAFETY

Potential impacts to worker health and safety as a result of the 138kV Transmission System and laydown area would be the same as those described in Section 4.10 of the AFC as the Project has not substantively changed from the Project as described in the AFC.

4.11 WASTE MANAGEMENT

Potential impacts to waste management as a result of the 138kV Transmission System and laydown area would be the same as those described in Section 4.11 of the AFC as the Project has not substantively changed from the Project as described in the AFC..

4.12 BIOLOGICAL RESOURCES

A biological resources survey of the entire proposed Project including the 138kV gen tie and alternatives is planned for spring 2012. A biological resources report will be docketed at the CEC under separate cover as soon as it is available.

Because habitat along the proposed 138kV gen tie is very similar to that of the previously surveyed 230kV gen tie, the impacts for the proposed 138kV gen tie are expected to be similar to that described in the AFC in terms of pole locations. It is likely that impacts will be reduced because the 230kV switchyard and paved access road will not be built and the 238kV gen tie will be on poles with a smaller footprint than the lattice steel structures required for the 230kV

gen tie. The results of the 2012 spring surveys will provide specific information relative to impacts of the Project.

4.13 WATER RESOURCES

Potential impacts to water resources as a result of the 138kV gen tie and revised laydown area would be the same as those described in Section 4.13 of the AFC as the Project has not substantively changed from the Project as described in the AFC.

4.14 AGRICULTURE AND SOILS

Potential impacts to agriculture and soils as a result of the 138kV Transmission System and laydown area would be the same as those described in Section 4.14 of the AFC as the Project has not substantively changed from the Project as described in the AFC.

4.15 PALEONTOLOGICAL RESOURCES

Potential impacts to paleontological resources as a result of the 138kV Transmission System and laydown area would be the same as those described in Section 4.15 of the AFC as the Project has not substantively changed from the Project as described in the AFC. Overall, it is anticipated that potential impacts to paleontological resources will be lessened due to the overall decrease in disturbance area.

4.16 GEOLOGICAL HAZARDS AND RESOURCES

Potential impacts to geological resources as a result of the 138kV Transmission System and laydown area would be the same as those described in Section 4.16 of the AFC as the Project has not substantively changed from the Project as described in the AFC.

4.17 CUMULATIVE IMPACTS

Cumulative impacts would be the same as those described in Section 4.17 of the AFC as the Project has not substantively changed from the Project as described in the AFC.

5.0 CONCLUSION

The information presented in this Supplement provides a description of a proposed change in the Quail Brush Generation Project gen tie from the Mission-Miguel 230kV transmission line to the SDG&E 138kV Carlton Hills Substation, as well as a move of the temporary construction laydown area to a previously disturbed 5-acre parcel.

This Supplement presents a preliminary impacts analysis of the 138kV gen tie and alternatives. Additional biological and cultural resources surveys will be undertaken this spring on the new gen tie, with permission from landowners, to more definitively determine the potential impacts. Overall, this change in the proposed Project will result in fewer environmental impacts to air quality, biological resources, cultural resources, paleontological resources, and transportation, than the Project with the 230kV Transmission System proposed in the AFC. The change will also result in lower interconnection and upgrade costs, and a shorter construction completion time than the original POI. The CAISO has determined that this change is not a material modification and is currently preparing an additional addendum to the Phase II Interconnection Study and the Phase II Interconnection Addendum.

This page intentionally left blank.

FIGURES

This page intentionally left blank.



Legend

- Project Boundary
- Plant Site
- Offsite Parking
- Preferred Gentie Route with 300 ft Cultural Survey Buffer
- Alternative 1 Gentie Route with 400 ft Cultural Survey Buffer
- Alternative 2 Gentie Route with 300 ft Cultural Survey Buffer
- Alternative 3 Gentie Route with 300 ft Cultural Survey Buffer
- Proposed Gas Lateral
- Existing SDG&E Gas Line
- Existing 138 kV T-Line
- Existing SDG&E 230 kV T-Lines (2)
- Proposed Construction Laydown Area (5 acres within this 20 acre area)
- City Boundary
- Assessors Parcel Number

As the Project is not within a sectioned part of the county, section, township, and range information cannot be provided.



QUAIL BRUSH GENERATION PROJECT

FIGURE 1.1-1
PROJECT LAYOUT

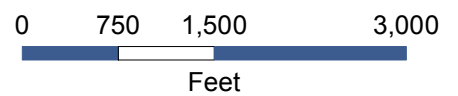

TETRA TECH EC, INC.



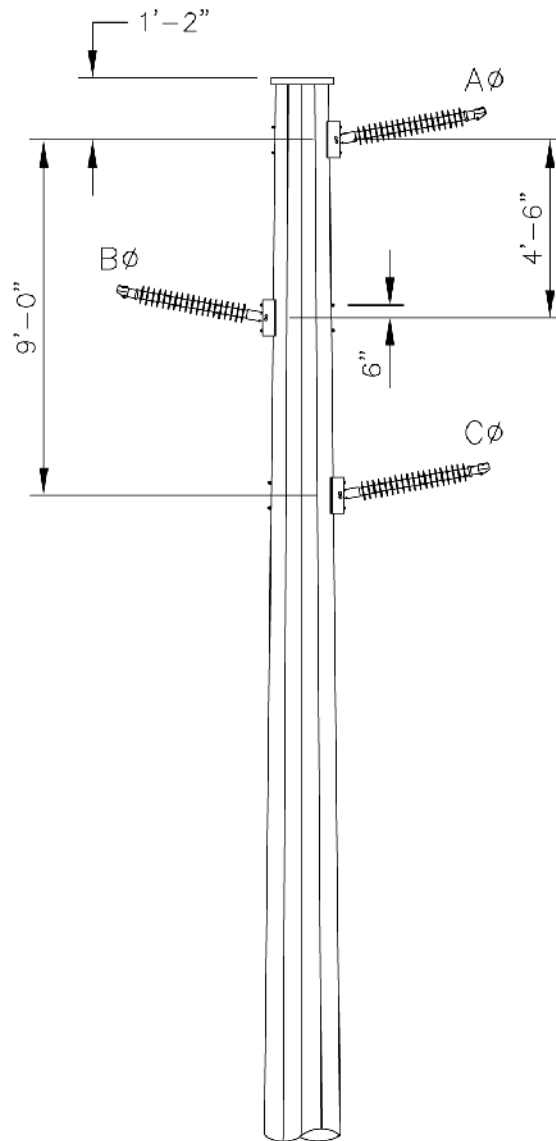

138kV "WPI" TYPE



QUAIL BRUSH GENERATION PROJECT

FIGURE 2.3-1
GEN-TIE
138 kV TRANSMISSION LINE
"WPI"
POLE TOP ARRANGEMENT



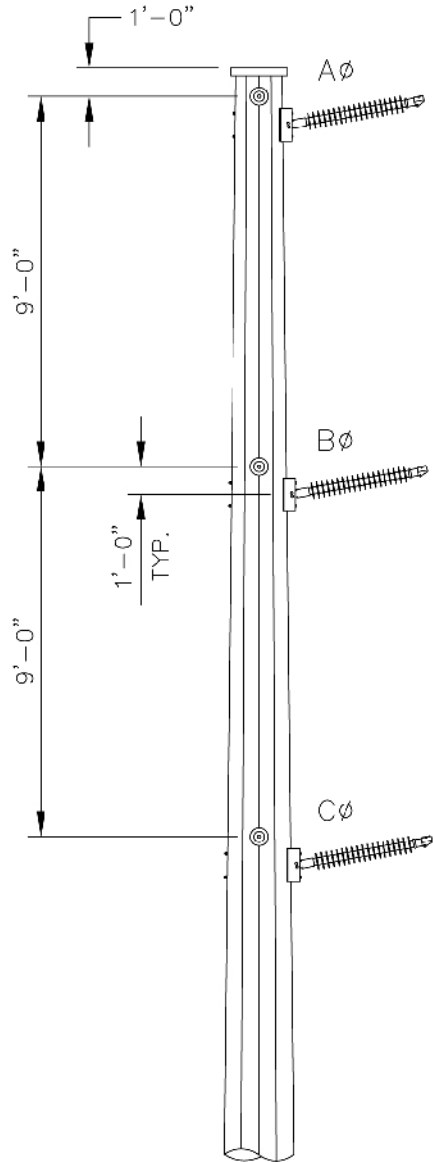

138kV "YPI" TYPE



QUAIL BRUSH GENERATION PROJECT

FIGURE 2.3-2
GEN-TIE
138 kV TRANSMISSION LINE
"YPI"
POLE TOP ARRANGEMENT



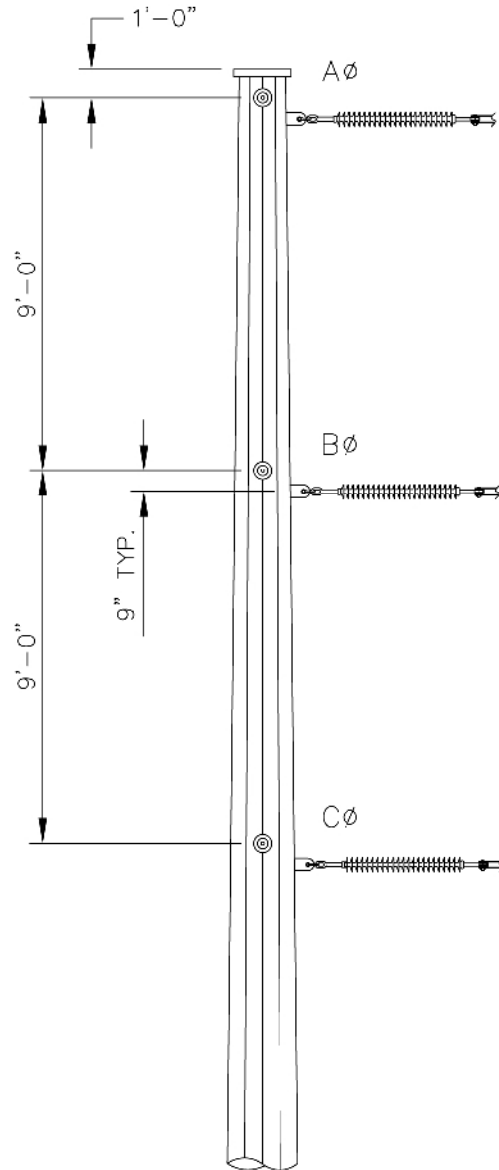

138kV "Y" TYPE



QUAIL BRUSH GENERATION PROJECT

FIGURE 2.3-3
GEN-TIE
138 kV TRANSMISSION LINE
"Y"
POLE TOP ARRANGEMENT



TETRA TECH EC, INC.



P:\GIS_PROJECTS\Cogentrix\QuailBrushEnergyProject\MXD\LineOfSight\Jan2012_Revisions\Cogentrix_QuailBrushEP_LOS_Observer1_11171_012812 - Last Accessed: 1/28/2012 - Map Scale correct at: ANS1 B (17" x 11")

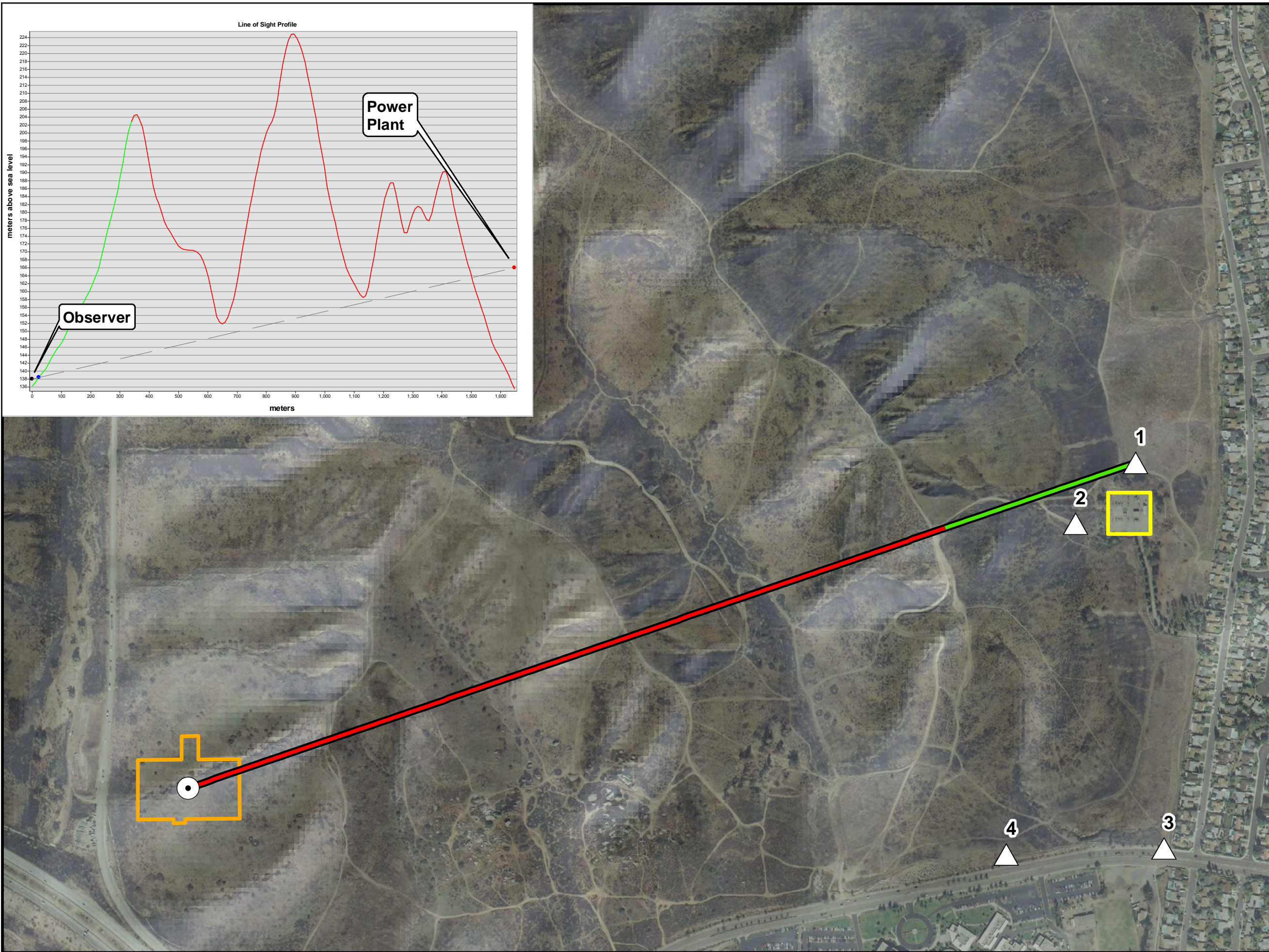
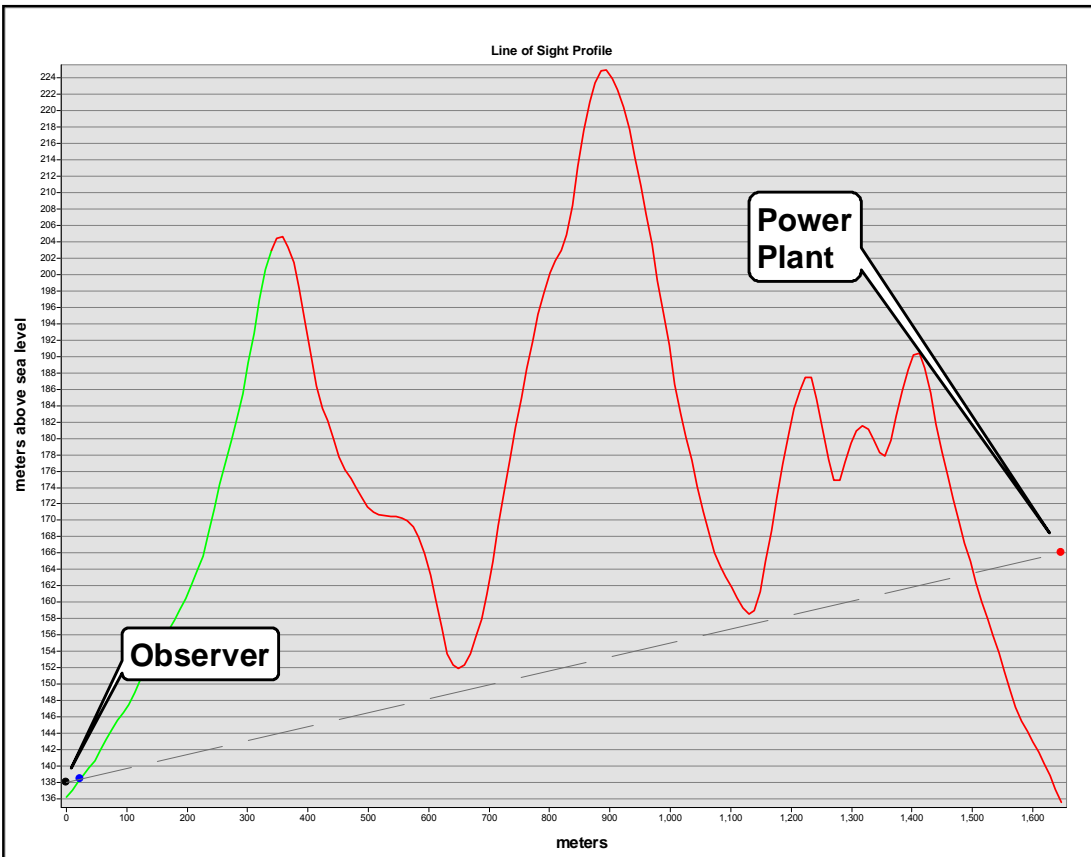

COGENTRIX
Quail Brush Energy Project
 Line-of-Sight Analysis
 Observer Point
 1
 San Diego County, CA
 January 28, 2012

- Observer Point
- Power Plant
- Visible From Observer
- Not Visible from Observer
- Substation
- Power Plant

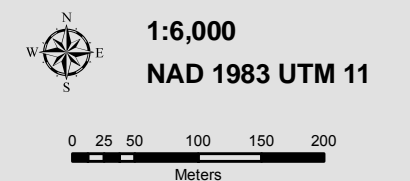

P:\GIS_PROJECTS\Cogentrix\QuailBrushEnergyProject\MXD\LineOfSight\Jan2012_Revisions\Cogentrix_QuailBrushEP_LOS_Observer2_11171_012812 - Last Accessed: 1/28/2012 - Map Scale correct at: ANSIB (17" x 11")

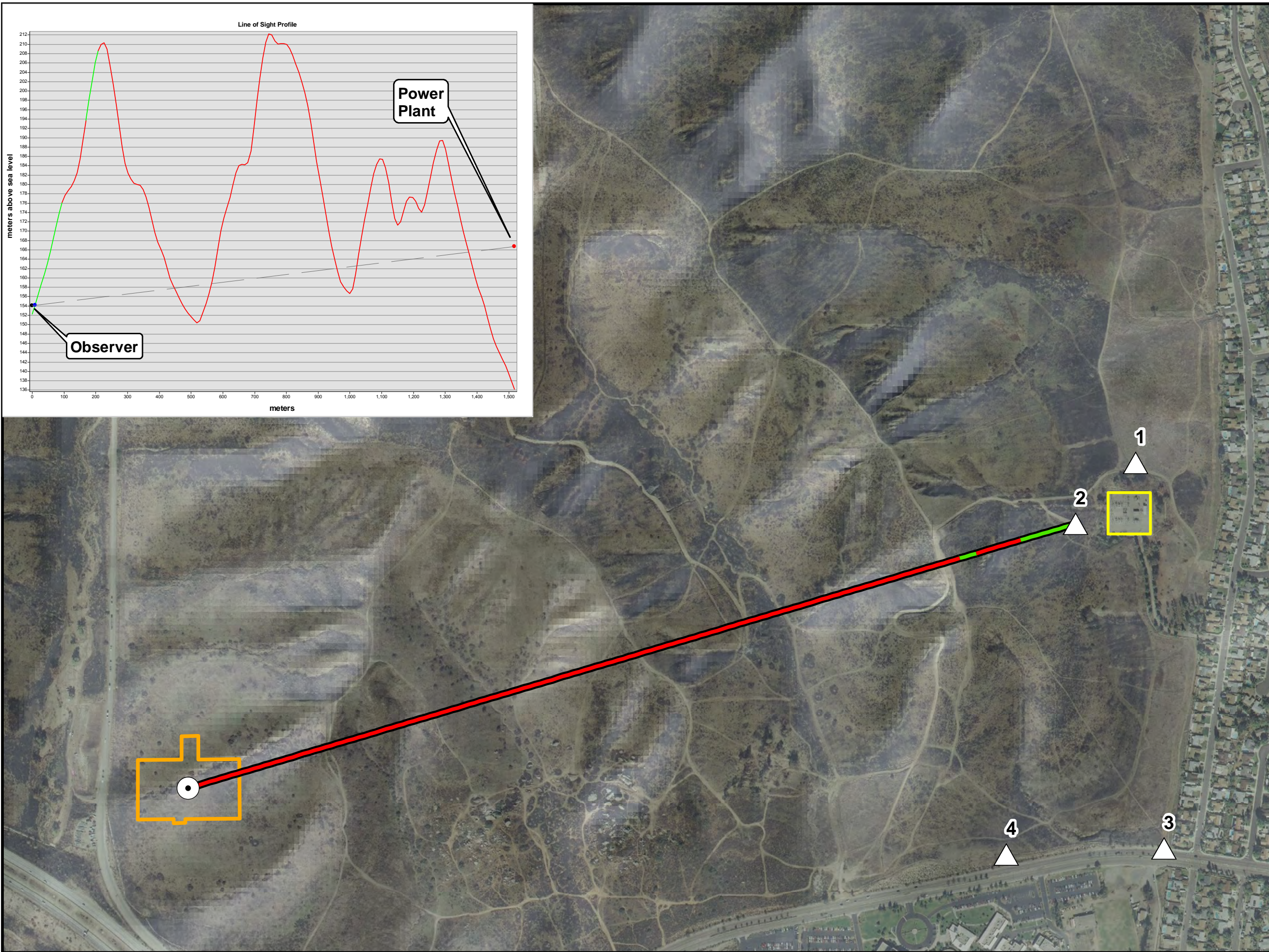
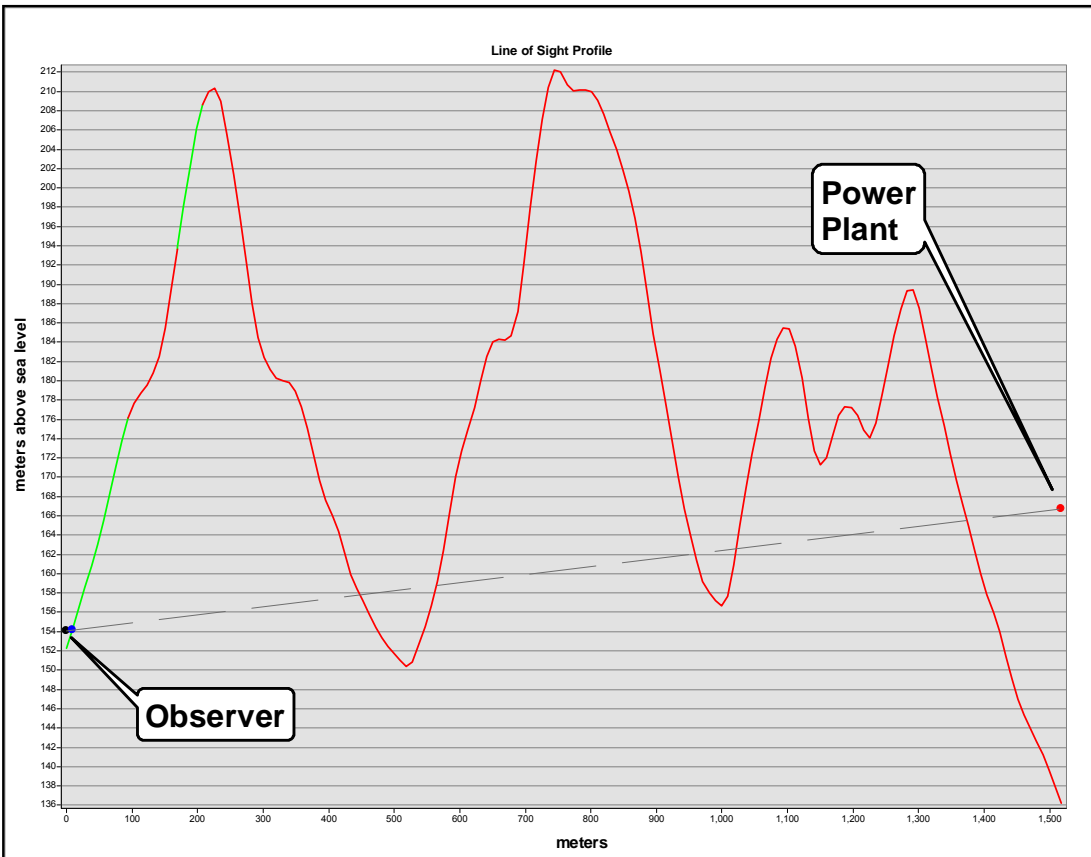

COGENTRIX
Quail Brush Energy Project
 Line-of-Sight Analysis
 Observer Point
 2
 San Diego County, CA
 January 28, 2012

- Observer Point
- Power Plant
- Visible From Observer
- Not Visible from Observer
- Substation
- Power Plant

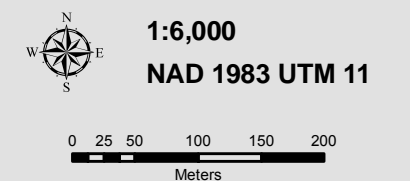

P:\GIS_PROJECTS\Cogentrix\QuailBrushEnergyProject\MXD\LineOfSight\Jan2012_Revisions\Cogentrix_QuailBrushEP_LOS_Observer3_11171_012812 - Last Accessed: 1/28/2012 - Map Scale correct at: ANSIB (17" x 11")

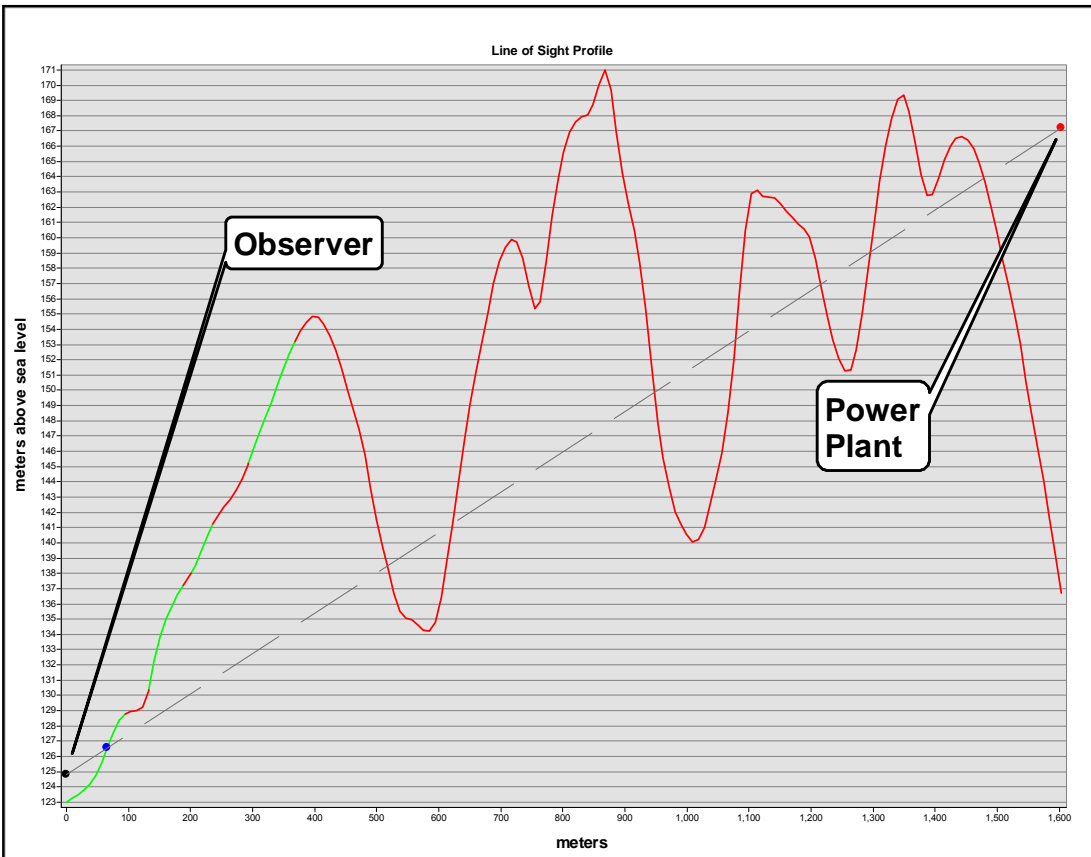

COGENTRIX
Quail Brush Energy Project
Line-of-Sight Analysis
Observer Point
3
 San Diego County, CA
 January 28, 2012

- Observer Point
- Power Plant
- Visible From Observer
- Not Visible from Observer
- Substation
- Power Plant

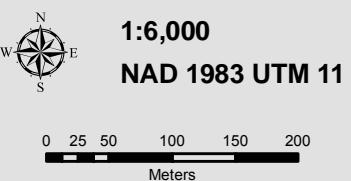

P:\GIS_PROJECTS\Cogentrix\QuailBrushEnergyProject\MXD\LineOfSight\Jan2012_Revisions\Cogentrix_QuailBrushEP_LOS_Observer4_11171_012812 - Last Accessed: 1/28/2012 - Map Scale correct at: ANSIB (17" x 11")

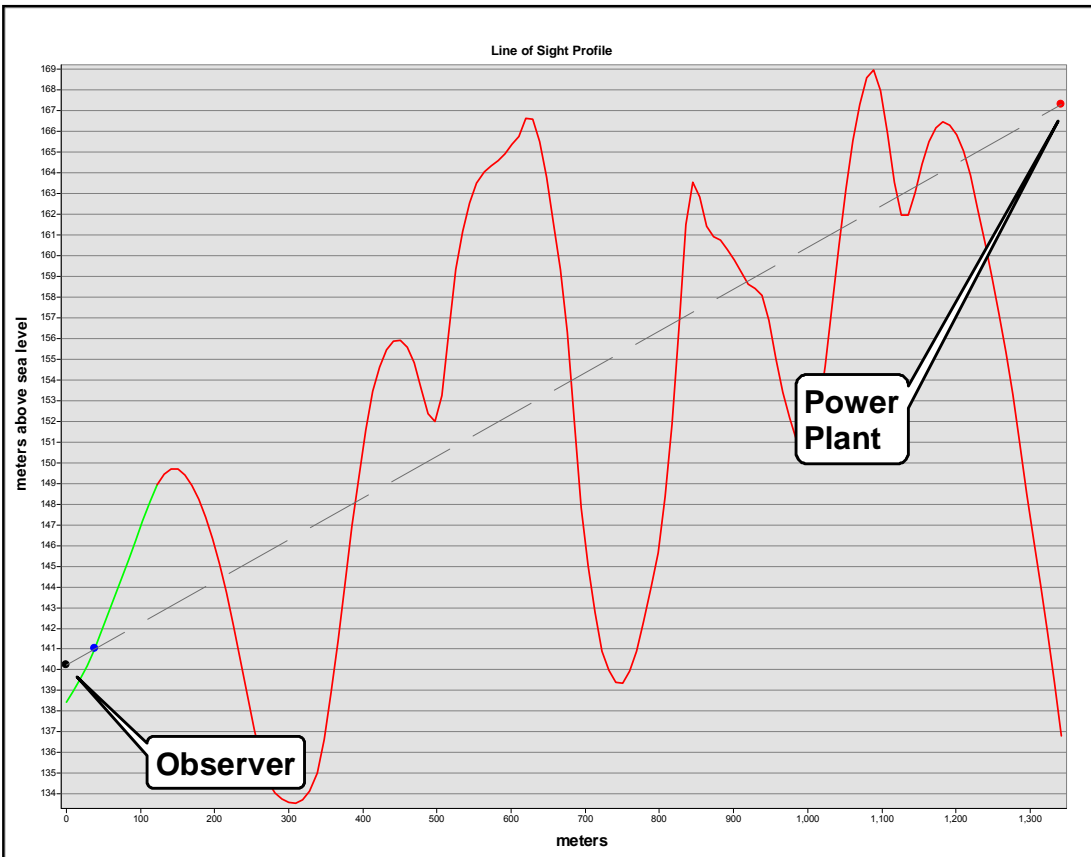

COGENTRIX
Quail Brush Energy Project
Line-of-Sight Analysis
Observer Point
4
 San Diego County, CA
 January 28, 2012

- Observer Point
- Power Plant
- Visible From Observer
- Not Visible from Observer
- Substation
- Power Plant

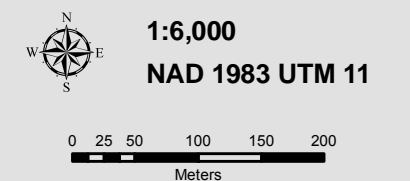

ATTACHMENT A
OCTOBER 18, 2011 LETTER FROM CAISO

This page intentionally left blank.



November 22, 2011

Sent via email

Mr. Richard W. Gray, Jr.
Senior Vice President
Engineering and Construction
Cogentrix Energy, LLC
9405 Arrowpoint Boulevard
Charlotte, NC 28273-8110

RE: Quail Brush Project (Q#565)
Point of Interconnection Modification Determination

Dear Mr. Gray,

Cogentrix Energy, LLC submitted a request to the ISO on October 18, 2011 requesting a change to the Point of Interconnection for the Quail Brush project from the Miguel-Mission 230kV line to the existing Carlton Hills Substation 138kV. The requested change was based on the belief that the new POI would offer significant environmental benefits and substantially lower interconnection and network upgrade costs and a shorter completion time compared to the original POI.

The California ISO has determined that the submitted change is not a material modification. The attached spreadsheet shows the overall expected time and cost savings as a result of this change. Once confirmation is received that Cogentrix will be pursuing this change, an addendum to the Quail Brush project Phase II report will be issued updating the POI, costs and time to construct.

This determination of non-materiality only applies if Cogentrix provides written notification to the California ISO no later than December 9, 2011 which (1) states affirmatively that Cogentrix intends to proceed with the requested modification; and (2) provides all information reasonably requested by California ISO and/or the Participating TO.

Mr. Richard W. Gray, Jr.
November 23, 2011
Page TWO

Please let me know if you wish to discuss this determination further, I can be reached by telephone at 916/351-4470 or by email at lwright@caiso.com.

Sincerely,

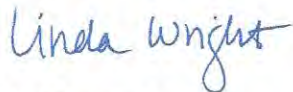

Linda Wright
Project Specialist

Attachment

cc: Dipak Bhagat
Bob Emmert
Luba Kravchuk
Mariam Mirzadeh
Khoang Ngo
Gary Palo
Chris Sibley
Jade Thiemsuwan
Rodney Winter

ATTACHMENT B

**JANUARY 17, 2012 ADDENDUM TO THE CLUSTER PHASE II
INTERCONNECTION STUDY REPORT**

This page intentionally left blank.

Addendum to Appendix A – C565

Cogentrix Energy, LLC

Quail Brush Power Project

Addendum To The Cluster 1 & 2 Phase II Final Report



California ISO
Shaping a Renewed Future

January 17, 2011

This study has been completed in coordination with San Diego Gas & Electric Company per CAISO Tariff Appendix Y Generator Interconnection Procedures (GIP) for Interconnection Requests in a Queue Cluster Window

1. Executive Summary

Cogentrix Energy, LLC, an Interconnection Customer (IC), received a Cluster 1 and 2 Phase II (C1C2 Phase II) study report dated August 24, 2011 for their Interconnection Request (IR) to the California Independent System Operator Corporation (CAISO) for their proposed Quail Brush Power Project (Project), queue position C565.

Subsequent to the Results Meeting with the IC on September 14, 2011, the report is revised to reflect a change in the IC's proposed Point of Interconnection (POI). The change in POI was proposed by San Diego Gas & Electric (SDG&E) and it was agreed by the CAISO, SDG&E and the IC that the change would result in a reduction of costs and timing to interconnect the Project. The original POI proposed by the IC was SDG&E's Miguel-Mission 230 kV transmission line. The revised POI proposed in this addendum is the 138 kV bus of SDG&E's Carlton Hills Substation.

As directed by the CAISO, SDG&E revised the scope and cost of the Interconnection Facilities and Network Upgrades required to physically interconnect the Project at the original POI as studied in the C1C2 Phase II study and has issued this Addendum to the C565 Phase II report to document this change.

The following identified sections and corresponding changes replace and supersede those same sections in the Cogentrix Energy, LLC, Cluster 1 and 2 Phase II (C1C2 Phase II) study report dated August 24, 2011.

Summary of changes:

- A. Replace Section C.1. of the Executive Summary on page 3 to reflect the changes in cost for the PTO's Interconnection Facilities and Network Upgrades to physically interconnect the Project:
 - C. *Specification of required facilities, a non-binding, good faith estimate of the Project's cost responsibility and approximate time to construct the required facilities:*
 1. *The good faith cost estimate of the PTO's Interconnection Facilities¹ to interconnect the Project is approximately [REDACTED], exclusive of ITCC². The good faith cost estimate for the Network Upgrades³ to interconnect the Project and be fully deliverable is approximately [REDACTED] on the SDG&E transmission system and [REDACTED] on the SCE transmission system.*
- B. Add Section 5.1.2 to reflect the results of the steady-state analysis with the revised 138 kV interconnection:

¹ The transmission facilities owned, controlled, or operated by the PTO from the Point of Change of Ownership to the Point of Interconnection necessary to physically and electrically interconnect the Project to the CAISO Controlled Grid.

² Income Tax Component of Contribution

³ The transmission facilities, other than Interconnection Facilities, beyond the Point of Interconnection necessary to accommodate the interconnection of the Project to the CAISO Controlled Grid.

1. The revised steady-state analysis with the proposed 138 kV interconnection did not identify any steady-state overloads or voltage violations in addition to the C1C2 Phase II study.
- C. Replace Table 11.1 with the table below to reflect the revised scope of work for the PTO's Interconnection Facilities:
1. Install 500' of 1-636 ACSS/AW per phase with one deadend attachment at the rack
 2. Install two (2) 500' spans of overhead ground wire with one deadend attachment per span at the rack
 3. Install 500' of fiber optic communication cable
 4. Install one (1) 138 kV deadend structure
 5. Install two (2) 138 kV disconnect switches
 6. Install one (1) 138 kV circuit breaker
 7. Install associated relaying
- D. Replace Table 11.1 with the table below to reflect the corresponding changes in cost for the revised scope of work for Interconnection Facilities and Network Upgrades.
1. The PTO's Interconnection Facilities cost estimate for the Project changed from [REDACTED] to [REDACTED].
 2. The Reliability Network Upgrades, needed for physical interconnection, cost estimate for the Project changed from [REDACTED] to [REDACTED].
 3. The total estimated cost changed from [REDACTED] to [REDACTED].

The remainder of the Phase II study remains unchanged.

Table 11.1: Upgrades, Estimated Costs, and Estimated Time to Construct Summary

Type of Upgrade	Upgrade		Cost Allocation Factor	Estimated Cost x 1,000 <i>(Note 1)</i>	Estimated Time to Construct <i>(Note 2)</i>
<p>PTO's Interconnection Facilities <i>(Note 7)</i></p>	<p>Extend gen-tie from the POI at the 138 kV bus at Carlton Hills Substation the PTO property line</p>	<ul style="list-style-type: none"> • Install 500' of 1-636 ACSS/AW per phase with one deadend attachment at the rack • Install two (2) 500' spans of overhead ground wire with one deadend attachment per span at the rack • Install 500' of fiber optic communication cable • Install one (1) 138 kV deadend structure • Install two (2) 138 kV disconnect switches • Install one (1) 138 kV circuit breaker • Install associated relaying 	100%		12 Months
<p>Reliability Network Upgrades</p>	<p>Construct 138 kV bus extension at Carlton Hills Substation</p>	<ul style="list-style-type: none"> • Construct 138 kV bus extension at Carlton Hills Substation • Install one (1) disconnect switch 	100%		12 Months
	<p>Implement an SPS to protect Bernardo-Felicita Tap 69 kV line for N-2 of</p>	<p>SDG&E protection and communication equipment for Bernardo Substation, Escondido Substation, and Palomar Energy <i>(Note 5)</i></p>	6%		12 Months
	<p>Escondido-Palomar Energy 230 kV lines #1 and #2 <i>(Note 3)</i></p>	<p>Protection and communication equipment to interface between SDG&E and project (included in Mission-Old Town SPS cost) <i>(Note 6)</i></p>	100%		-
	<p>Implement an SPS to protect Mission-Old Town 230 kV line for N-2 contingencies</p>	<p>SDG&E protection and communication equipment for Mission Substation, Old Town Substation, and Silvergate Substation <i>(Note 5)</i></p>	8%		12 Months
	<p><i>(Note 3)</i></p>	<p>Protection and communication equipment to interface between SDG&E and project <i>(Note 6)</i></p>	100%		12 Months

Type of Upgrade	Upgrade		Cost Allocation Factor	Estimated Cost x 1,000 (Note 1)	Estimated Time to Construct (Note 2)
Delivery Network Upgrades	Reconductor Escondido-Palomar Energy 230 kV lines #1 and #2	<ul style="list-style-type: none"> Reconductor the spans of 605 ACSS/AW to 900 ACSS/AW on Escondido-Palomar Energy 230 kV lines #1 and #2 Install new cross arms for 230 kV pole Z202015 Relocate two overhead 69 kV circuits and convert to underground Remove one existing 69 kV cable pole, extend the underground trench package 600 feet into the substation, remove cable and splice in new cable, terminate at two underground rack positions in Escondido Substation Install 8-230 kV disconnects and adjust relaying at Escondido Substation 	10%	[REDACTED]	12 Months
	Reconductor Friars-Doulet Tap 138 kV line	<ul style="list-style-type: none"> Reconductor 10,500 feet of 400 MCM with 636 ACSR/AW Reconductor 1750 AL underground cable in the substation getaways to 1750 CU 	30%		12 Months
Total					12 Months

Notes for Table 11.1:

- Note 1: Estimated costs in "as year spent" dollars and in thousands of \$ dollars, excluding Allowance for Funds Used During Construction (AFUDC). Estimated costs include land purchases and licensing/permitting costs, when appropriate.
- Note 2: Time to construct estimates include time for licensing/permitting, when appropriate. The estimated time to construct is for a typical project; construction duration may change due to the number of projects simultaneously in construction. Multiple projects impact resources, system outage availability, and environmental windows of construction. A key assumption is SDG&E will need to obtain CPUC licensing and regulatory approvals prior to design, procurement, and construction of the proposed facilities. The time to construct is not cumulative.
- Note 3: Per CAISO guidelines, all Special Protection Systems are classified as Reliability Network Upgrades because their cost is less than [REDACTED] per project. This is to prevent overburdening of CAISO's congestion management system which can increase processing time to a point that could create reliability concerns.
- Note 4: The existing Imperial Valley SPS protects SDG&E, CFE, and IID following various N-1 and N-2 contingencies. All new SPSs and modifications to existing SPSs are subject to review by Affected System Operators, members of the Imperial Valley RAS Technical Committee, and review and approval by the WECC RASRS.
- Note 5: The SPS cost includes the equipment on the PTO's system. This is a one-time setup and equipment cost. The SPS cost does not include any control, protection, and/or fiber-optic communication costs at the project's facility.
- Note 6: The SPS cost includes project-specific equipment required on the PTO's system for interface with the project, as well as equipment provided to the project for installation at the project's facility. Additional SPSs would require updated logic, but minimal/no cost.
- Note 7: The Interconnection Customer is obligated to fund these upgrades and will not be reimbursed.

ATTACHMENT C

**GENERATOR INTERCONNECTION PROCEDURES:
DELIVERABILITY REQUIREMENTS FOR CLUSTERS 1-4**

**CLUSTER 1 AND 2 DELIVERABILITY ANALYSIS WITHOUT
EXPENSIVE AND LONG-LEAD NETWORK UPGRADES**

This page intentionally left blank.



Technical Bulletin

Generator Interconnection Procedures:
Deliverability Requirements for Clusters 1-4

January 31, 2012

Revised February 2, 2012

Market & Infrastructure Development

Technical Bulletin

Generator Interconnection Procedures: Deliverability Requirements for Clusters 1-4

Table of Contents

1	Executive Summary	3
2	Introduction	4
3	Cluster 1 and 2 approach	5
3.1	Technical details of the GIP Phase II study reassessment	6
3.1.1	Criteria for identifying upgrades to be removed	7
3.1.2	Application of the criteria to clusters 1 and 2	8
3.2	Providing Phase II addenda to cluster 1 and 2 projects	10
3.3	Impacts of over-building of generation in an area	10
3.3.1	Annual assessment of net qualifying capacity	11
3.3.2	Additional transmission expansion through the TPP	12
4	Cluster 3 and 4 approach	12

Generator Interconnection Procedures: Deliverability Requirements for Clusters 1-4

1 Executive Summary

This technical bulletin:

1. Describes the ISO's approach for determining the delivery network upgrades (DNU) for which interconnection customers in clusters 1 through 4 of the ISO's generation interconnection queue will be responsible, in accordance with the generator interconnection procedures (GIP) as specified in the ISO tariff;
2. Identifies those DNU that were determined to be required in the GIP Phase II studies for cluster 1 and 2 projects and will, as a result of the approach described herein, no longer be required for these projects to obtain full capacity deliverability status and execute generator interconnection agreements (GIA) on that basis;
3. Provides estimates of the amount of full capacity deliverability status generation that the ISO-controlled grid can support (in addition to generation already in operation) in each electrical area of the grid affected by the removal of the DNU described above;
4. Identifies additional network upgrades that were assumed in performing the GIP Phase II studies for clusters 1 and 2 but were not included for developing estimates of the MW amount of full capacity deliverability status generation the grid can support in affected electrical areas, in order to minimize the possibility of over-estimating grid capacity in such areas; and
5. Describes how the ISO will address situations, should they arise as a consequence of the approach described herein, where the MW amount of full capacity deliverability status generation in commercial operation in an electrical area of the grid exceeds or is expected to exceed the amount of net qualifying capacity (NQC) that the grid can support in that area.

Simultaneous with or shortly after the release of this technical bulletin, the ISO will provide each cluster 1 and 2 interconnection customer with an addendum to its Phase II Interconnection Study Report, which will specify the updated network upgrade and cost estimation information to be placed in the interconnection customer's GIA. The ISO agrees to provide cluster 1 and 2 interconnection customers an additional 30 days to execute their GIAs beyond the current deadlines for GIA execution. Interconnection financial security posting deadlines as specified in the GIP will remain in effect.

Concurrently with this technical bulletin, the ISO is posting a technical report providing further details on the results presented in section 3 of this paper with regard to cluster 1 and 2 projects. **After posting this technical bulletin on January 31, the ISO discovered a discrepancy between some of the results reported in section 3.1.2 of this document and the accompanying technical report, the latter of which is correct. The ISO therefore corrected the technical bulletin and is**

posting this revised version so that the material in section 3.1.2 is now consistent with the corresponding material reported in the technical report.

2 Introduction

On October 31, 2011, the ISO posted the “Draft Discussion Paper: Cluster 1 and 2 Deliverability Concerns, Provision of Additional Information.”¹ That paper was prompted by concerns many developers of renewable generation projects and other stakeholders had expressed regarding the impacts of the large cluster size on the ISO network upgrade requirements for full capacity deliverability status (the “delivery network upgrades” or “DNU”). In particular, due to the large volume of projects in these clusters, the ISO’s interconnection studies showed that full capacity deliverability status required costly DNU in some areas that would take until the latter part of this decade to complete. Developers and other parties complained that the high cost and the long wait to obtain full capacity deliverability status were preventing projects from obtaining power purchase agreements (PPAs) and project financing.

In the October 31 paper the ISO provided information it believed would help address the above concerns. The paper provided engineering estimates of the amount of new generation that could achieve full capacity deliverability status without requiring the high-cost, long lead-time DNU. The concept was that based on this information, load-serving entities (LSEs) could avoid triggering the need for these problematic upgrades by limiting their procurement of renewable PPAs in certain areas of the grid to stay within the amounts indicated by the ISO.

The ISO held a stakeholder conference call to discuss the October 31 paper and then received written comments and other input from stakeholders.² The main message of this input was that provision of the MW threshold information was not sufficient to enable bilateral contracting and project financing to proceed. The remaining problem was that any given interconnection customer could not be sufficiently certain that the high-cost long lead-time DNU would not in fact be triggered, because the outcome ultimately depended on factors outside that interconnection customer’s control, specifically, decisions by LSEs to execute PPAs with a large amount of other projects in the same area. This meant that when it came time for a project developer to submit a bid into an LSE’s procurement request for offer (RFO) or to negotiate its generation interconnection agreement (GIA), the developer would not know its transmission cost with sufficient certainty either for the RFO process or for project financing.

Based on this input and further consideration of possible alternatives, the ISO developed a more effective way to address the identified concerns, and described it in a revised discussion paper posted on January 10, 2012, which was discussed at a stakeholder meeting on January 17.³

¹ <http://www.caiso.com/Documents/DraftDiscussionPaper-Cluster1-2DeliverabilityConcerns.pdf>

² See <http://www.caiso.com/informed/Pages/StakeholderProcesses/GeneratorInterconnectionProceduresCluster1-2DeliverabilityConcerns.aspx> for information on the ISO’s stakeholder efforts with respect to cluster 1 and 2 deliverability concerns.

³ http://www.caiso.com/Documents/RevisedDiscussionPaper-GenerationInterconnectionProceduresCluster1_2DeliverabilityConcerns.pdf

That approach, which is now finalized in the present technical bulletin, involves revising the DNU requirements for cluster 1 and 2 projects that were originally identified in the GIP Phase II studies to eliminate the high-cost, long lead-time DNU that have impeded PPA and GIA negotiation and project financing. The rationale for eliminating these upgrades is the commonly accepted fact that the generation interconnection queue contains three to four times as much generating capacity as is needed and could be commercially viable. If the actual financing, construction and commercial operation of new generation remains in line with the amount actually needed to meet renewable targets and load growth, these eliminated transmission facilities will most likely not be needed, and therefore should not be included in the network upgrade requirements or cost estimates of the generation projects.

The approach described here does not fully eliminate the possibility that new generation could develop in a given electrical area of the grid in a total amount that exceeds the capability of the grid to support full capacity deliverability status for all projects in that area. Indeed, this could occur in a particular area of the grid, even though the total amount of development system-wide does not exceed what is needed to meet renewable targets. Under the approach described here, such an outcome (which would be apparent from approved PPAs and generation project construction activities well before all the projects achieve commercial operation) could lead the ISO to identify additional public policy-driven transmission elements in the transmission planning process, but would not cause the generation projects to face DNU costs beyond what were specified in their GIAs. This approach thus eliminates uncertainty for project developers about potential increases in financial posting or cost responsibilities if a need for additional network upgrades is triggered.

One remaining risk that LSEs and developers would need to recognize is the potential for some generating resources in this circumstance to receive less net qualifying capacity (NQC) for one or more resource adequacy compliance years than the full value of their deliverability status would indicate. This risk exists today due to the distinction in the ISO tariff between a resource's deliverability status, which is a stable attribute of the resource, and its NQC, which is determined annually through an ISO deliverability analysis in advance of each resource adequacy (RA) compliance year.

Section 3 of this bulletin discusses the approach with regard to clusters 1 and 2. Since the ISO has completed the analysis of the results for projects in these clusters, section 3 specifies the DNU that will be removed from the requirements that were stated in the previously-released GIP Phase II study results for these projects, as well as estimates of the amount of full capacity deliverability status generation the grid can support in electrical areas affected by the removal of these DNU. Section 4 of this technical bulletin explains how the ISO will use the approach for cluster 3 and 4 projects.

3 Cluster 1 and 2 approach

The ISO will reassess the cluster 1 and 2 Phase II study results with regard to those delivery network upgrades (DNU) that: (1) are costly and will require large postings by cluster 1 and 2 projects, (2) will take many years to be built, thus delaying deliverability for these projects and

adversely affecting their ability to provide RA capacity as required by their PPAs, and (3) are not likely to be needed based on the amount of new generation expected to actually receive PPAs and become commercially viable. The reassessment will assume that the amount of new generating capacity in each study area will not exceed the amount that will be deliverable based on the transmission system as reflected in the 2011/2012 transmission plan without requiring the problematic DNU as characterized above. For example, in the Desert Area⁴ the ISO will assume that no more than about 9,300 MW of new generating capacity will actually achieve commercial operation out of the roughly 11,300 MW in the existing queue (up to and including clusters 1 and 2). On this basis the ISO will provide addenda to the cluster 1 and 2 Phase II study results, which will provide to the affected cluster 1 and 2 generation projects the reduced DNU requirements and associated cost responsibilities. Those interconnection customers will then be able to proceed to negotiate GIAs that provide their requested deliverability status and do not require the problematic DNU. Additional technical detail on this element of the proposal is provided in the next sub-section.

One potential outcome of this approach is that, if more than the assumed amount of generation in any given study area actually gets PPAs and achieves commercial operation (e.g., if more than about 9,300 MW gets built and comes on-line in the Desert Area), the transmission grid as planned at the time the cluster 1 and 2 projects signed GIAs would not actually support the full capacity deliverability status of all projects. Section 3.3 below discusses the implications of this situation if it occurs.

3.1 Technical details of the GIP Phase II study reassessment

This section describes two aspects of the technical reassessment of GIP Phase II study results. The first aspect is to specify criteria for identifying which DNU that resulted from the current cluster's Phase II study should be removed for purposes of determining each generation project's cost responsibility and related provisions of its GIA. The second aspect is to estimate the amount of full capacity deliverability status generation that the grid can support in each grid area affected by the removal of these DNU. For this purpose the ISO will also consider whether any network upgrades associated with earlier queued generation projects, and those generation projects as well, should be removed from the assessment of available deliverability. This is important because, in areas where there is significant risk that the generation projects driving the need for these previously identified network upgrades will not be completed, the ISO might over-estimate the amount of available deliverability by including these upgrades.

The criteria specified here for cluster 1 and 2 for the purposes described above will be applied again in the context of clusters 3 and 4, as discussed in section 4 of this technical bulletin.

⁴ The Desert Area refers to generating resources electrically located in the following renewable energy zones: Pisgah, Mountain Pass, Nevada C, New Mexico, Palm Springs, Riverside East, San Diego South, Imperial, and Arizona.

3.1.1 Criteria for identifying upgrades to be removed

A delivery network upgrade originally identified during the GIP Phase II interconnection study process for the current cluster (i.e., clusters 1 and 2) may be removed from the Phase II study results if the upgrade is not needed in the current transmission plan and satisfies at least one of the following criteria:

- (a) The network upgrade consists of new transmission lines 200 kV or above, and has capital costs of \$100 million or greater; or
- (b) The network upgrade has a capital cost of \$200 million or more.

For purposes of this assessment, “not needed in the current transmission plan” entails all of the following:

1. The upgrade was not modeled in the base case for the current planning cycle;
2. The upgrade was not approved in the final comprehensive transmission plan for the current planning cycle; and
3. The need for the upgrade was driven by a quantity of new generation that is far in excess of the amount needed to achieve the public policy requirement specified as an objective in the current planning cycle.

The specific network upgrades associated with cluster 1 and 2 projects that meet these criteria are identified in the next section. The ISO will remove them from the Phase II interconnection study DNU requirements for clusters 1 and 2, and will reflect their removal in the financial posting requirements for these generation projects and in the terms of their GIAs.

For purposes of calculating the amount of deliverability that is available without triggering the DNU identified under the criteria above, the ISO may also remove a network upgrade that was needed by earlier-queued generation projects and was assumed in-service in the original GIP Phase II interconnection study for the current cluster, if the upgrade is not needed in the current transmission plan and satisfies at least one of criteria (a) and (b), plus criterion (c):

- (a) The upgrade consists of new transmission lines 200 kV or above, and has capital costs of \$100 million or greater; or
- (b) The upgrade has a capital cost of \$200 million or more; and
- (c) Funding for the network upgrade is at risk because the generation project responsible for its funding or for triggering the need is at risk of not being developed. The ISO will determine such risk based on publicly available information regarding permitting, commercial issues and delays in development timeline.

The ISO would, of course, also remove the earlier queued generation projects associated with any network upgrades removed from the deliverability study on this basis and would reflect their removal in the supplementary deliverability study results for cluster 1 and 2 projects.

It is important to emphasize that the removal of certain earlier queued generation projects and the network upgrades associated with them is only for the purpose of estimating the amount of new full capacity deliverability status generation the grid can support in the electrical area in

question without additional upgrades. The removal of these network upgrades and associated generation projects for purposes of this estimation has no impact on the status of the upgrades, the earlier-queued generation projects or their GIAs. The ISO is removing the network upgrades for this estimation because not to do so could lead to unrealistic over-estimation of the amount of deliverability the grid will be able to support, given current status information indicating reasonable doubt that the generation projects will be completed.

Once the two groups of delivery network upgrades are removed from the assumptions for this aspect of the approach, the ISO will determine how much deliverability the network will provide in each study area without these upgrades.

3.1.2 Application of the criteria to clusters 1 and 2

Applying the criteria above for identifying upgrades to be removed from the cluster 1 and 2 deliverability studies leads to removal of the following network upgrades:

1. Mohave–Lugo 500 kV line loop-in Pisgah 500 kV Substation and series capacitor banks on both Pisgah–Nipton and Pisgah–Mohave 500 kV lines;
2. Colorado River–Red Bluff No.3 line; and
3. Red Bluff–Valley 500 kV line.

In addition, applying the criteria above for identifying upgrades associated with earlier queued generation projects for purposes of the estimation of available deliverability leads to the removal of the following:

4. Upgrade of Pisgah 230kV substation to 500kV substation, teardown of existing Pisgah – Lugo 230 kV No.1 line and replacement with new Pisgah – Lugo 500 kV No. 1 line, and Lugo–Eldorado 500kV line loop-in at Pisgah 500kV bus; and
5. Q72 and associated upgrades (dual 500 kV generation tie-lines connecting to SCE and SDG&E systems near Valley and Talega substations respectively).

The removal of these additional upgrades introduces additional deliverability constraints, which affect the amount of deliverability available in certain study areas, as described below.

Desert Area Constraints – Preliminary Results

The ISO performed a deliverability analysis following its existing study procedures to determine how much of cluster 1 and 2 and earlier queued generation would be deliverable without the DNU listed above. The ISO queue up to and including clusters 1 and 2 contains approximately 11,300 MW⁵ of generation in the Desert Area that will have significant flows across the deliverability constraints listed in the two tables below, for the SCE and SDG&E PTO service territories respectively. Of these, approximately 6,000 MW to 9,300 MW can be accommodated

⁵ The previous discussion paper stated this number as 12,000 MW. The reduction to 11,300 MW is due to project withdrawals and updates to the queue information. This change in the project modeling also affected the range of deliverable MW amounts slightly.

as fully deliverable without the need for the major upgrades listed above. As a comparison, the renewable resource portfolios under study in the 2011/2012 ISO transmission planning process have no more than approximately 5000 MW to 7000 MW of renewable generation that have significant flows across these constraints.

The following table lists all the deliverability constraints identified in the SCE area study.

Contingency	Limiting Facility
Normal condition	Lugo - Pisgah 230 kV No. 2
Lugo - Jasper 230 kV No. 1 & Lugo - Pisgah 230 kV No. 2	Pisgah - Cima - Eldorado 230 kV No. 1
	Pisgah - Eldorado 230 kV No. 2
	Kramer - Lockhart 230 kV No. 1
Devers - Red Bluff 500 kV No. 1 & No. 2	N. Gila - Imperial Valley 500 kV No. 1
	Lugo - Victorville 500 kV No. 1
Red Bluff - Colorado River 500 kV No. 1 & No. 2	N. Gila - Imperial Valley 500 kV No. 1
	Lugo - Victorville 500 kV No. 1

The ISO queue contains approximately 3,800 MW of generation that have significant flows across the SDG&E system deliverability constraint identified below, of which approximately 2,400 MW to 3,200 MW can be accommodated as fully deliverable without the need for major upgrades. As a comparison, the renewable resource portfolios under study in the 2011/2012 ISO transmission planning process have no more than approximately 1,000 MW to 2,000 MW of generation with significant flows across this constraint.

The following table lists all the deliverability constraints identified in the SDG&E area study.

Contingency	Limiting Facility
Normal condition	Path 43 (North of SONGS) path rating

The amount of MW that would be deliverable is stated as a range rather than a single amount because the exact amount depends on which of the generation projects in the queue actually proceed to commercial operation, as different project locations will have different flow impacts on the constraints. For the Desert Area, an additional source of uncertainty exists since the existing series capacitor at Lugo substation on the Eldorado/Nipton-Lugo 500 kV line has a low rating and is normally by-passed. In the study the ISO initially assumed that the Lugo series cap was bypassed, and then performed a sensitivity study with the series cap upgraded and in-service. For the San Diego area, an additional source of uncertainty regarding the exact amount of deliverable new generation is the uncertainty about how Encina units 4, 5 and GT (644 MW total) and Cabrillo II generation (188 MW) will address the once-through cooling requirements; i.e., whether they will retire due to once-through cooling compliance requirements and site lease

expirations, or will be retrofitted, repowered or renewed. If these units choose to be retrofitted, repowered, or renewed then their deliverability will need to be preserved. These uncertainties are reflected in the ranges provided above for the amount of available deliverability.

3.2 Providing Phase II addenda to cluster 1 and 2 projects

The ISO will issue an addendum to each cluster 1 and 2 interconnection customer's Phase II Interconnection Study Report. The addendum will provide updates to the report to identify the final DNU requirements based upon stated levels of MW generating capacity additions in electrical areas of the ISO-controlled grid, as described above. The report addenda will not result in increased costs or delayed in-service dates for updated DNU requirements. To the contrary, it is expected that any changes in the updated analysis will identify fewer DNU and/or earlier in-service dates for such upgrades, and thus, are expected to reduce interconnection customer maximum cost responsibility for such upgrades. Accordingly, issuance of these addenda will not result in a change in the date for interconnection customers to make the second posting of interconnection financial security. The updated DNU identified in the report addendum shall be the operative DNU for purposes of setting the interconnection customer's cost responsibility and to be specified in the interconnection customer's GIA. Interconnection customers will be afforded an additional 30 calendar day period to review any amendments to their GIA or revised draft GIA setting forth the updated DNU requirements.

3.3 Impacts of over-building of generation in an area

This section discusses two possible implications in cases where the amount of new generating capacity that actually achieves commercial operation in a particular study area is greater than the amount that was anticipated in reassessing the Phase II interconnection study results and executing GIAs based on the revised results. If this happens, the amount of new generating capacity that was designated as full capacity deliverability status and has executed GIAs will exceed the amount of deliverability that is supported by the transmission system assumed at that time. The potential for this situation exists by design, because in revising the Phase II study results the ISO explicitly assumed that the amount of new generation that will actually achieve commercial operation in the study area is below the threshold that triggers the removed DNU. Clearly, if more new generation actually proceeds and achieves commercial operation, that assumption is no longer valid.

It is important to recognize that LSEs and their regulatory authorities can minimize the likelihood of this situation occurring by coordinating their procurement activities so as to avoid aggregate procurement that exceeds the threshold to trigger the removed DNU in any grid area. The information the ISO provides under this approach will include the specific DNU that were removed from the initial Phase II study results, and the estimated amount of new generating capacity that would be fully deliverable without the removed DNU (equivalent to the threshold of new generating capacity that would trigger the need for the removed DNU).

The first implication is the potential for resources to receive lower NQC values in the ISO's annual NQC assessment than the full equivalent to their full capacity deliverability status. This would mean that the maximum amount of resource adequacy capacity the resource could provide for the coming year would be less than its full capacity-based qualifying capacity. The second implication is that the situation could provide the basis for the ISO to identify and approve new transmission upgrades in the ISO transmission planning process (TPP). These two possible outcomes are not mutually exclusive. Even if the ISO does approve new transmission to mitigate the reduction of NQC in an area, the annual reductions in NQC would need to be applied until the new transmission facilities are placed in service. These two implications are discussed in more detail in the two sub-sections below.

3.3.1 Annual assessment of net qualifying capacity

The ISO's annual NQC process is governed by section 40 of the ISO tariff. Pursuant to section 40.4.6.1 of the tariff, the ISO determines NQC values for generating resources in each grid area that are consistent with the capability of the transmission system in that area. The ISO performs this determination roughly six months prior to the start of each resource adequacy compliance year (i.e., each calendar year), and it is based on the transmission network and the generating facilities expected to be in service by the start of the year. The implication of this assessment is that resources in an area that is "over-subscribed" in the sense of this section may receive NQC values that are lower than their full capacity deliverability status and their qualifying capacity (QC) values would imply.

Under tariff section 40.4.6.1 such NQC adjustments, if needed, could be applied to all generating resources eligible for NQC for the upcoming resource adequacy year that have significant flow impacts on the binding transmission constraints. To best align with the approach described in this bulletin for determining required DNU for cluster 1 and 2 projects, the ISO will distinguish between two tiers of generating resources – "new" and "existing" – in applying any needed NQC adjustments. The ISO will first apply NQC adjustments only to "new" generating resources that have at least five percent flow distribution factor on one or more of the relevant binding constraints. However, if the amount of generation in this first tier is not sufficient to relieve the binding constraints, the ISO will then utilize the second tier and apply NQC adjustments to both "new" and "existing" generation with at least five percent flow factor on a binding constraint.

For purposes of these potential NQC adjustments, "existing" generation is defined to include resources that either are already in commercial operation or have executed bilateral contracts (specifically, a PPA or an RA contract committing the resource to provide RA capacity in an amount equivalent to its full capacity deliverability status in the GIP) no later than February 29, 2012. All other resources will be classified as "new." For a resource not currently in commercial operation to be classified as "existing" the resource owner and the counterparty to the executed bilateral contract will be required to submit an affidavit (by a company representative with authority to bind the interconnection customer) attesting to the existence of the contract for sale/purchase of its electrical output and its relevant provisions, in accordance with a process the ISO will specify in the Business Practices Manual for Reliability Requirements. The ISO will

start the Business Practices Manual change management process (a 60-day process) to outline the affidavit process and form of affidavit soon after this technical bulletin is posted, and parties will have 30 days after the relevant Business Practices Manual provisions are finalized to submit the required affidavits to the ISO.

In applying NQC adjustments to resources in a constrained area of the grid, the ISO will utilize a “weighted least squares algorithm” similar to the algorithm used in the allocation of congestion revenue rights to eligible load-serving entities.⁶ The weighted least squares algorithm is an equitable and effective way to distribute the NQC reductions over all resources that have flow factors above the five percent threshold, rather than concentrating such reductions on only the resources that have the highest flow factors. The ISO will include the technical details for this algorithm as applied to NQC adjustments in the Business Practices Manual for Reliability Requirements.

3.3.2 Additional transmission expansion through the TPP

Another potential consequence if more than the assumed amount of generation actually develops in any given area is that the ISO could approve additional policy-driven transmission in the TPP. This would occur through an expansion of the base resource portfolio formulated for the public policy TPP assessment to reflect the increased amount of generating capacity with full capacity deliverability status that is being developed in the area. Under the ISO’s existing tariff provisions, any such transmission elements would be subject to a solicitation process in which non-incumbent transmission developers could compete to build and own the policy-driven transmission element (with certain exceptions per tariff section 24.5.2). Even if the ISO does approve additional transmission under the TPP to provide the needed capacity for all the full capacity resources in the area, it will probably still be necessary to apply NQC adjustments for the years before the new transmission facilities are placed in service.

4 Cluster 3 and 4 approach

The GIP Phase II process for clusters 3 and 4 will be comparable to the approach described above for clusters 1 and 2. The main difference to be noted is the fact that the Phase II process for clusters 3 and 4 has not yet begun and can therefore be performed so as to provide results that reflect the approach described in this bulletin, rather than requiring report addenda as in the case of clusters 1 and 2. The Phase II study for clusters 3 and 4 will maintain the currently planned Phase II study time line (i.e., start in April 2012 and complete around end of October).

The following steps describe the cluster 3 and 4 approach.

1. Adjust the study assumptions regarding the prior queue (up through cluster 2) to reflect the removal of the problematic DNU that were removed in the revised cluster 1 and 2

⁶ The Business Practices Manual for Congestion Revenue Rights, starting on page 101, provides technical details on the weighted least squares algorithm used in that context, and can be found at: <https://bpm.caiso.com/bpm/bpm/version/000000000000152>

GIP Phase II study results and the amounts of deliverable generation that are consistent with the removal of those DNU.

2. Apply the full amount of cluster 3 and 4 generation initially, to determine the transmission required to interconnect all projects in these clusters at their requested deliverability status.
3. As was done for clusters 1 and 2 and using the same criteria described in section 2.1.1 above, identify the DNU that can be removed from the initial cluster 3 and 4 Phase II results. Determine the amount of deliverability in each study area that is supported by the revised results without requiring the problematic DNU. This information would be made available to LSEs and their regulatory authorities, along with cost information about the DNU that were removed from the results, to inform procurement decisions.
4. Issue Phase II study reports to cluster 3 and 4 interconnection customers based on results of the previous step, so that they can proceed to negotiate GIAs and make their required postings without having to be concerned with the problematic delivery DNU.

As with the cluster 1 and 2 approach, the risk remains that more generating capacity than was assumed will actually be built and achieve commercial operation in a particular study area and will require the DNU that were removed from the revised GIP Phase II study reports or other new transmission in the area. The discussion of how the ISO will address such situations in the context of clusters 1 and 2 above applies equally to clusters 3 and 4.

Cluster 1 & 2 Deliverability Analysis without Expensive and Long-Lead Network Upgrades

Objective

This analysis was performed pursuant to the October 31, 2012 Technical Bulletin on Cluster 1-4 Deliverability Procedures and for the sole purpose of applying those procedures to Cluster 1 & 2. The following projects and upgrades met the criteria for removal:

- Mohave–Lugo 500 kV line loop-in at Pisgah 500 kV Substation and series capacitor banks on both Pisgah–Nipton and Pisgah–Mohave 500 kV lines
- A 31 miles of new Colorado River – Red Bluff No.3 line
- A 103 miles of new Red Bluff – Valley 500 kV line with series cap banks
- Upgrade of Pisgah 230kV substation to 500kV substation and Lugo – Eldorado 500kV line loop-in at Pisgah 500kV bus
- Tearing down Pisgah – Lugo 230kV No. 2 line and the new Pisgah – Lugo 500kV No. 1 line
- Q72 and associated upgrades

The following network upgrades and modifications were modeled due to the removal of the above elements:

- The 3rd Lugo 500/230 kV transformer bank. The transformer bank is required for the Cluster 1 & 2 projects in the North of Lugo area. In addition, the deliverability sensitivity study on the 2011/12 Base 33% renewable portfolio has identified the need for the transformer bank if Pisgah 500kV upgrade were not built.
- New Coolwater – Jasper – Lugo 230 kV line. The line is required for Serial Group projects that have signed LGIA (Q125 and Q135), and Q125 has a CPUC approved PPA. The new Jasper – Lugo line is built by tearing down portion of the existing Lugo – Pisgah 230 kV No. 1 line. In this study we replace Lugo – Pisgah 230 kV No. 1 line with Lugo – Jasper 230 kV line and Jasper – Pisgah 230 kV line. The Lugo – Jasper 230 kV line is rebuilt with higher rating and the Jasper – Pisgah 230 kV line has the same rating as the existing line.
- Lugo – Eldorado 500kV loop-in at Nipton 500 kV substation is required to interconnect a Serial Group project Q126 and will be modeled. There are two existing series capacitors on the Lugo – Eldorado 500 kV line. The study assumes that the Eldorado series capacitor is replaced by a new series capacitor at Nipton to maintain the same level of compensation as the existing line. The existing series capacitor at Lugo substation has a low rating and is normally by-passed. In this study the Lugo series capacitor is initially assumed bypassed. Then a sensitivity study is performed with this series capacitor upgraded.

The figure below shows the transmission system to be modeled. The four shaded oval areas in the diagram below represent deliverability constraints and the general location of four groups of generation affected by those constraints.

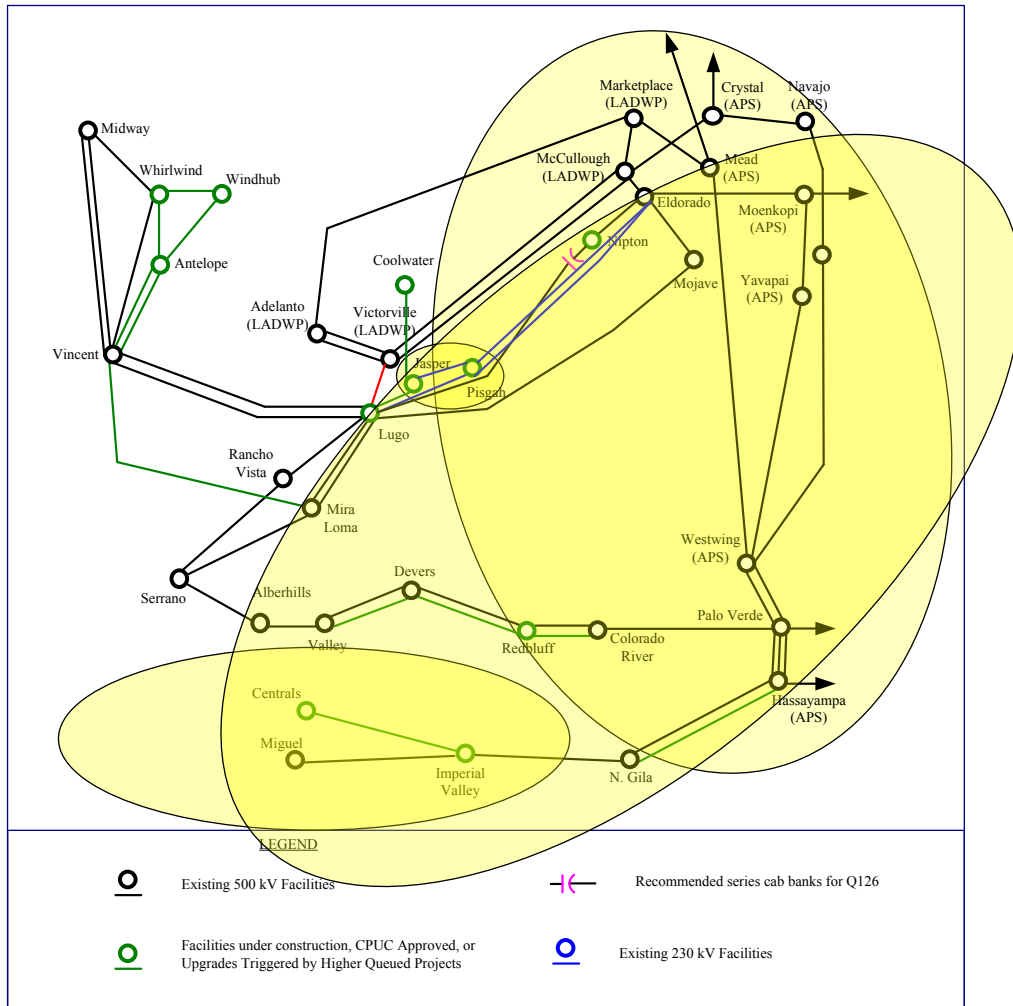

Summary of Results – Desert¹ Area Constraints

Table 1 provides a very high level summary of the range of MWs that are deliverable without the delivery network upgrades identified above. Given that there is approximately 11,300 MW of generation in the ISO queue that significantly flow across the deliverability constraints described in detail later, approximately 6,000 MW to 7,900 MW can be accommodated as fully deliverable without the need for the major upgrades listed above. Approximately 8,100 MW to 9,300 MW can be accommodated as fully deliverable with the series capacitor in the Lugo – Nipton 500kV line upgraded. As a comparison, the renewable portfolios under study in the 2011/2012 ISO transmission planning process have no more than approximately 7000 MW of renewable generation that significantly flow across these constraints.

¹ The Desert Area refers to generating resources electrically located in the following renewable energy zones: Pisgah, Mountain Pass, Nevada C, New Mexico, Palm Springs, Riverside East, San Diego South, Imperial, and Arizona.

Table 1. Summary of Results – SCE Area

Deliverable MW in Desert area	Low End of Range	High End of Range
Without upgrading Nipton – Lugo series cap at Lugo	6058	7887
With upgrading Nipton – Lugo series cap at Lugo	8177	9302

Summary of Results – SDG&E Area Constraint

Table 2 provides the approximate number of MWs that are deliverable if Q72 and its associated transmission upgrades are not in-service. Given that there is approximately 3,800 MW of generation in the ISO queue that significantly flow across the deliverability constraint described in detail later, approximately 2,400 MW to 3,200 MW can be accommodated as fully deliverable without the need for major upgrades similar to Q72 upgrades. As a comparison, the renewable portfolios under study in the 2011/2012 ISO transmission planning process have no more than approximately 1,000 MW to 2,000 MW of generation that significantly flow across the constraint.

Table 2. Summary of Results – SDG&E Area

	Low End of Range	High End of Range
Deliverable MW in SDG&E area	2400	3200

Methodology and Assumptions

The total generation in the generation interconnection queue up to Cluster 1 & 2 exceeds the deliverability provided by the transmission system. Some of the generation projects were removed to determine the deliverable amount of MW in the affected areas. The amount of deliverable MW depends on where the generator projects are removed. Therefore a range, instead of a fixed number, of the deliverable MW was identified in the analysis.

The analysis consisted of the following major steps for the Desert area study (similar assumptions are used for the SDG&E area study):

1. The Cluster 1 & 2 East of Lugo (EOL) base case (SDG&E area base case for the SDG&E area study) was modified to represent the transmission system described above.
2. Ran deliverability assessment and identified all the deliverability constraints.
3. Built minimum generation withdrawal scenario based on the deliverability study results.
4. Tested deliverability for the minimum generation withdrawal scenario. Step 3 and 4 were repeated until there were no more deliverability constraints identified.
5. Built maximum generation withdrawal scenario based on the deliverability study results.
6. Tested deliverability for the maximum generation withdrawal scenario. Step 5 and 6 were repeated until there were no more deliverability constraints identified.

Two scenarios associated with the series capacitor bank in the Lugo – Nipton 500kV line at Lugo Substation were studied.

- Scenario A: bypass the Lugo series capacitor in the Lugo – Nipton line
- Scenario B: upgrade the Lugo series capacitor in the Lugo – Nipton line

Results – Desert Area

Table 3 and 4 list all the deliverability constraints identified in the Desert area study.

Table 3. Deliverability constraints – Scenario A

Contingency	Limiting Facility
Normal condition	Lugo - Pisgah 230 kV No. 2
Lugo - Jasper 230 kV No. 1 & Lugo - Pisgah 230 kV No. 2	Pisgah - Cima - Eldorado 230 kV No. 1
	Pisgah - Eldorado 230 kV No. 2
	Kramer - Lockhart 230 kV No. 1
Devers - Red Bluff 500 kV No. 1 & No. 2	N. Gila - Imperial Valley 500 kV No. 1
	Lugo - Victorville 500 kV No. 1
Red Bluff - Colorado River 500 kV No. 1 & No. 2	N. Gila - Imperial Valley 500 kV No. 1
	Lugo - Victorville 500 kV No. 1

Table 4. Deliverability constraints – Scenario B

Contingency	Limiting Facility
Normal condition	Lugo - Pisgah 230 kV No. 2
Lugo - Jasper 230 kV No. 1 & Lugo - Pisgah 230 kV No. 2	Pisgah - Cima - Eldorado 230 kV No. 1
	Pisgah - Eldorado 230 kV No. 2
	Kramer - Lockhart 230 kV No. 1
Eldorado – Mohave 500 kV No. 1	Lugo – Nipton 500 kV No. 1
Palo Verde – Colorado River 500 kV No. 1	Lugo – Nipton 500 kV No. 1
Lugo – Victorville 500 kV No. 1	Eldorado – Nipton 500 kV No. 1
Lugo - Nipton 500 kV No. 1	Lugo – Victorville 500 kV No. 1
Devers - Red Bluff 500 kV No. 1 & No. 2	N. Gila - Imperial Valley 500 kV No. 1
Red Bluff - Colorado River 500 kV No. 1 & No. 2	N. Gila - Imperial Valley 500 kV No. 1
	Eldorado – Nipton 500kV No. 1

Lowest level of generation withdrawal need under Scenario A

Approximately 3420 MW generation are needed to withdraw:

- 600 MW in San Diego area
- 1250 MW at Pisgah
- 1570 MW in Riverside East area

The withdrawal amount at Pisgah is driven by the normal overload on Lugo – Pisgah 230 kV No. 2 line. The withdrawal amount in Riverside East area is driven by the emergency overload on the series capacitor in the N. Gila – Imperial Valley 500 kV line

Highest level of generation withdrawal need under Scenario A

Approximately 5249 MW generation are needed to withdraw if the withdrawals are not at the most effective locations:

- 600 MW in San Diego area
- 1650 MW at Pisgah
- 1070 MW in Riverside East area
- 1929 MW in Mountain Pass area

The withdrawal amount at Pisgah is driven by the normal overload on Lugo – Pisgah 230 kV No. 2 line. The withdrawal amounts in Riverside East area and Mountain Pass area are driven by the emergency rating on the series capacitor in the N. Gila – Imperial Valley 500 kV line

Lowest level of generation withdrawal need under Scenario B

Approximately 2005 MW generation are needed to withdraw:

- 600 MW in San Diego area
- 1250 MW at Pisgah
- 155 MW in Mountain Pass

The withdrawal amount at Pisgah is driven by the normal rating on Lugo – Pisgah 230 kV No. 2 line. The withdrawal amount in Mountain Pass area is driven by the emergency rating on the Eldorado – Nipton 500kV line and Lugo – Nipton 500 kV line.

Highest level of generation withdrawal need under Scenario B

Approximately 3130 MW generation are needed to withdraw if the withdrawals are not at the most effective locations:

- 600 MW in San Diego area
- 1650 MW at Pisgah
- 310 MW in Mountain Pass
- 570 MW in Riverside East area

The withdrawal amount at Pisgah is driven by the normal rating on Lugo – Pisgah 230 kV No. 2 line. The withdrawal amounts in Mountain Pass area and Riverside East area are driven by the emergency rating on the Eldorado – Nipton 500kV line and Lugo – Nipton 500 kV line.

Table 5 lists the combined set of proposed generation projects for all the deliverability constraints and Table 6 and 7 list the shift factors on the constraints. The dispatch of proposed generation by CREZ in the lowest level of withdrawal cases are also shown in Table 6 and 7.

Table 5. Generation Projects Contributing to the Desert Area Deliverability Constraints

Generation Projects Contributing to the SCE Area Deliverability Constraints			
Project Q#	POI	Pmax	CREZ
17	Colorado River 500kV	520	Riverside East (500 kV)
32	Boulevard 138 kV	201	San Diego South
58	Control 115 kV	62	Kramer
68	Pisgah 230kV	850	Pisgah
103	Border 69 kV	27	SDG&E Non-CREZ
124	Imperial Valley 230 kV	600	Imperial – SDG&E
126	Nipton 230kV	500	Mountain Pass
131	Ivanpah 230kV	100	Mountain Pass
135	Jasper 230kV	60	San Bernardino - Lucerne
146	Redbluff 230 kV	150	Riverside East (500 kV)
147	Redbluff 230 kV	400	Riverside East (500 kV)
150	Border 69 kV	47.4	SDG&E Non-CREZ
156	Jasper 230kV	201	San Bernardino - Lucerne
162	Ivanpah 230kV	114	Mountain Pass
163	Ivanpah 230kV	300	Mountain Pass
193	Colorado River 230kV	500	Riverside East (500 kV)
219	Colorado River 500kV	50	Riverside East (500 kV)
233	Ivanpah 230kV	200	Mountain Pass
240	Pisgah 230kV	400	Pisgah
241	Pisgah 230kV	400	Pisgah
294	Colorado River 230kV	1000	Riverside East (500 kV)
297	Neenach 66 kV	66	Tehachapi 230kV
365	Redbluff 230 kV	500	Riverside East (500 kV)
421	Blythe 161 kV	49.5	Riverside East (161 kV)
429	Imperial Valley 230 kV	100	Imperial - SDG&E
442	Imperial Valley 230 kV	125	Imperial - SDG&E
467	Primm 230kV	230	Mountain Pass
493	IV - Central 500kV	299	Imperial - SDG&E
502	Primm 230kV	20	Mountain Pass
503	Eldorado 230kV	155	Mountain Pass
510	Imperial Valley 230 kV	200	Imperial - SDG&E
512	Neenach 66 kV	26	Tehachapi 230kV
552	Jasper 230kV	60	San Bernardino - Lucerne
561	Imperial Valley 230 kV	200	Imperial - SDG&E
565	Miguel - Sycamore 230 kV	100	SDG&E Non-CREZ
574	Otay Mesa 230 kV	308	SDG&E Non-CREZ
576	Colorado River 230kV	485	Riverside East (500 kV)
588	Redbluff 230 kV	200	Riverside East (500 kV)

590	Imperial Valley 230 kV	150	Imperial - SDG&E
593	Mohave 500kV	310	Mountain Pass
608	Imperial Valley 230 kV	250	Imperial - SDG&E
106A	Boulevrd 138 kV	160	San Diego South
159A	ECO 230 kV	400	San Diego South
WDT190	Vestal 66 kV	49.9	SCE Non-CREZ
WDT235	Goleta 66 kV	49.9	SCE Non-CREZ
WDT315	Casa Diablo 34 kV	40.7	Kramer
WDT425	Vestal 66 kV	51	SCE Non-CREZ
WDT433	Vestal 66 kV	40	SCE Non-CREZ
Total MW		11307.4	

Table 6: Shift factors by CREZ – Scenario A

Shift Factors and Dispatch by CREZ (Nipton-Lugo series capacitors bypassed at Lugo)							
Limiting Facility		Lugo - Pisgah 230kV No. 2		N. Gila - IV 500kV		Lugo - Victorville 500kV line	
Contingency		Normal		Red Bluff - Devers No. 1 & No. 2		Red Bluff - Devers No. 1 & No. 2	
	PMAX	Shift Factors	PGEN	Shift Factors	PGEN	Shift Factors	PGEN
Pisgah	1650	0.31	340	0.06	272	<.05	272
San Bernardino - Lucerne	321	0.06	192.4	0.06	113.1	<.05	113.1
Riverside East (500 kV)	3805	<.05	896.8	0.26	609	0.19	869.5
Riverside East (161 kV)	49.5	<.05	0	<.05	0	0.10	0
Mountain Pass	1929	<.05	1131.7	0.08 ~ 0.11	1131.7	0.08 ~ 0.24	1131.7
Imperial Valley - SDG&E	1924	<.05	0	<.05	0	0.10	382.5
San Diego South	761	<.05	96	<.05	96	0.09	352
SDG&E non-CREZ	482.4	<.05	0	<.05	0	0.05 ~ 0.06	0
SCE Non-CREZ	190.8	<.05	0	<.05	0	0.11 ~ 0.15	0
Kramer	102.7	<.05	42.2	<.05	42.2	0.09	42.2
Tehachapi 230kV	92	<.05	0	<.05	0	0.08	0

Table 7: Shift factors by CREZ – Scenario B

Shift Factors and Dispatch by CREZ (Nipton-Lugo series capacitors in-service at Lugo)									
Limiting Facility		Lugo - Pisgah 230kV No. 2		N. Gila - IV 500kV		Lugo - Nipton 500kV		Lugo - Victorville 500kV	
Contingency		Normal		Red Bluff - Devers No. 1 & No. 2		Palo Verde - Colorado River 500 kV		Lugo - Nipton 500kV	
	PMAX	Shift Factors	PGEN	Shift Factors	PGEN	Shift Factors	PGEN	Shift Factors	PGEN
Pisgah	1650	0.31	340	0.06	136	0.06	272	<.05	136
San Bernardino - Lucerne	321	0.06	192.4	0.06	113.1	0.05	113.1	<.05	113.1
Riverside East (500kV)	3805	<.05	620	0.26	1945	<.05	620	<.05	620
Riverside East (161kV)	49.5	<.05	0	<.05	0	0.12	0	0.13	0
Mountain Pass	1929	<.05	1026.3	0.07 ~ 0.1	1026.3	0.14 ~ 0.61	1155.9	0.11 ~ 0.3	1155.9
Imperial - SDG&E	1924	<.05	0	<.05	0	0.12	977.5	0.10	510
San Diego South	761	<.05	96	<.05	96	0.11	454.4	0.09	352
SDG&E Non-CREZ	482.4	<.05	0	<.05	0	0.05 ~ 0.08	478	0.05 ~ 0.06	478
SCE Non-CREZ	190.8	<.05	0	<.05	0	<.05	0	0.11 ~ 0.15	0
Kramer	102.7	<.05	42.2	<.05	42.2	<.05	42.2	0.09	42.2
Tehachapi 230kV	92	<.05	0	<.05	0	<.05	0	0.08	0

Results – SDG&E Area

Table 8 lists the deliverability constraints identified in the SDG&E area study.

Table 8. Deliverability constraints

Contingency	Limiting Facility
Normal condition	Path 43 (North of SONGS) path rating

Generation withdrawal need

Between 600 and 1400 MW of generation in the SDG&E area are required to withdraw. The first number is based on the assumption that Encina units 4, 5 and GT (644 MW total) and Cabrillo II generation (188 MW) will not choose to be repowered. If these units choose to be repowered, their deliverability may need to be preserved, and more generation may be needed to withdraw from the Queue.

Table 9 lists the set of proposed generation projects for the deliverability constraint and Table 10 lists the shift factors on the constraint. The proposed generation dispatch by CREZ in the lower level of withdrawal case is also shown in Table 10.

Table 9. Generation Projects Contributing to the North of SONGS Deliverability Constraint

Generation Projects Contributing to the North of SONGS Deliverability Constraint			
Project Q#	POI	Pmax	CREZ
13	Olivehain-Bernardo-Rancho Santa Fe 69kV line	40	Non-CREZ
32	Boulevard Station 138kV Bus	201	San Diego South
103	Border Sub 69 kV Bus	27	Non-CREZ
124	Imperial Valley Substation 230kV bus	600	Imperial – SDG&E
137	Encina Substation 230kV bus	260	Non-CREZ
150	Border Substation	47.4	Non-CREZ
189	Encina 138kV Substation	260	Non-CREZ
337	Borrego Substation 69kV	25.75	Non-CREZ
429	Imperial Valley Substation	100	Imperial - SDG&E
442	Imperial Valley 230kV	125	Imperial - SDG&E
493	Sunrise Powerlink 500kV line	299	Imperial - SDG&E
510	Imperial Valley Substation 230kV bus	200	Imperial - SDG&E
561	Imperial Valley Sub 230kV bus	200	Imperial - SDG&E
565	Miguel-Mission 230kV	100	Non-CREZ
574	Otay Mesa Sub 230kV Bus	308	Non-CREZ
590	Imperial Valley Sub 230kV bus	150	Imperial - SDG&E
608	Imperial Valley Sub 230kV bus	250	Imperial - SDG&E
106A	Boulevard Sub 138kV Bus	160	San Diego South
159A	Imperial Valley-Miguel new 230/500kV Sub 230kV bus	400	San Diego South
Total MW		3753	

Table 10: Shift Factors by CREZ

Shift Factors and Dispatch by CREZ			
Limiting Facility		Path 43 (North of SONGS)	
Contingency		Normal	
	PMAX	Shift Factors	PGEN
Imperial - SDG&E	1924	0.26	868.6
San Diego South	761	0.33	275.5
Non-CREZ	1068.15	0.59 - 0.42	1037.2

Attachment – Power Flow Plots

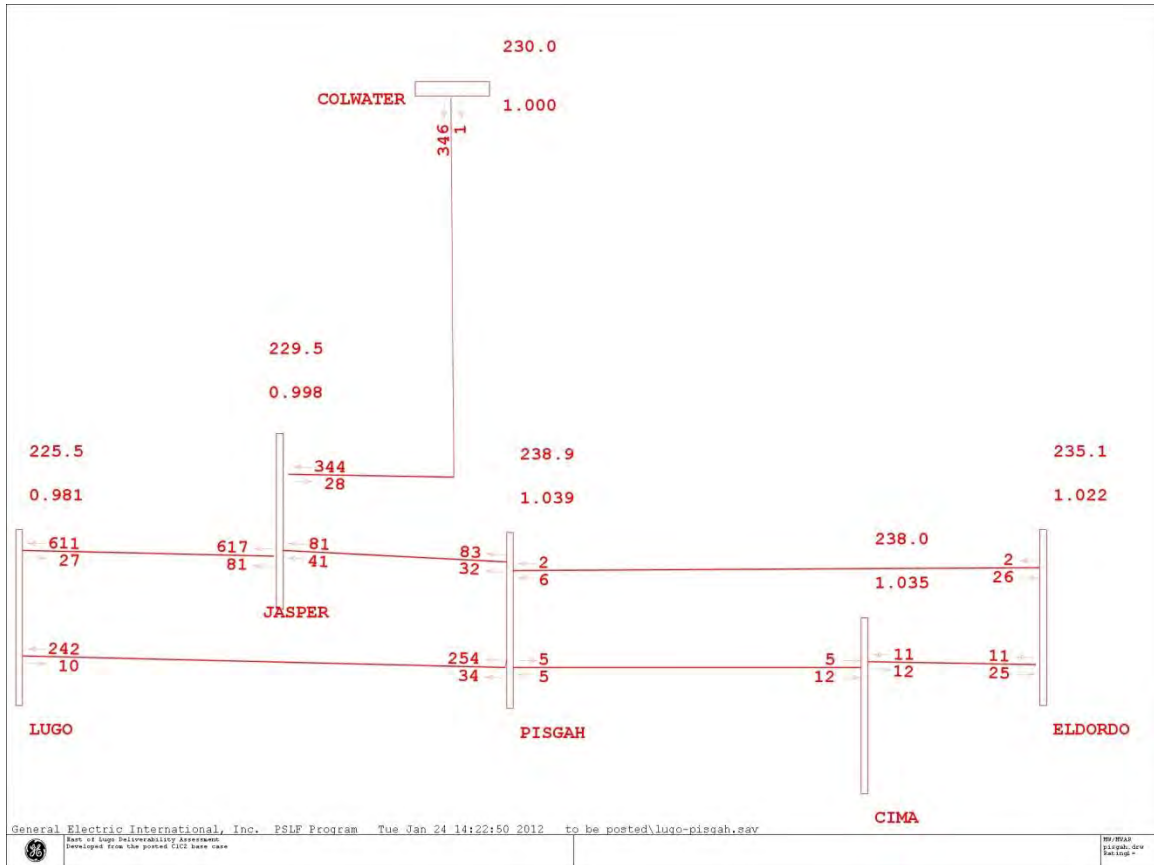

Figure 1: Lowest level of generation withdrawal under Scenario A: Lugo – Pisgah 230 kV is the limiting facility with all lines in service.

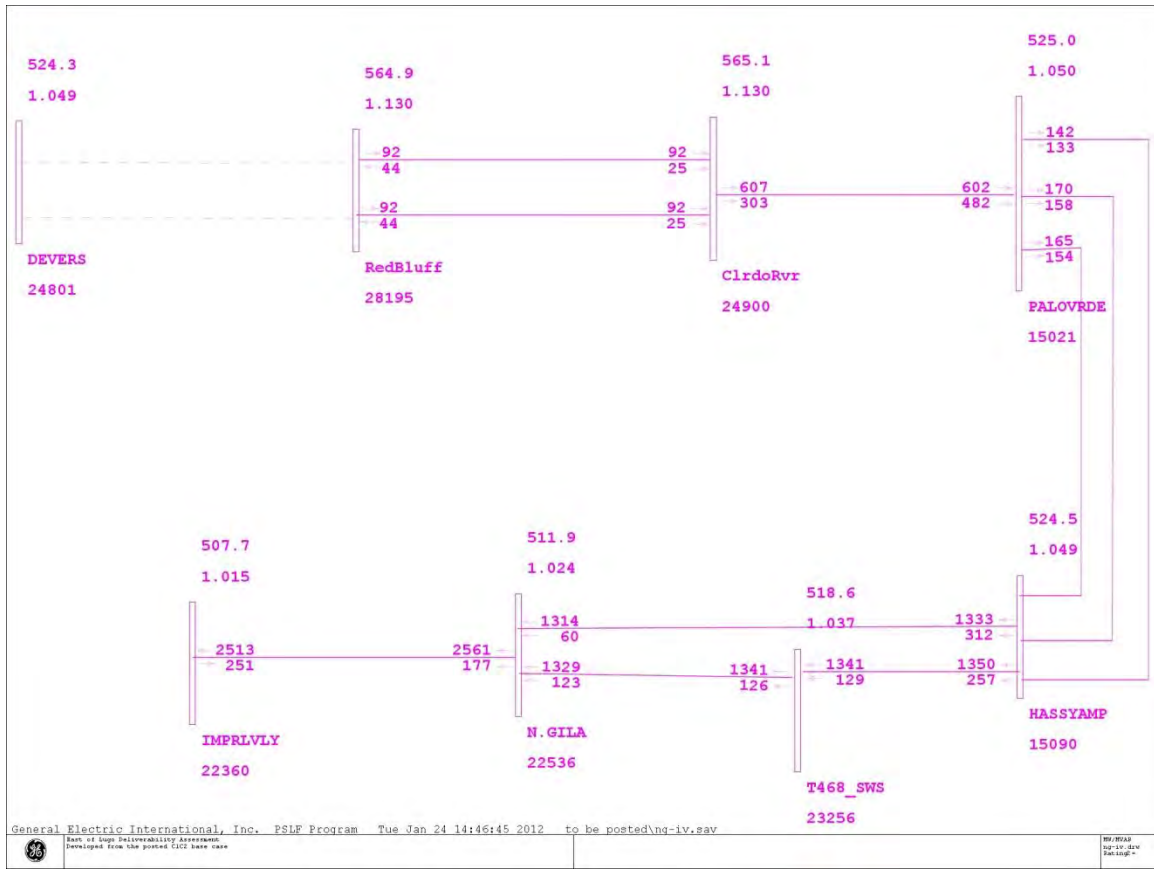

Figure 2: Lowest level of generation withdrawal under Scenario A: N. Gila – Imperial Valley 500 kV is a limiting facility with the outage of both Devers-Red Bluff 500 kV lines.

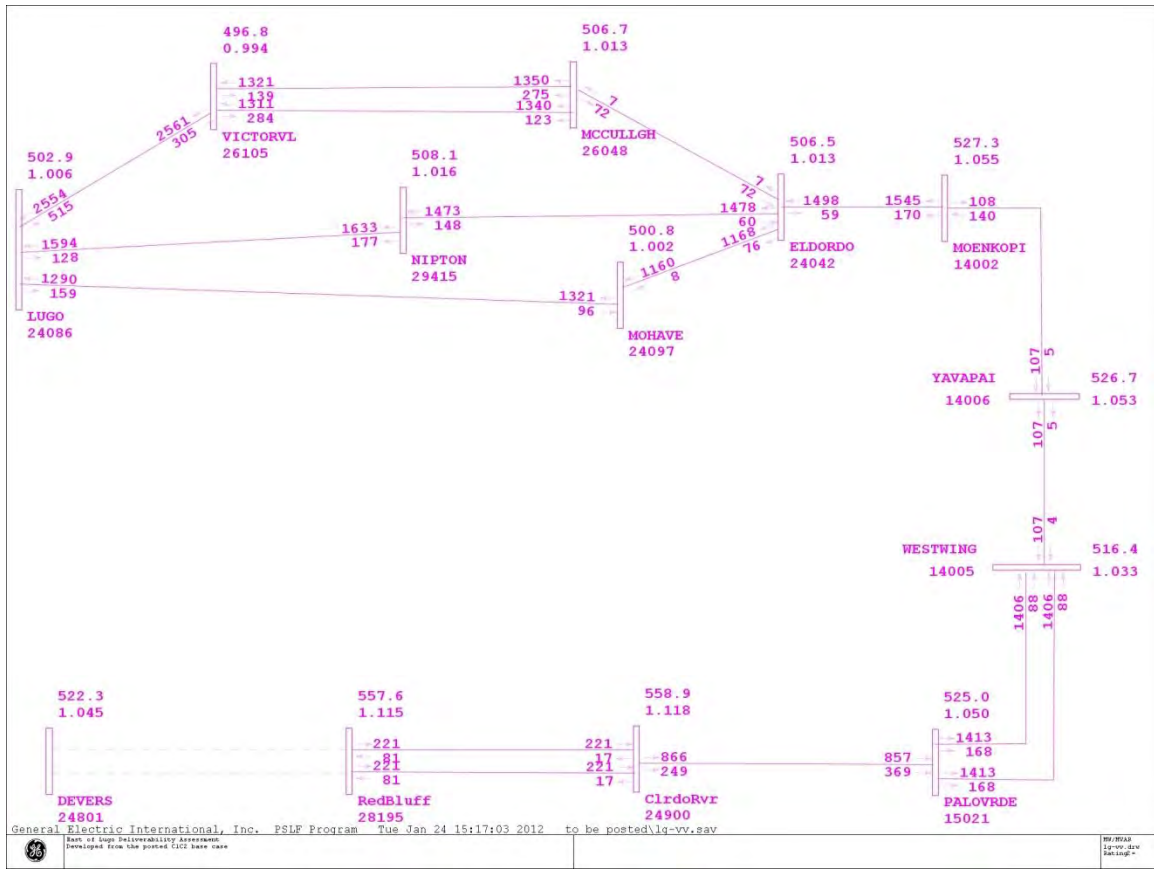

Figure 3: Lowest level of generation withdrawal under Scenario A: Lugo – Victorville 500 kV is a limiting facility with the outage of both Devers-Red Bluff 500 kV lines.

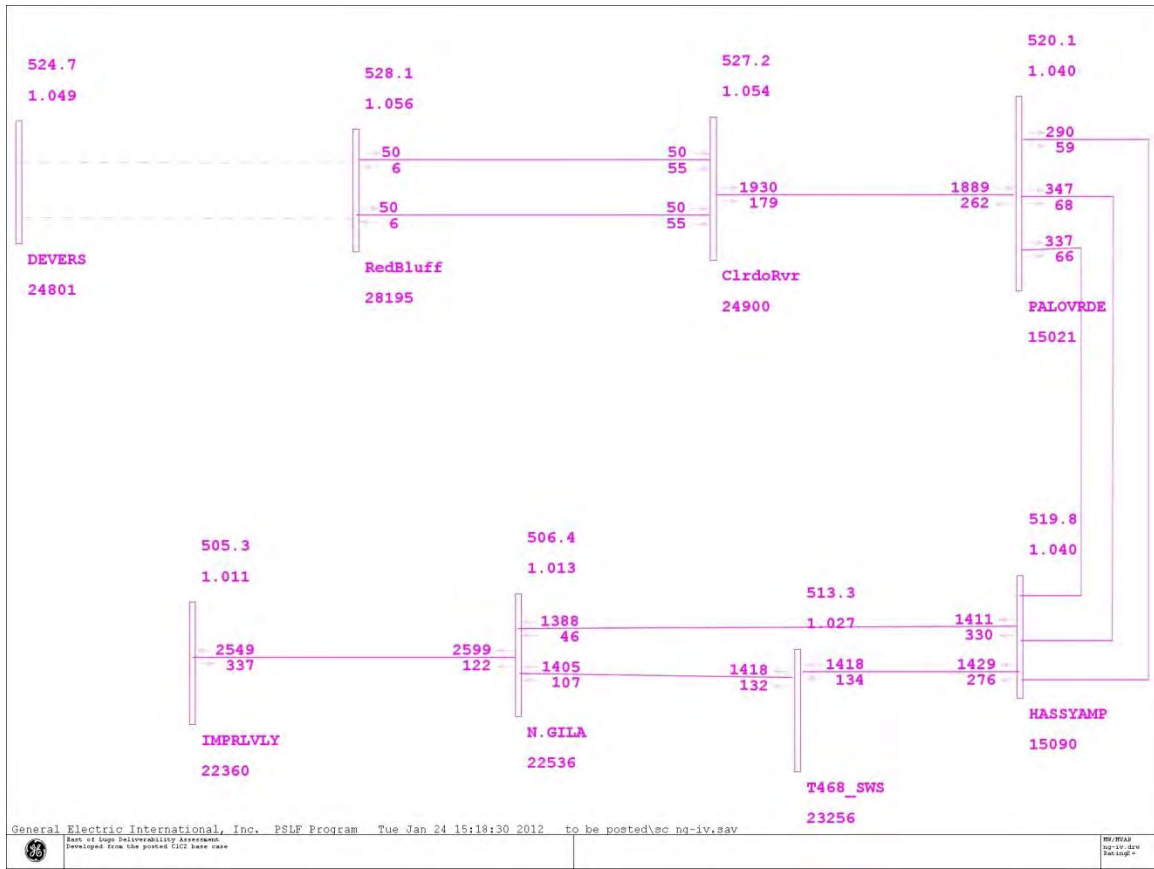

Figure 4: Lowest level of generation withdrawal under Scenario B: N. Gila – Imperail Valley 500 kV is a limiting facility with the outage of both Devers-Red Bluff 500 kV lines.

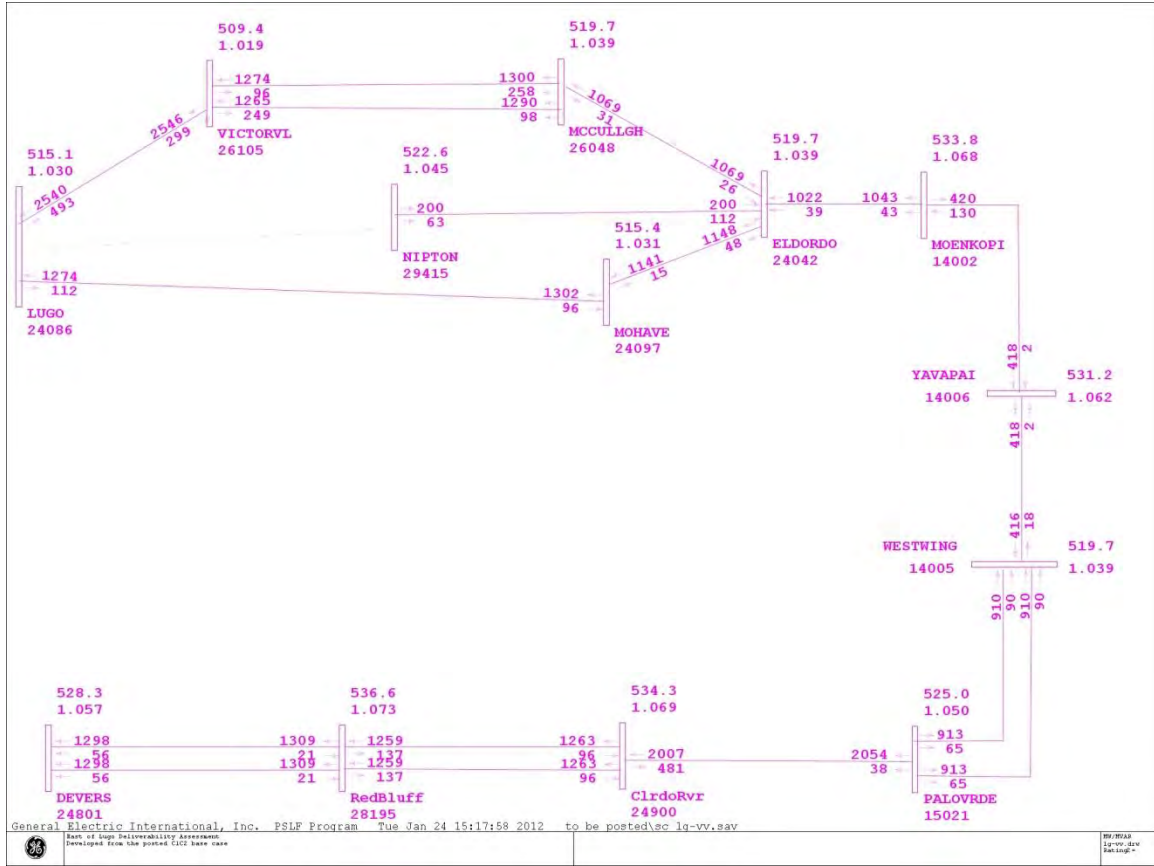

Figure 5: Lowest level of generation withdrawal under Scenario B: Lugo – Victorville 500 kV is a limiting facility with the outage of Lugo - Nipton 500 kV line.

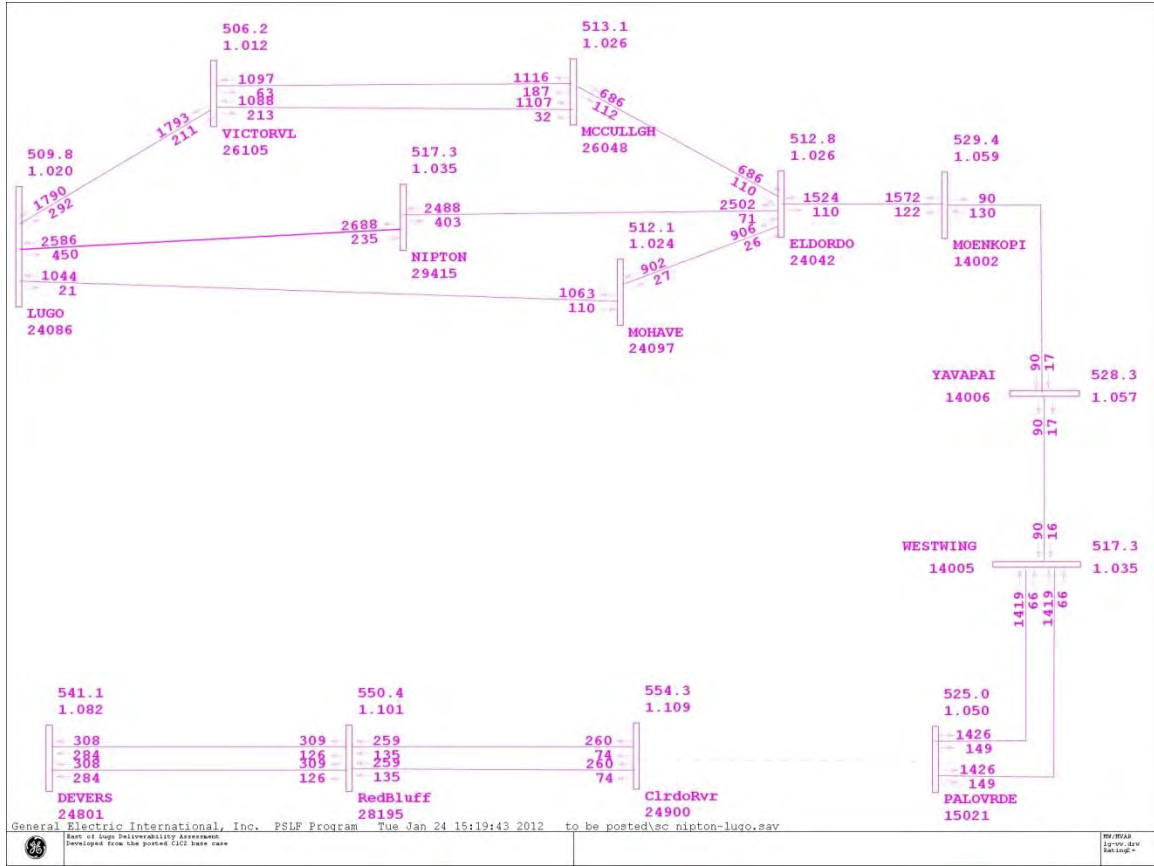

Figure 6: Lowest level of generation withdrawal under Scenario B: Lugo – Nipton 500 kV is a limiting facility with the outage of Palo Verde-Colorado River 500 kV line.

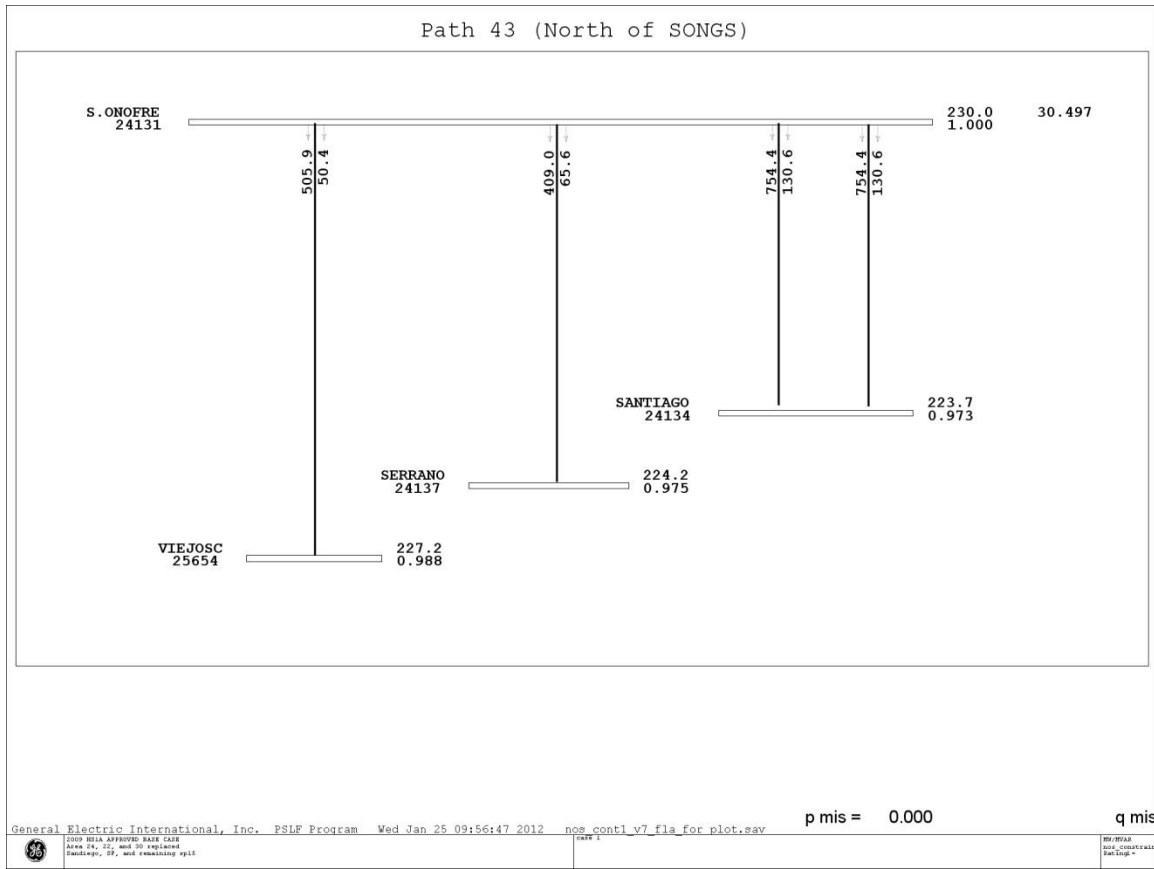

Figure 7. Lower level of generation withdrawal: NOS is the limiting constraint with all lines in service.