

## DOCKETED

<b>Docket Number:</b>	17-BSTD-01
<b>Project Title:</b>	2019 Building Energy Efficiency Standards PreRulemaking
<b>TN #:</b>	220506
<b>Document Title:</b>	Comments on Variable Exhaust Flow and Controls
<b>Description:</b>	Comments from Mike Wolf and Ken Kuntz
<b>Filer:</b>	Michael L. Wolf, P.E.
<b>Organization:</b>	Greenheck Group
<b>Submitter Role:</b>	Public
<b>Submission Date:</b>	8/2/2017 11:17:01 AM
<b>Docketed Date:</b>	8/2/2017

# The Greenheck Group

Greenheck • Airolite • Accurex • GlobeAire • Unison • Innovent • Valent • Precision Coils

August 1, 2017

Mr. Mark Alatorre, PE  
Building Standards Development  
California Energy Commission  
1516 Ninth Street, MS37  
Sacramento, CA 95814

## **RE: Docket Number 2017-BSTD-01; Variable Exhaust Flow Control (TN#-217909)**

---

These comments are submitted by the Greenheck Group in response to the Variable Exhaust Flow Control workshop presentation (TN#-217909) from June 6<sup>th</sup>, 2017 by R.J. Wichert.

### **Credentials:**

With over 31 years of experience with the Greenheck Group, a leading manufacturer of HVAC equipment, Mike Wolf has held positions in engineering, sales, marketing, software development and general management. As such, Mike has a solid foundation for understanding the impact regulations can have on a business and a market. Mike is active in the development of test standards and codes with industry trade associations including ASHRAE, AMCA, AHRI, UL, NFPA, ICC and others. Mike participated on the U.S. Department of Energy's Working Group responsible for developing recommendations on Commercial and Industrial Fan Energy Regulation. Mike is also a member of the U.S. Department of Energy's Appliance Standards and Rulemaking Federal Advisory Committee (ASRAC).

Ken Kuntz has over 11 years of experience designing and testing Laboratory Fume Exhaust Fans and Systems for Greenheck and over 25 years of design and manufacturing experience. Ken is an active member on ASHRAE TC 9.10, Laboratory Systems.

The Greenheck Group is comprised of a number of brands including Greenheck, Unison Comfort Technologies, Innovent, Valent, Precision Coils, Accurex, and Airolite. Headquartered in Schofield, WI, Greenheck has offices and manufacturing facilities in California, Wisconsin, Kentucky, Tennessee, North Carolina, Mexico, and India. In the coming year we will be expanding our manufacturing footprint to include Oklahoma. Greenheck employs nearly 4,000 people worldwide, including over 3,500 in the United States. With over 70 years of family ownership, Greenheck is a worldwide leader in the manufacture of air-movement, conditioning and control equipment, systems and services. Greenheck's extensive product offering includes commercial fans and industrial blowers, laboratory exhaust systems, dedicated outdoor air systems, energy recovery ventilators, air handling equipment, make-up air equipment and kitchen ventilation systems. Related products include air-control dampers, fire and smoke control dampers, heating and cooling coils as well as architectural and mechanical louvers.



Greenheck equipment is used in all types of commercial, institutional, and industrial buildings and applications ranging from comfort ventilation to industrial processes.

### **Industry Associations**

Greenheck engineers are actively involved with many government and industry organizations working to establish performance standards and application guidance related to HVAC systems and products. Examples include:

- United States Department of Energy (DOE)
- International Standards Organization (ISO)
- American Society of Heating, Refrigerating, and Air-Conditioning Engineers (ASHRAE)
- Air Movement & Control Association (AMCA)
- Air-Conditioning, Heating, & Refrigeration Institute (AHRI)
- International Code Council (ICC)

Greenheck's involvement with the aforementioned groups is largely focused on development of standards, regulations and programs that result in energy efficient HVAC systems as well as practical selection and application of energy efficient products manufactured for these systems. Greenheck is continuously working with these organizations and other industry members to provide constructive, consistent and substantial insight regarding industry standards and regulations.

### **Comments**

Specific recommendations and commentary regarding code changes are provided below in red.

#### **Slide 24 - Proposed Code Language**

**SECTION 140.9 – PRESCRIPTIVE REQUIREMENTS FOR COVERED PROCESSES**  
Prescriptive Requirements for Laboratory and Process Facility exhaust systems.

1. Fan System Power Consumption. All newly installed fan systems for a laboratory or process facility exhaust system greater than 10,000 CFM, shall meet the discharge requirements in ANSI Z9.5-2012 and at least one of the requirements of Items 140.9(c)1A, B, or C. Exhaust fan system power demand equals the sum of the power demand of all fans in the exhaust system that are required to operate at **normal occupied** design conditions in order to exhaust air from the conditioned space to the outdoors. Exhaust air does not include bypass air or entrained air, but does include all exhaust air from fume hoods, hazardous exhaust flows, or other mani-folded exhaust streams.
  - A. The allowable exhaust fan system power demand shall not exceed ~~0.45~~**0.65** (\*Please see commentary at the end of the Comment section) watts per cfm of exhaust air. **The exhaust fan system, including fan, nozzle, stack and wind band shall be licensed to bear the AMCA ratings seal for air performance (AMCA 210) or AMCA ratings seal for induced flow fan high plume dilution blowers (AMCA 260) or**  
**(Commentary: AMCA 3<sup>rd</sup> party certification verification is important to ensure performance compliance. A non-AMCA certified system may not provide the energy efficiency required and may cause system performance issues.**

Additionally, if only an AMCA certified fan is installed but field fabricated nozzles, stacks or other accessories which have not been tested with the fan are added, the system may not provide the required performance. A fully AMCA certified exhaust fan system will preclude the need for additional acceptance testing).

- B. The motor speed shall vary based on measuring wind speed **and direction** taken from a calibrated local station. Wind speed controls must reduce the exhaust exit velocity ~~by no less than 50%~~ to a **minimum safe level based upon chemical concentration amounts at critical receptors** when the wind speed and appropriate **direction** falls below a threshold. Exit velocity shall not fall below 2000 fpm to ensure condensing vapors do not fall back into the fan system. Wind analysis to be determined by a certified wind engineer, while maintaining a **minimum dilution of 3000 :1**; or

(Commentary: Wind analysis needs to include not only wind speed, but direction. Critical receptors (air intakes, adjacent buildings, etc.) are dependent upon the direction the wind is blowing. Additionally, even during high wind conditions in a favorable direction, the exhaust velocity can be reduced since there are no critical receptors on the downwind direction. Thus energy savings can be realized.)

(Commentary: Knowledge of the chemicals being used and emitted at a facility is also important. Safe exposure limits are unique to each chemical and single common dispersion analysis or dilution ratio (i.e. 3000:1) would need to be done on a worst case basis, thus rendering the potential energy savings to a minimal level when those chemicals are not being used.)

- C. The motor speed shall vary based on measuring contaminants in the exhaust plenum from a calibrated contaminant sensor. Contaminant concentration controls must maintain a **minimum dilution** in the exhaust plenum of 750 :1 when the contaminant concentration falls below 0.5 ppm and a **minimum dilution** in the exhaust plenum of 3000:1 when the contaminant concentration exceeds 0.5 ppm.

(Commentary: Depending on the chemicals in the system and the hazard level of the chemicals and subsequent combinations a single dilution ratio ( i.e. 750:1 or 3000:1) will be difficult to specify. The Environmental Health and Safety officer for a given facility will need to evaluate and determine the appropriate dilution ratios.)

## 2. Exhaust Control Devices

- A. For each system with wind-speed/**direction** controlled exhaust, a wind speed sensor shall be installed on the roof next to the exhaust plenums(**typically on the corner of the building**) that meets the criteria of Section 140.9(c)1;

(Commentary: Interference on wind speed or direction from adjacent equipment or buildings is important. Placement of the wind anemometer next to a system that is placed in the middle of the roof may not provide adequate information. Typically the anemometer is placed at the edge of a building)

- B. Wind speed/**direction** sensors shall be certified by the manufacturer to be accurate within plus or minus 60 fpm( **and XX.X degrees**) when measured at sea level and 25°C, factory calibrated, and certified by the manufacturer to require calibration no more frequently than once every 5 years. Upon detection of sensor failure, the

- system shall provide a signal which resets to exhaust the minimum quantity of air to achieve the criteria of Section 140.9(c)1B at the ASHRAE 1% design wind speed;
- C. For each system with contaminant concentration controlled exhaust, a contaminant sensor shall be installed within each exhaust plenum that meets the criteria of Section 140.9(c)1;
  - D. Contaminant concentration sensors shall be Photo Ionization Detectors (PID) certified by the manufacturer to be accurate within plus or minus 5% when measured at sea level and 25°C, factory calibrated, and certified by the manufacturer to require calibration no more frequently than once every 6 months. Upon detection of sensor failure, the system shall provide a signal, which resets to exhaust the minimum quantity of air to achieve the criteria of Section 140.9(c)1C at a contaminant concentration above 0.5 ppm.

\*Commentary: It is not clear to the reader where the proposed value limit of 0.45 watts/cfm came from. After performing multiple fan selections for common lab exhaust design points of 10,000 cfm and 20,000 cfm, the 0.45 watts/cfm does not appear to be achievable even with the most efficient fan for a given operating point including fan only without nozzles.

Table 1 below shows the performance and energy usage at the two design points for a variety of commonly used lab exhaust fans (see chart 1 for renderings of each fan type analyzed). Each fan listed is the most energy efficient selection for that style fan meeting the design point and a minimum of 3000 fpm exit velocity. Selections for Table 1 were made using fan selection software. Each fan type had multiple selection options.

<b>Table 1: Fan Energy Consumption</b>					
<b>Example 1</b>					
<b>Design Pt. - 10000 cfm</b>					
<b>3 in. w.g.</b>					
<b>Fan Type</b>	<b>Size</b>	<b>BHP</b>	<b>plume rise</b>	<b>exit vel</b>	<b>watts/cfm</b>
Centrifugal High Plume	24	8.05	23.5	3422	0.600
Centrifugal Induced Flow	33	8.11	17.7	3165	0.605
Mixed Flow High Plume	27	8.43	21.9	3185	0.629
Mixed Flow Induced Flow	27	9.10	15.2	3125	0.679
Centrifugal Air Foil	24	8.45	23.9	3227	0.630
<b>Example 2</b>					
<b>Design Pt. - 20000 cfm</b>					
<b>3 in. w.g.</b>					
<b>Fan Type</b>	<b>Size</b>	<b>BHP</b>	<b>plume rise</b>	<b>exit vel</b>	<b>watts/cfm</b>
Centrifugal High Plume	36	14.88	28.48	3090	0.555
Centrifugal Induced Flow	36	15.37	25.73	3107	0.573
Mixed Flow High Plume	36	17.43	29.73	3170	0.650
Mixed Flow Induced Flow	36	18.08	18.4	3317	0.674
Centrifugal Air Foil	33	15.97	33.14	3360	0.595

Table 2 shows a sample of possible selections for the centrifugal high plume fan with an airfoil wheel. All selections meet the 10,000 cfm at 3 in w.g. and a minimum of 3000 fpm exit velocity. The cost ratio column allows the user to compare relative costs between selections. The lower the ratio, the lower the initial fan cost. Often times higher plume rises are needed to meet codes or individual building needs. This will typically consume more energy. Regardless of the fan size selected or plume rise needed for this design point an energy level of 0.45 watts/cfm cannot be met.

<b>Table 2: Sample selections at 10,000 cfm @ 3 in. w.g.</b>					
<b>Fan Type</b>	<b>Size</b>	<b>cost ratio</b>	<b>BHP</b>	<b>Plume Rise</b>	<b>watts/cfm</b>
Centrifugal High Plume	24	1.05	8.05	23.5	0.600
Centrifugal High Plume	30	1.29	8.46	22.5	0.631
Centrifugal High Plume	33	1.84	8.62	23.5	0.643
Centrifugal High Plume	36	1.56	8.91	22.5	0.664
Centrifugal High Plume	40	1.76	9.14	21.4	0.682
Centrifugal High Plume	27	1.16	9.22	27.5	0.688
Centrifugal High Plume	30	1.28	9.51	26.5	0.709
Centrifugal High Plume	33	1.72	9.78	28.5	0.729
Centrifugal High Plume	27	1.19	10.78	30.5	0.804
Centrifugal High Plume	22	1.00	12.85	33.5	0.958
Centrifugal High Plume	22	1.02	16.32	37.5	1.217

Based upon these results shown in Tables 1 and 2 above, we recommend a level of 0.65 watts/cfm for a dedicated lab exhaust fan system. Using the 0.65 watts/cfm requirement for the examples in Tables 1 and 2 above will eliminate inefficient selections without the need for additional monitoring equipment.

**Chart 1: Typical Lab Exhaust Fan Types**

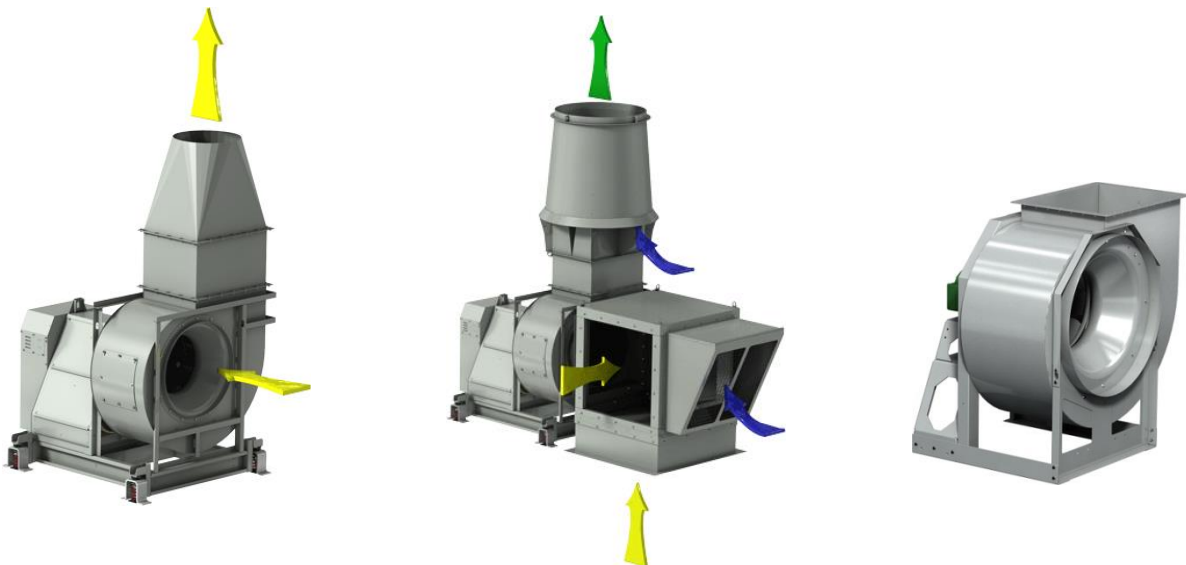

Centrifugal High Plume



Mixed Flow High Plume

Centrifugal Induced Flow



Mixed Flow Induced Flow

Centrifugal Air Foil

In closing, Greenheck very much supports efforts to reduce energy consumption through practical and timely initiatives. This includes coordination and harmonization between appliance standards, energy codes and related compliance requirements.

Respectfully Submitted,

*Michael L. Wolf*

Michael L. Wolf, P.E.  
Director, Regulatory Business Development  
[www.greenheck.com](http://www.greenheck.com)

*Ken Kuntz*

Ken Kuntz  
Engineering Manager, Lab & Fume Exhaust Systems