

## DOCKETED

<b>Docket Number:</b>	16-TRAN-01
<b>Project Title:</b>	SB 350 Transportation Electrification (Publicly Owned Utilities)
<b>TN #:</b>	214654
<b>Document Title:</b>	Presentation - Vehicle-Grid Integration Communications Standards Workshop - Volkswagen Group Statement
<b>Description:</b>	7/12/16
<b>Filer:</b>	Tami Haas
<b>Organization:</b>	Volkswagen
<b>Submitter Role:</b>	Public
<b>Submission Date:</b>	12/7/2016 8:36:04 AM
<b>Docketed Date:</b>	12/7/2016

# VOLKSWAGEN

AKTIENGESELLSCHAFT



## **Vehicle-Grid Integration Communications Standards Workshop - Volkswagen Group Statement -**

Sacramento, 07.12.2016

# The Volkswagen Group and it's Brands

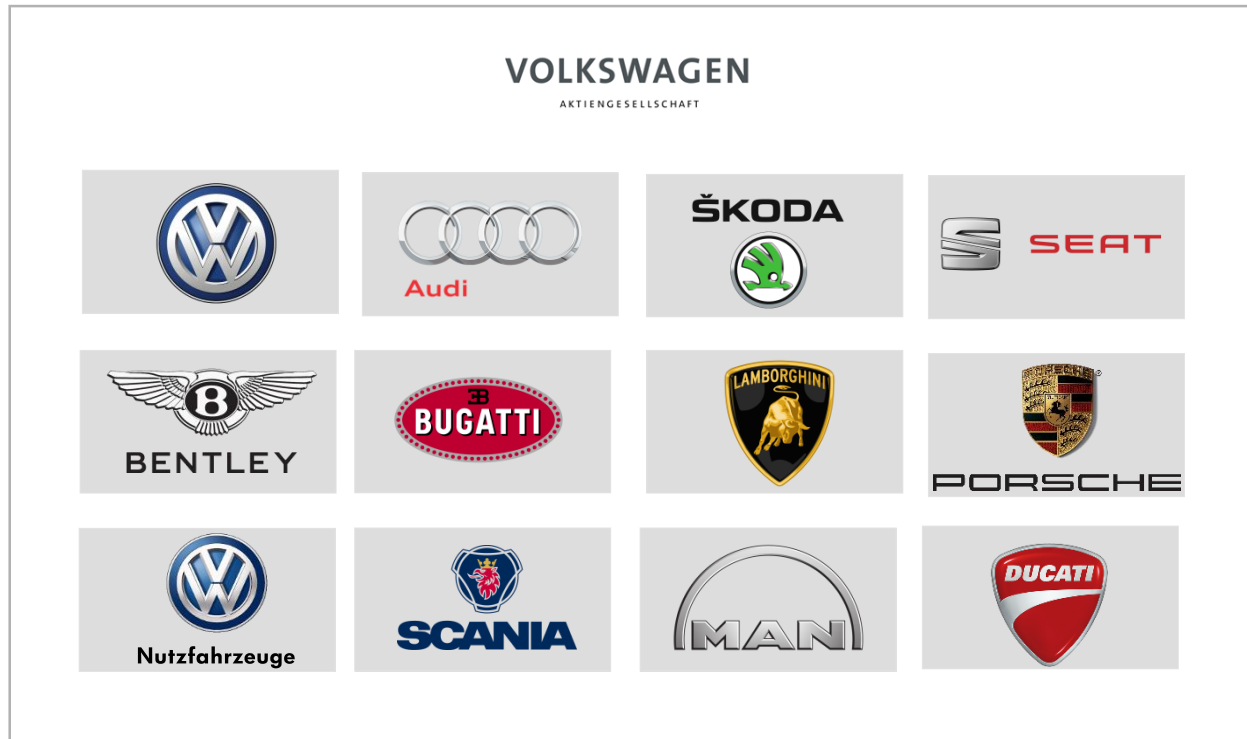

# ELECTRIFICATION INITIATIVE AS ONE STRATEGIC PILLAR WITHIN VOLKSWAGEN GROUP'S STRATEGY <<TOGETHER 2025>><sup>1)</sup>



- ◆ Goal: to position Volkswagen Group as driving force behind the expansion of electro-mobility; e-car to become a new hallmark of the Group
- ◆ >30 new pure-electric vehicles by 2025
- ◆ Annual unit sales of 2 to 3 million e-cars by 2025, equivalent to 20-25 percent of total sale



## Electric Vehicle Grid Integration - Official statement from the Volkswagen Group

- ▶ The Volkswagen Group (as part of ccs coalition) fully supports the use of ISO 15118 for AC and DC charging.
- ▶ The ISO 15118 forms the basis for future load management functions (price based).
- ▶ Vehicles are gradually being fitted with ISO 15118.
- ▶ We reject an expansion of PWM-Signals.
- ▶ We see a clear advantage by using ISO/IEC 15118 compared to SEP 2.0

# To consider all customer & device needs, Home Energy Management becomes very complex...

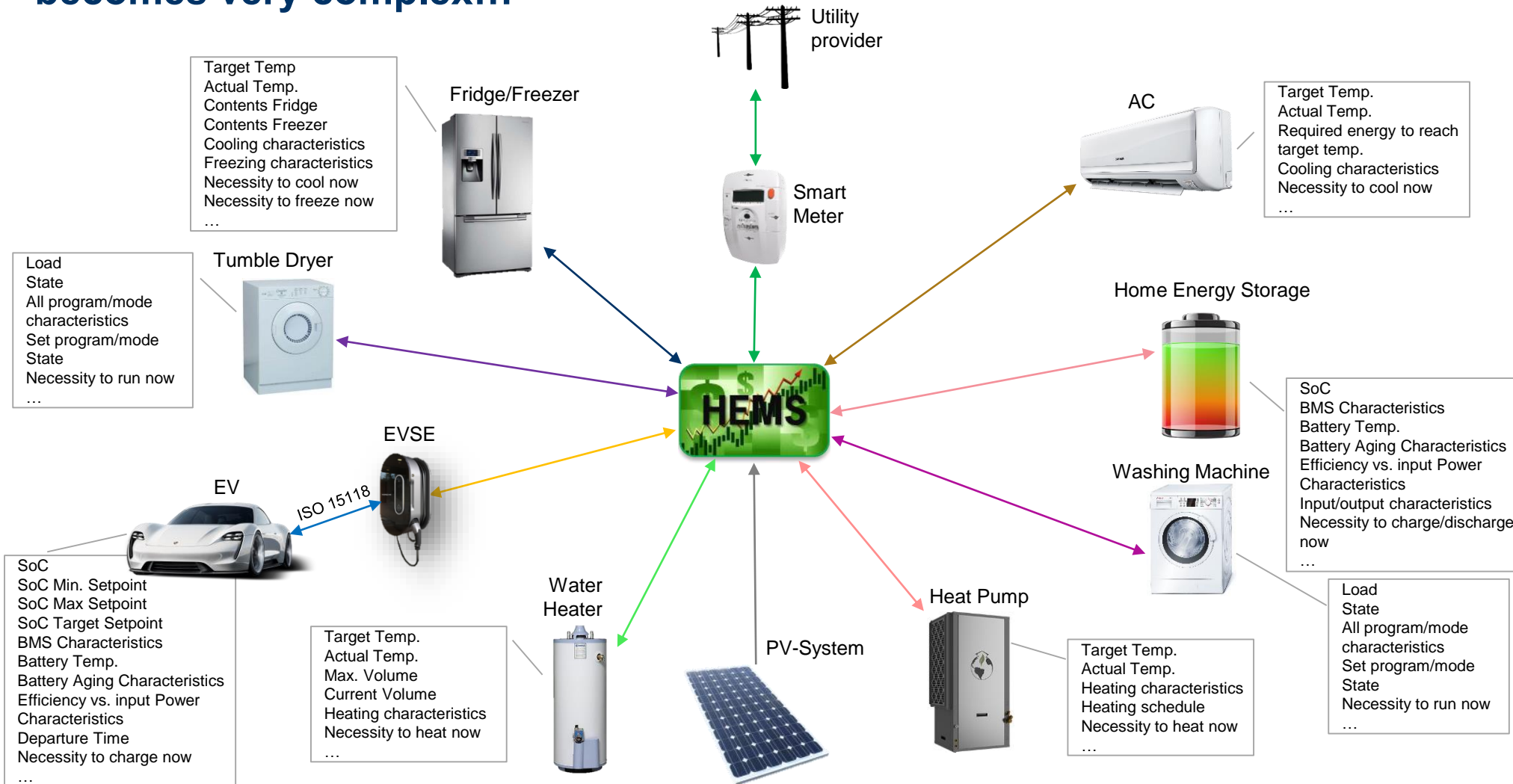

...or we could just use price based incentives!

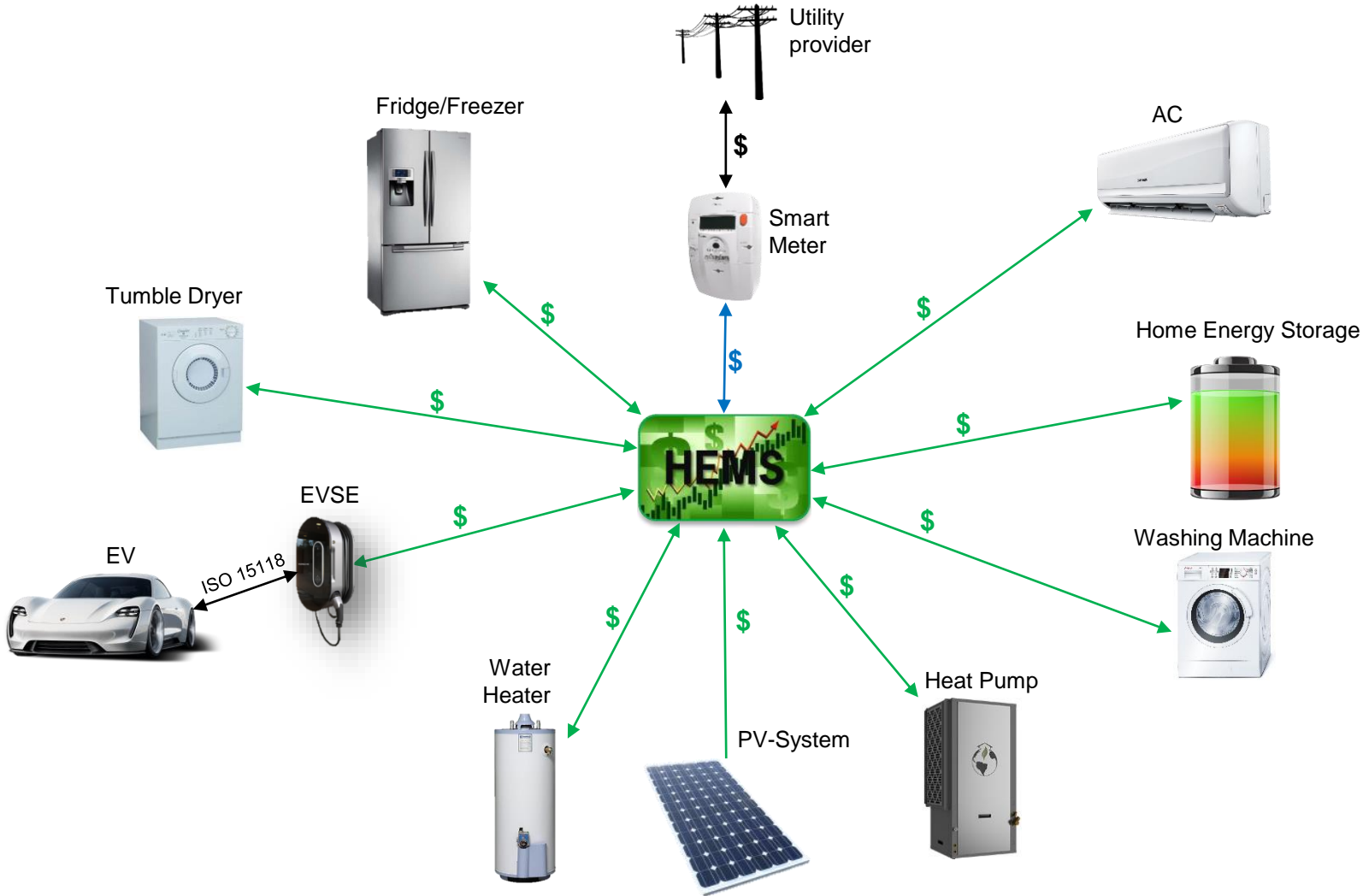

# ISO15118's price based incentives fully supports Vehicle Integration into Smart Grids

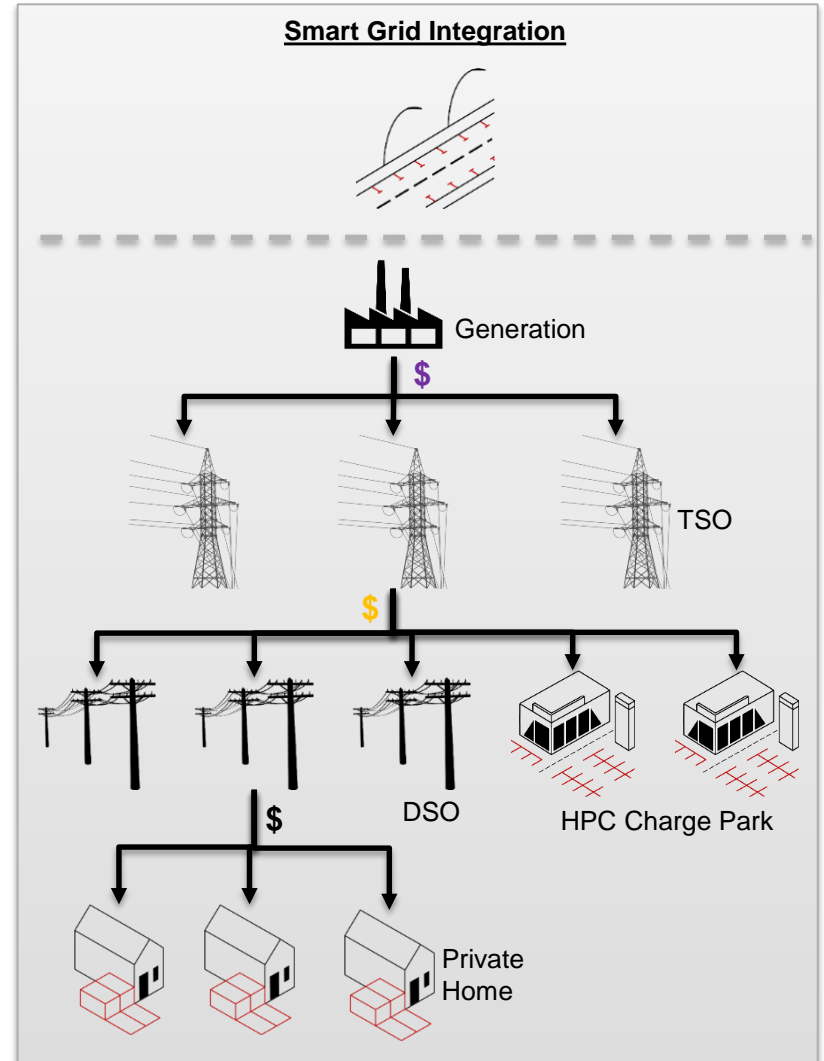
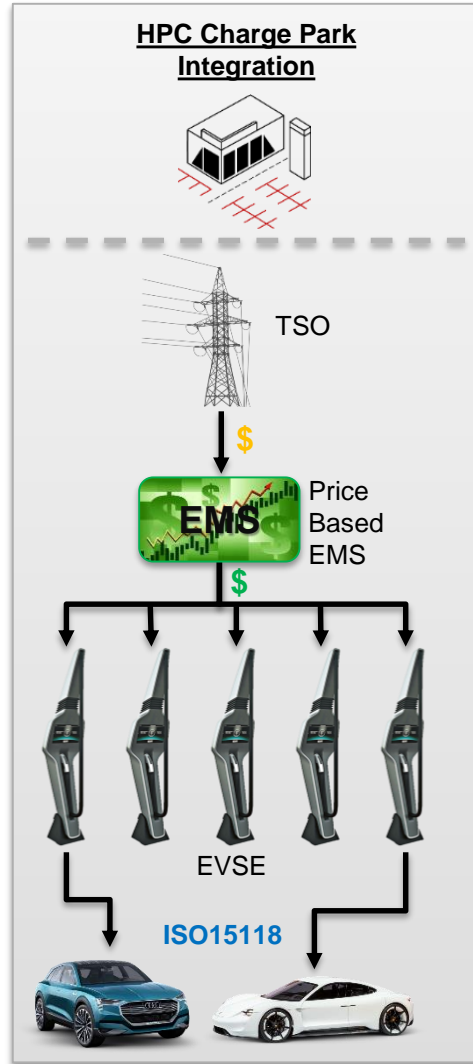
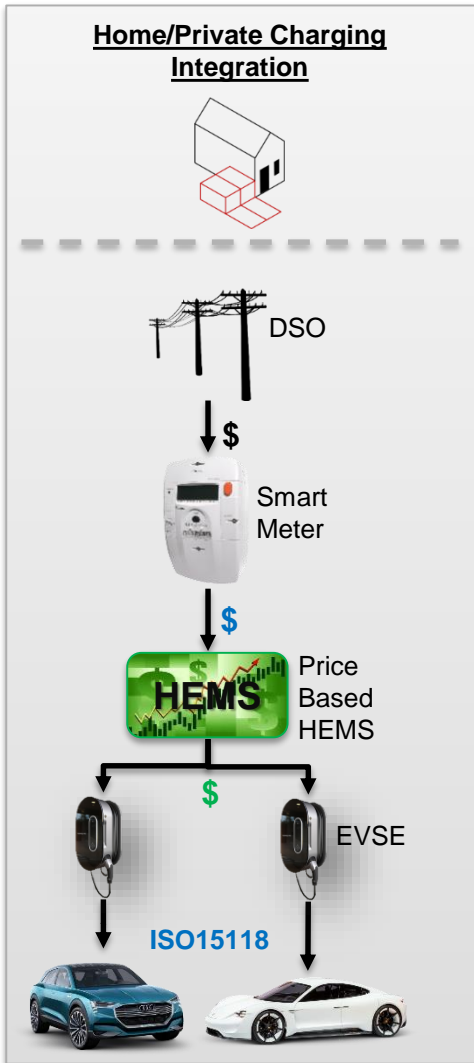



## 1) Disclaimer Volkswagen Group Strategy <<Together 2025>>

- ▶ The following presentations contain forward-looking statements and information on the business development of the Volkswagen Group. These statements may be spoken or written and can be recognized by terms such as “expects”, “anticipates”, “intends”, “plans”, “believes”, “seeks”, “estimates”, “will” or words with similar meaning. These statements are based on assumptions relating to the development of the economies of individual countries, and in particular of the automotive industry, which we have made on the basis of the information available to us and which we consider to be realistic at the time of going to press. The estimates given involve a degree of risk, and the actual developments may differ from those forecast.
- ▶ Consequently, any unexpected fall in demand or economic stagnation in our key sales markets, such as in Western Europe (and especially Germany) or in the USA, Brazil or China, will have a corresponding impact on the development of our business. The same applies in the event of a significant shift in current exchange rates relative to the US dollar, sterling, yen, Brazilian real, Chinese renminbi and Czech koruna.
- ▶ If any of these or other risks occur, or if the assumptions underlying any of these statements prove incorrect, the actual results may significantly differ from those expressed or implied by such statements.
- ▶ We do not update forward-looking statements retrospectively. Such statements are valid on the date of publication and can be superseded.
- ▶ This information does not constitute an offer to exchange or sell or an offer to exchange or buy any securities.