

DOCKETED

Docket Number:	07-AFC-06C
Project Title:	Carlsbad Energy Center - Compliance
TN #:	203523
Document Title:	PSA Workshop Introduction, dated January 12, 2015 (PowerPoint)
Description:	PowerPoint Presentation
Filer:	Alicia Campos
Organization:	California Energy Commission
Submitter Role:	Commission Staff
Submission Date:	1/15/2015 3:36:00 PM
Docketed Date:	1/15/2015



CALIFORNIA ENERGY COMMISSION

PSA Workshop Introduction
Jon Hilliard / Mike Monasmith
Project Managers

Carlsbad Energy Center Project
Amendment

January 12, 2015





Today's Workshop

- ❖ **Approximately 7 Hours**
- ❖ **Breaks (15 Minutes)**
- ❖ **Dinner (1.5 Hours)**
- ❖ **Topics**
 - Public Health
 - Waste and Hazardous Materials
 - Worker Safety and Fire Protection
 - Visual Impacts
 - Noise and Vibration
 - Air Quality
- ❖ **Conclude around 9 PM**



Workshop Participation

Monday, January 12, 2015

Beginning at 1:00 PM, recess from 5:00 PM to 6:30 PM

WebEx telephone/call-in toll-free number: 1-866-469-3239

WebEx meeting number: 925 892 950

WebEx meeting password: Meeting@1399

Tuesday, January 13, 2015

Beginning at 9:30 AM

WebEx telephone/call-in toll-free number: 1-866-469-3239

WebEx meeting number: 924 986 367

WebEx meeting password: Meeting@930

Wednesday, January 14, 2014,
starting at 2:30 PM

California Energy Commission
1516 Ninth Street ; Hearing Room B, 1st Floor,
Sacramento, CA 95814

WebEx telephone/call-in toll-free number: 1-866-469-3239

WebEx meeting number: 927 881 481

WebEx meeting password: Meeting@1430.



Energy Commission Public Advisor

Alana Mathews

(916) 654-4489 or

toll free in California at (800) 822-6228, or
by email at

publicadvisor@energy.ca.gov or

By “Blue Card”

STATE OF CALIFORNIA
CALIFORNIA ENERGY COMMISSION
www.energy.ca.gov (PLEASE HAND TO THE PUBLIC ADVISER)

DATE: _____

(optional): Favor _____ Oppose _____ Neutral _____

Do you require translation?

NAME/TITLE: _____ (Please Print)

REPRESENTING: _____ (Name of Organization or Group)

REMARKS, (IF ANY): _____

ITEM #: _____



Project Web Information

- ❖ A copy of the PSA is available on the project web site at:

<http://docketpublic.energy.ca.gov/Public Documents/12-AFC-03/TN203457>

- ❖ Carlsbad Energy Center Web Page at:

<http://www.energy.ca.gov/sitingcases/carlsbad/>

- ❖ General Siting Case Information at:

<http://www.energy.ca.gov/sitingcases/alphabetical.html>



CALIFORNIA ENERGY COMMISSION

North Coast
Service
Center

Coastal Rail
Trail
alignment





CALIFORNIA ENERGY COMMISSION



Legend

- Project Area of Analysis
- Encina Power Station Site
- Licensed CECP
- Poseidon Desalination Site
- Tank Removed As Part of the Development of the Poseidon Desalination Plant
- Tanks to be Removed Under the Proposed Amendment
- Tanks to be Removed as a Part of the Licensed CECP
- Railway ROW
- Railroad

Phase I



Phase II -- Construction

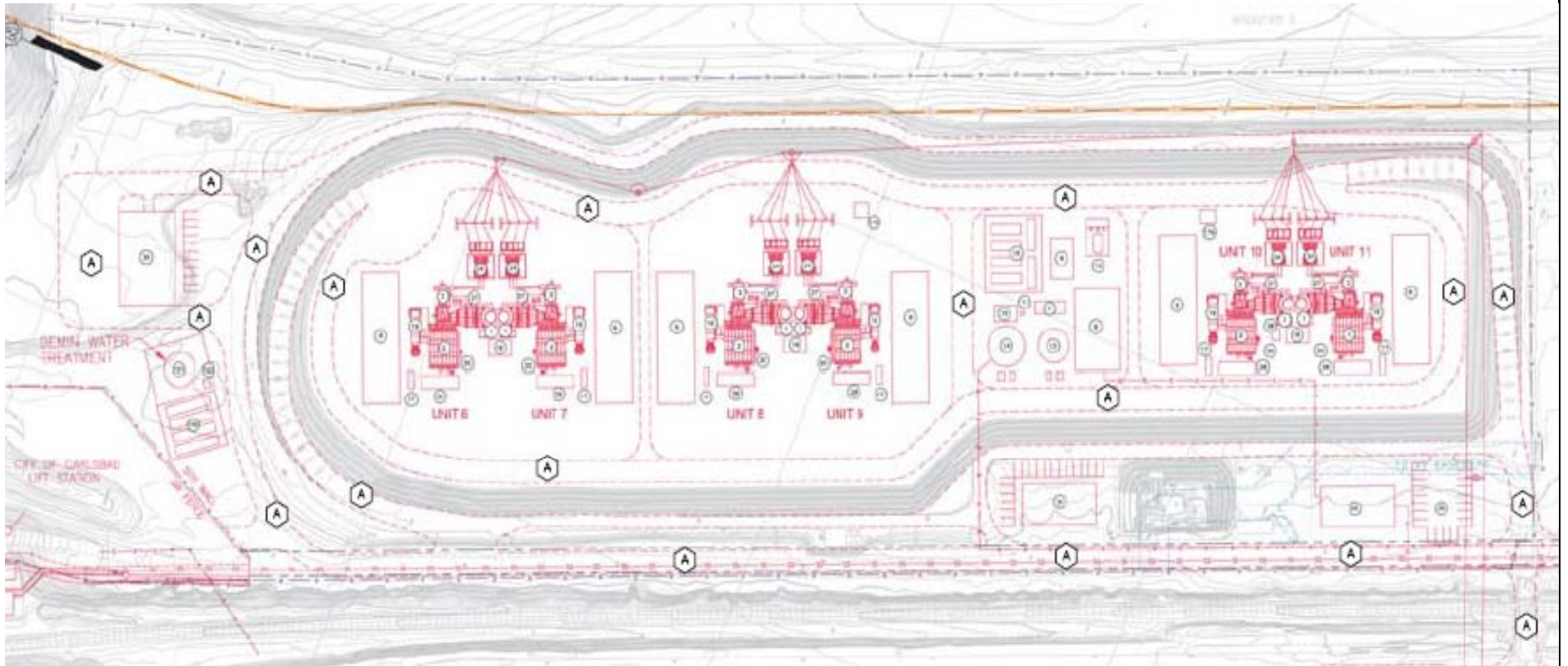

Phase IV -- Demolition

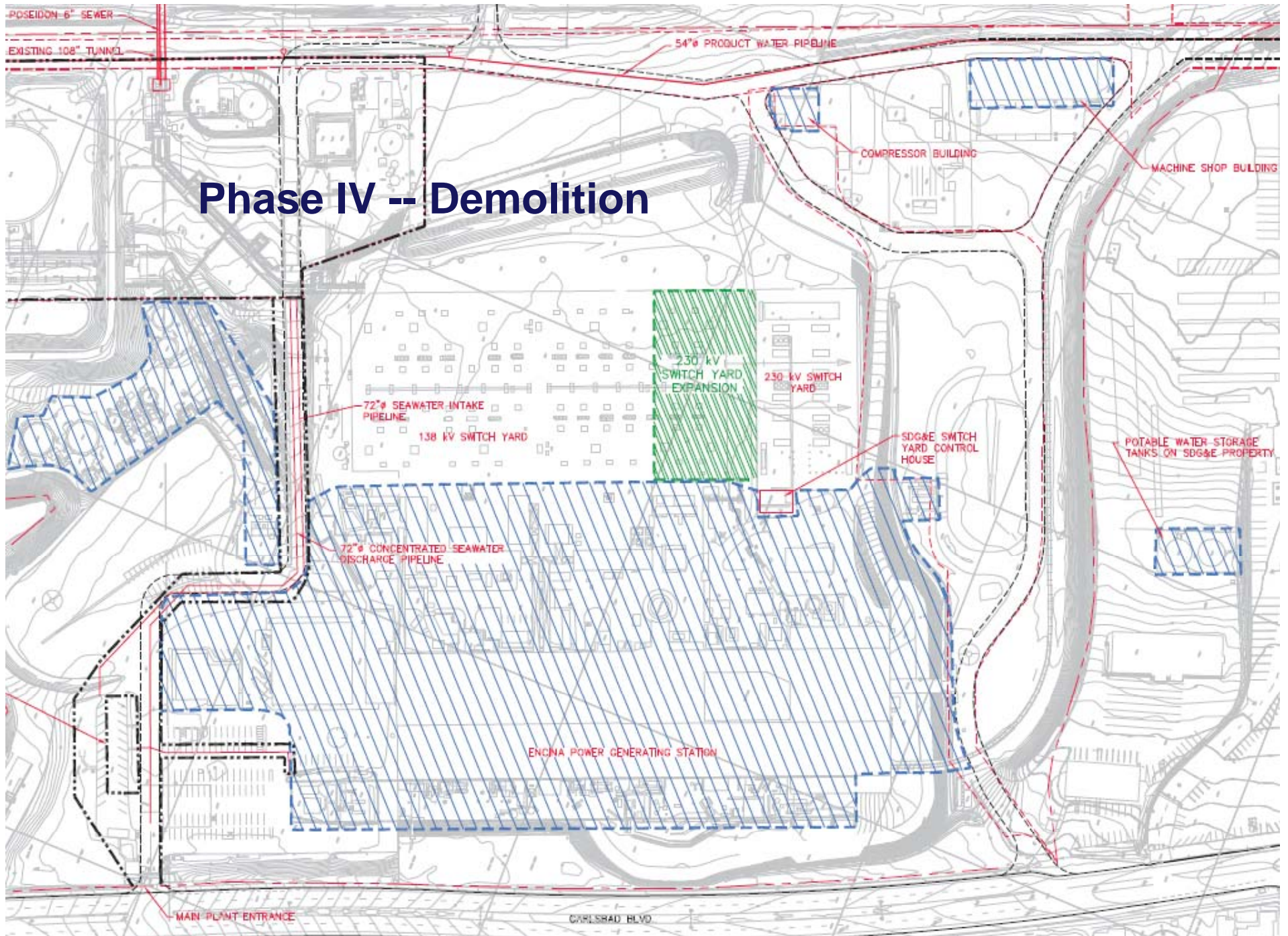



CALIFORNIA ENERGY COMMISSION

SCHEDULE

ACTIVITY	DATE
Petition to Remove Filed	4-29-14
Petition to Amend Filed	5-02-14
Site Visit and Informational Hearing	8-07-14
Data Response and Issue Resolution Workshop	9-24-14 – 9-25-14
Discovery (Data Requests) Cut Off (requests must be filed by this date or Committee permission for later filing obtained)	10-29-14
Parties file Status Reports	10-31-14
Committee Status Conference	11-3-14
San Diego Air Pollution Control District (SDAPCD) files Preliminary Determination of Compliance (PDOC)	11-10-14 or earlier
California Coastal Commission files comments	Tbd
Parties file Status Reports	12-1-14
Committee Status Conference	12-3-14
Staff publishes Preliminary Staff Assessment (PSA)	12-15-14



CALIFORNIA ENERGY COMMISSION

PSA Public Comment Period ends	(1/21/15)	PSA + 30 days
Parties file Status Reports		1-30-15
Committee Status Conference		2-4-15
SDAPCD files Final Determination of Compliance (FDOC)		Tbd
Staff publishes Final Staff Assessment (FSA)		2-17-15
Parties file Prehearing Statements Identifying Contested Issues, Witnesses, and Exhibits		3-6-15
Prehearing Conference		3-12-15 *
Evidentiary Hearing		3-23-15 – 3-24-15 *
Presiding Member's Proposed Decision (PMPD) Issued for 30 day comment period		4-29-15 *



CALIFORNIA ENERGY COMMISSION

END OF INTRODUCTORY REMARKS



CALIFORNIA ENERGY COMMISSION

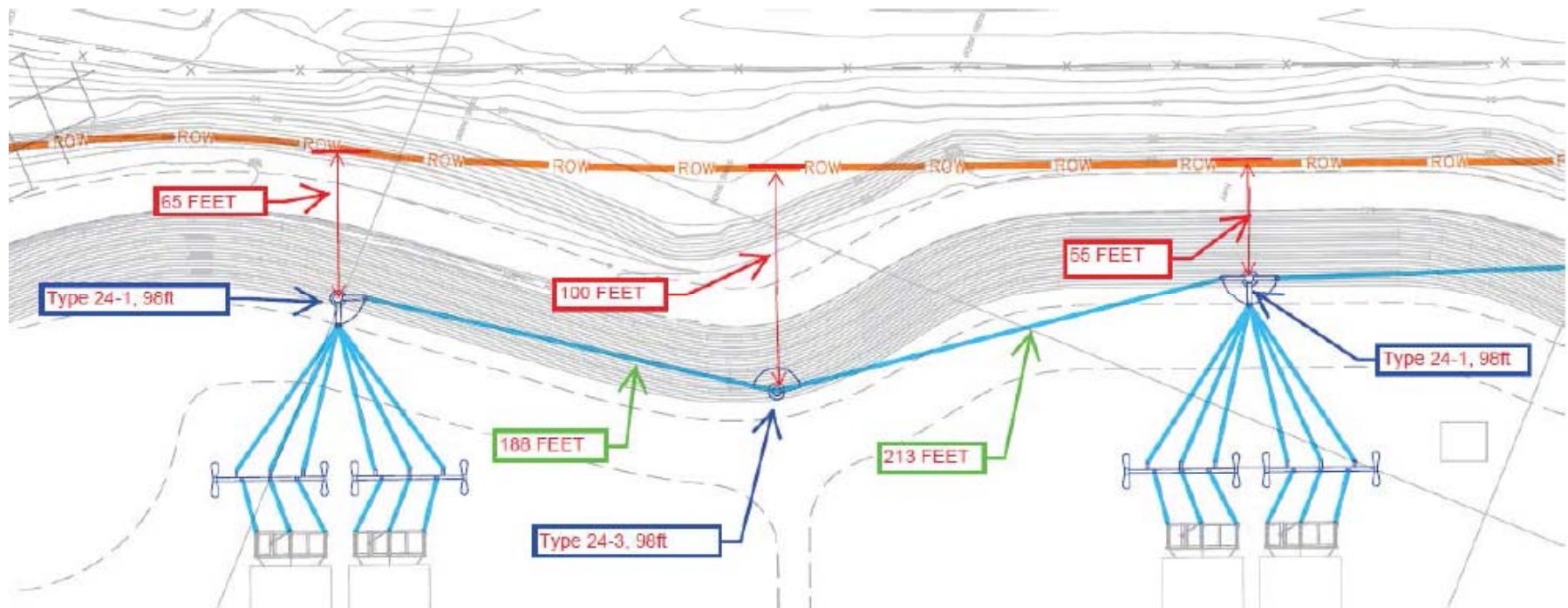



CALIFORNIA ENERGY COMMISSION

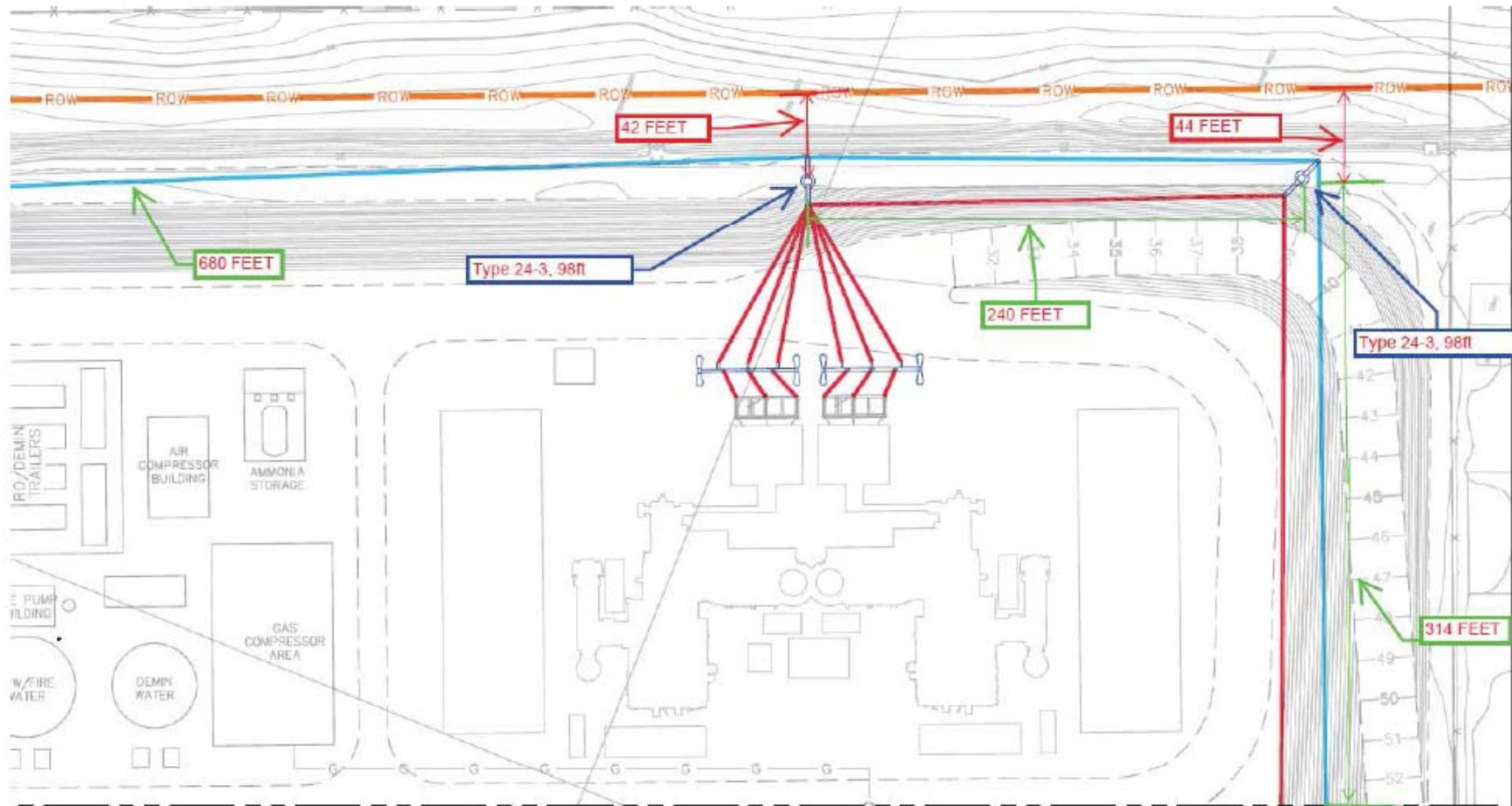

PROJECT DESCRIPTION - FIGURE 6

Carlsbad Energy Center Project Amendment - Reclaimed Water Balance

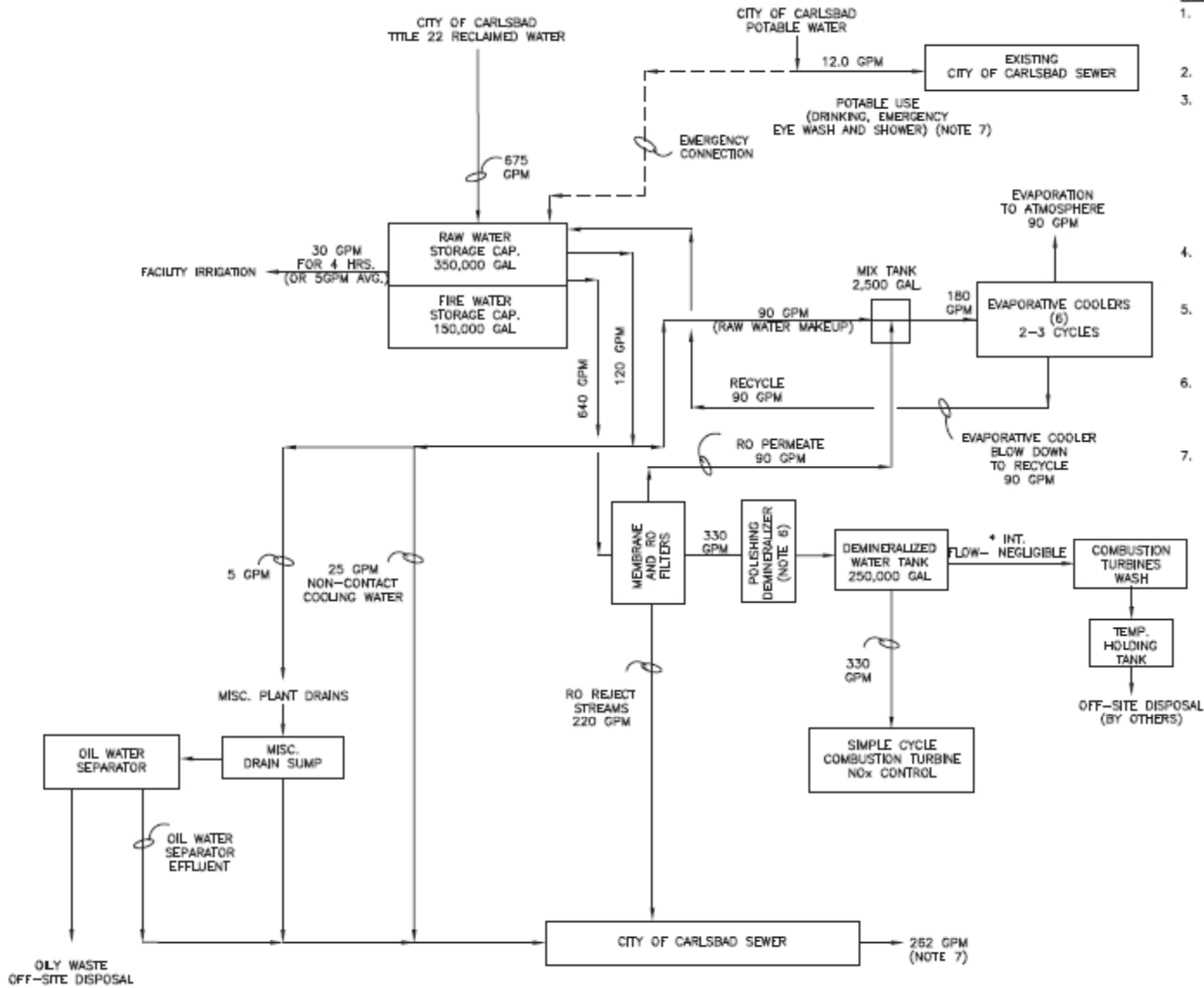

NOTES:

1. DESIGN BASIS:
 - a) NO_x USE - 55 GPM PER TURBINE
 - b) EVAP COOLING USE - 15 GPM PER TURBINE
2. * INT. = INTERMITTENT FLOWS
3. MAXIMUM DAILY CONSUMPTION
 - a) TITLE 22 RECLAIMED WATER 729,000 GALS./DAY
 - b) POTABLE WATER - 17,200 GALS./DAY (NON-FIRE USE)
 - c) POTABLE WATER - EMERGENCY ONLY (FIRE USE)
 - d) FIRE WATER STORAGE REFILL - 500GPM MINIMUM (150,000 GALS./FILL)
4. FLOW RATE (GPM) IS DAILY AVERAGE, BASED ON 18 HR. OPERATION PER DAY. EVAP COOLER ON 18-HRS/DAY.
5. MAXIMUM ANNUAL CONSUMPTION:
 - a) TITLE 22 RECLAIMED WATER - 109,350,000 GALS.
 - b) POTABLE WATER - 2,592,000 GALS.
6. DEMINERALIZER SYSTEM TO CONSIST OF A COMBINATION OF MEMBRANE FILTRATION (MF), REVERSE OSMOSIS (RO) AND A POLISHING DEMINERALIZER.
7. FLOWS INCLUDED IN TOTAL PLANT DISCHARGE TO CITY OF CARLSBAD SEWER



CALIFORNIA ENERGY COMMISSION





Existing

w/ amended CECP and Caltrans comparison

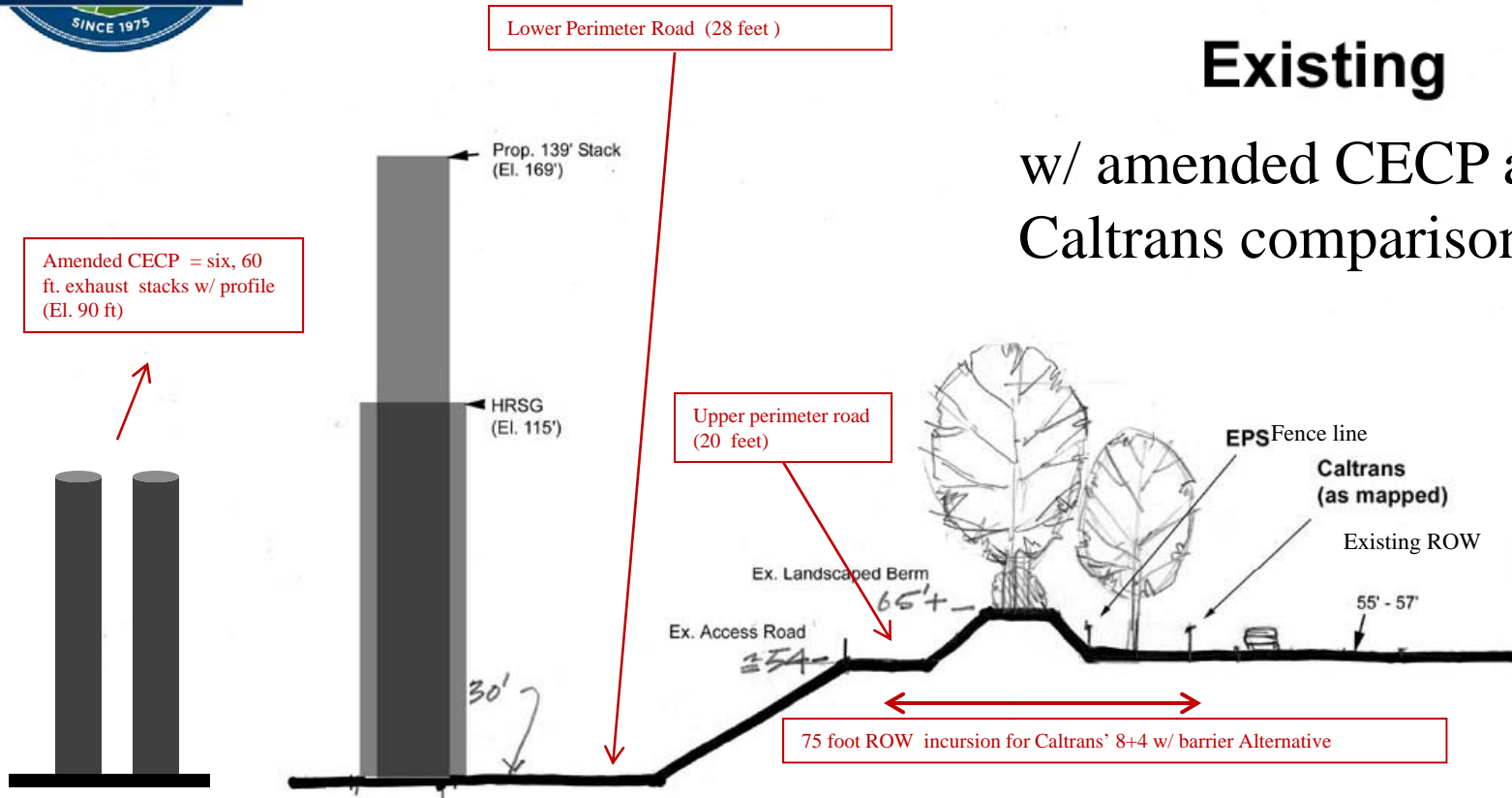



CALIFORNIA ENERGY COMMISSION

Phase IV – Part 1 (Power Plant Building/Stack)



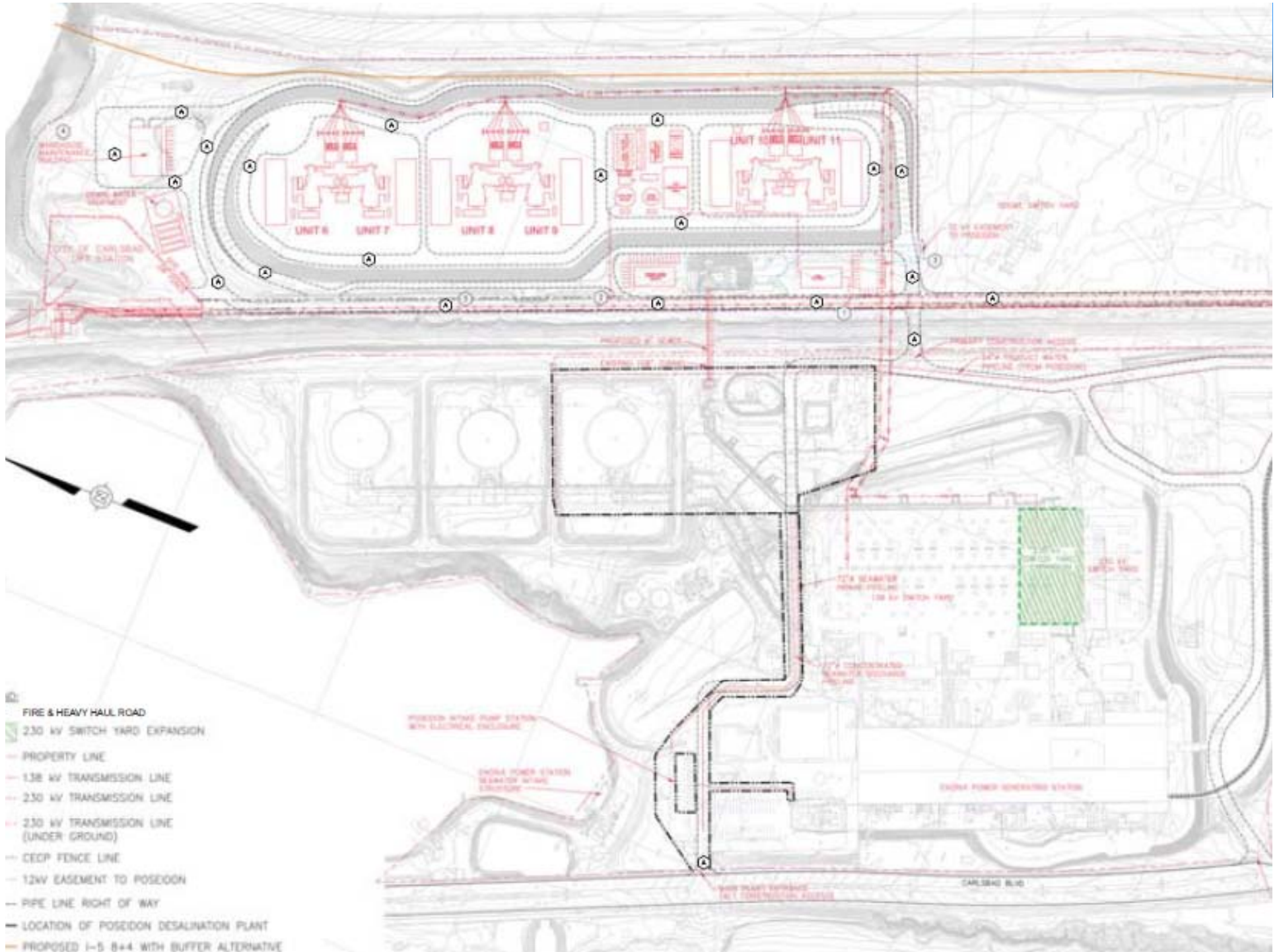

- ① FIRE & HEAVY HALL ROAD
- ▨ 230 KV SWITCH YARD EXPANSION
- PROPERTY LINE
- 138 KV TRANSMISSION LINE
- 230 KV TRANSMISSION LINE
- 230 KV TRANSMISSION LINE (UNDER GROUND)
- CECP FENCE LINE
- 12KV EASEMENT TO POSEDOON
- PIPE LINE RIGHT OF WAY
- LOCATION OF POSEDOON DESALINATION PLANT
- PROPOSED I-5 B+4 WITH BUFFER ALTERNATIVE