

## DOCKETED

<b>Docket Number:</b>	16-AAER-02
<b>Project Title:</b>	Appliance Efficiency Rulemaking for Computers, Computer Monitors, and Signage Displays
<b>TN #:</b>	213578
<b>Document Title:</b>	Generalized Test Protocol for Calculating the Energy
<b>Description:</b>	Generalized Test Protocol for Calculating the Energy Efficiency of Internal Ac-Dc and Dc-Dc Power Supplies, Revision 6.7
<b>Filer:</b>	Harinder Singh
<b>Organization:</b>	California Energy Commission
<b>Submitter Role:</b>	Commission Staff
<b>Submission Date:</b>	9/9/2016 2:31:23 PM
<b>Docketed Date:</b>	9/9/2016

# **Generalized Test Protocol for Calculating the Energy Efficiency of Internal Ac-Dc and Dc-Dc Power Supplies**

**Revision 6.7**

## **EPRI**

Dr. Arshad Mansoor  
Brian Fortenbery  
Baskar Vairamohan  
Tom Geist

## **ecova™**

Peter May-Ostendorp  
Chris Calwell  
Ryan Rasmussen  
Doug McIlvoy  
Jason Boehlke

**March 01, 2014**

## Revision History

---

Version	Release Date	Notes
1.0	Feb 15, 2004	First draft released.
2.0	June 1, 2004	Section on “Product-specific loading guidelines” added.
3.0	Aug 1, 2004	Definitions of measurement parameters modified to match IEEE standard.
4.0	Dec 1, 2004	Comments from Australia on proportional allocation method received. Enhanced proportional allocation method to calculate the power supply loading was included in this revision.
5.0	Aug 1, 2005	Addition of measurement provisions to capture the effects of cyclically operating cooling fans.  Changes in the power measurement accuracy.
6.0	Mar 15, 2006	Scope was modified to focus on internal power supplies that are detachable, have nameplate ratings, and use standard connectors.  Specifications for power measurement equipment refined.  Addition of provisions to guide measurement of power supply ac power consumption during standby mode.
6.1	May 8, 2006	Wiring diagram was modified to reduce possibility for introduction of errors at very low load measurements.
6.2	Nov 30, 2007	Included provision to test power supplies that have options for fan control through external voltage signal
6.3	Apr 24, 2008	The <i>Server Test Protocol Rev 1.2</i> cited in the <a href="http://www.80PLUS.org">http://www.80PLUS.org</a> website is merged with the <i>Generalized Internal Power Supply Efficiency Test Protocol Rev 6.2</i> to form this latest revision of test procedure  Provision to measure dc-dc power supplies is included in this test procedure
6.4	May 28, 2008	Revised paragraphs 4.2, 4.3, 4.4.1, 4.4.2, 4.4.3 to reflect no mention of testing at 100 VAC input, collection of data at 10% of rated load on single output power supplies, and to include collection of fan power data on single output power supplies at all load settings.
6.4.1	Jul 28, 2008	Inclusion of dc-dc power supply testing.

6.4.2	Oct. 13, 2008	Modified paragraphs 1, 2, 3.6, 3.27, 3.28, 4.2.2, 4.4.1, 4.4.2, 5.2, 5.4 Fig.1 & Fig. 2, 5.5, 5.7, 6.1.2, 7.0, 7.1, to include Climate Savers (CSCI, <a href="http://www.climatesaverscomputing.org/">http://www.climatesaverscomputing.org/</a> ) working group comments.
6.4.3	Oct 22, 2009	Modified paragraph 5.5 to include a method to improve the accuracy of power factor measurement of power supplies at low loading conditions.
6.5	July 7, 2010	Included a new paragraph 4.4.4 (Method for Fan Load Power Determination in Storage Power Supplies) specific to the storage power supplies under section 4.4 (Power Supply Fan Control).
6.6	Mar 15, 2012	Included a section 4.4.1 (Power Supply without Internal Fan) which outlines the procedure to test power supplies without internal fan.  Included 10% loading as a part of power supply loading.
6.7	March 01, 2014	Added paragraph 3.8 definition Multiple Input Power Supply  Modified paragraph 4.2.1 (AC Input Voltage and Frequency) to include Multiple input sources and Alternate voltage and frequency selection. Added Table 4-1.  Revised paragraph 4.2.2 to allow test at float voltage, and added Table 4-2.  Not done yet...Added Figure 2 in paragraph 5.2 (Test Voltage Source)

## **Sponsors**

---

The generalized internal power supply efficiency test protocol effort was sponsored by California Energy Commission Public Interest Energy Research (PIER) Program in 2004.

In 2007, the server test protocol was developed which was derived from the generalized power supply efficiency test protocol. This effort was funded by Bonneville Power Administration, Pacific Gas & Electric (PG&E), Natural Resources Canada, The Energy Trust of Oregon, Northwest Energy Efficiency Alliance (NEEA), Snohomish PUD and PacifiCorp.

# TABLE OF CONTENTS

<b>1. SCOPE.....</b>	<b>8</b>
1.1 Intent .....	8
<b>2. REFERENCES .....</b>	<b>9</b>
<b>3. DEFINITIONS.....</b>	<b>10</b>
3.1 Ac-Dc Power Supply .....	10
3.2 Ac Signal.....	10
3.3 Ambient Temperature .....	10
3.4 Apparent Power (S) .....	10
3.5 Dc Signal.....	10
3.6 Dual Input Power Supply .....	<b>Error! Bookmark not defined.</b>
3.7 Efficiency .....	10
3.8 Enclosed-Frame Modular Internal Power Supply .....	10
3.9 Multiple-Output Power Supply .....	10
3.10 Open-Frame Modular Internal Power Supply .....	11
3.11 Output Voltage Bus .....	11
3.12 True Power Factor .....	11
3.13 Crest Factor .....	11
3.14 Rated Ac Input Voltage.....	11
3.15 Rated Ac Input Voltage Range.....	11
3.16 Rated Dc Input Voltage .....	12
3.17 Rated Dc Input Voltage Range.....	12
3.18 Rated Dc Output Current.....	12
3.19 Rated Dc Output Current Range.....	12
3.20 Rated Dc Output Power.....	12
3.21 Rated Dc Output Voltage.....	12
3.22 Rated Input Frequency .....	12
3.23 Rated Input Frequency Range .....	12
3.24 Rated Input Current .....	12
3.25 Rated Input Current Range .....	12
3.26 Rms (Root Mean Square) .....	12
3.27 Single-Output Power Supply.....	13
3.28 Standby Mode .....	13

3.29	Standby Voltage Rail (Vsb) .....	13
3.30	Steady State .....	13
3.31	Test Voltage Source.....	13
3.32	Total Harmonic Distortion (THD) .....	13
3.33	UUT .....	13
3.34	Voltage Unbalance.....	14
<b>4.</b>	<b>STANDARD CONDITIONS FOR EFFICIENCY TESTING .....</b>	<b>15</b>
4.1	General Provisions .....	15
4.2	Input Voltage and Frequency .....	15
4.2.1	Ac Input Voltage and Frequency .....	15
4.2.2	Dc Input Voltage .....	15
4.3	Power Supply Loading.....	16
4.4	Power Supply Fan Control .....	17
4.4.1	Power Supply without Internal Fan.....	17
4.4.2	Multiple-output Power Supply Fan Control through Temperature Sense (Internal Control) 17	
4.4.3	Multiple-output Power Supply Fan Control through External Voltage Signal (External Control) .....	17
4.4.4	Fan Load Considerations for Single-output Power Supplies .....	17
4.4.5	Method for Fan Load Power Determination in Storage Power Supplies.....	18
<b>5.</b>	<b>INSTRUMENTATION AND EQUIPMENT .....</b>	<b>18</b>
5.1	General Provisions .....	18
5.2	Test Voltage Source.....	18
5.3	Test Dc Loads.....	20
5.4	Test Leads and Wiring .....	20
5.5	Measurement Instrumentation Accuracy .....	21
5.5.1	Power Factor (PF) Measurement Accuracy .....	21
5.6	Test Room .....	22
5.7	Warm-up Time.....	22
<b>6.</b>	<b>LOADING CRITERIA FOR EFFICIENCY TESTING .....</b>	<b>23</b>
6.1	General Provisions .....	23
6.1.1	Proportional allocation method for loading multiple and single-output ac-dc and dc-dc power supplies .....	23
6.1.2	Method of Current Allocation for Measuring the Ac or Input Dc Power Consumption of a Computer Internal Power Supply in the Standby Condition .....	27

<b>7.</b>	<b>MEASUREMENT PROCEDURES .....</b>	<b>28</b>
7.1.	Test Report .....	29
<b>8.</b>	<b>APPENDIX A: EXAMPLE EFFICIENCY REPORT FOR A MULTI-OUTPUT POWER SUPPLY.....</b>	<b>30</b>
<b>9.</b>	<b>APPENDIX B: INTERNAL POWER SUPPLY DISCUSSION .....</b>	<b>31</b>
<b>10.</b>	<b>APPENDIX C: SERVER POWER SUPPLY DISCUSSION.....</b>	<b>34</b>



# 1. Scope

This document specifies a test protocol for calculating the energy efficiency of internal ac-dc and dc-dc power supplies. Internal power supplies are located in the same housing as the product that they power. An example of this type of power supply is a desktop computer power supply that has multiple output voltages: +12 V, +5 V, +3.3 V, and -12 V (See Appendix B). External power supplies – often referred to as ac adapters – are contained in a housing separate from the devices they power and are not included in the scope of this document. The test protocol in this document applies specifically to power supplies that meet the following criteria:

- i. Power supplies that have detailed input and output ratings on their name plate or in available literature from their manufacturer, specifying the maximum loads that can safely be placed on each individual dc output voltage bus and, where necessary, groupings of those voltage busses
- ii. Power supplies that have connectors that allow the dc output voltage busses to be connected and disconnected from the powered product non-destructively ( In the event if this is not possible a test board may be provided to enable testing)
- iii. Power supplies that can be easily detached from the housing of the product they power without causing harm to other circuits and components of the product

Power supplies physically integrated within the main circuit board of the device they are powering are specifically not covered by this test procedure, as are power supplies that have a combination of ac and dc output voltage busses. Building upon the efficiency test protocol outlined in Section 4.3 of IEEE Std. 1515-2000, *IEEE Recommended Practice for Electronic Power Subsystems: Parameter Definitions, Test Conditions, and Test Methods*, this test protocol establishes consistent loading guidelines for ac-dc and dc-dc internal power supplies.

## 1.1 Intent

The intent of this document is to use existing industry standards that have been created for electronic test and measurement to develop a consistent and repeatable method for measuring the energy efficiency of single and multiple output ac-dc as well as dc-dc internal power supplies. Existing standards occasionally give conflicting approaches and requirements for efficiency testing, all of which this test protocol seeks to clarify.

## 2. References

The following list includes documents used in the development of this proposed test protocol. If the following publications are superseded by an approved revision, the revision shall apply:

1. IEEE Std 1515-2000, *IEEE Recommended Practice for Electronic Power Subsystems: Parameter Definitions, Test Conditions, and Test Methods*.
2. IEEE Std 519-1992, *IEEE Recommended Practices and Requirements for Harmonic Control in Electrical Power Systems*.
3. IEC 62301 Ed 1.0, *Household Electrical Appliances – Measurement of Standby Power*
4. Draft IEC 62018 Ed. 1, *Energy Management Requirements*.
5. UL 60950, 3<sup>rd</sup> Edition, *Information Technology Equipment – Safety – Part 1: General Requirements*, April 1, 2003.
6. IEC 61000-4-7 Ed.2, *Electromagnetic Compatibility (EMC) - Part 4-7: Testing and Measurement Techniques - General Guide on Harmonics and Interharmonics. Measurements and Instrumentation, for Power Supply Systems and Equipment Connected Thereto*.
7. IEC 61000-3-2, *Electromagnetic Compatibility (EMC) – Part 3-2: Limits – Limits for Harmonic Current Emissions (Equipment Input Current  $\leq 16$  A per Phase)*.
8. IEC 60050, *International Electrotechnical Vocabulary - Electrical and Electronic Measurements and Measuring Instruments*.
9. IEEE 100, *The Authoritative Dictionary of IEEE Standards Terms*.
10. *Power Supply Design Guidelines* (website: <http://www.formfactors.org>), Intel Corporation.
11. *Server System Infrastructure (SSI) Power Supply Design Guidelines* (available at <http://www.ssiforum.org/>), Intel Corporation.
12. IEC 60950-1 Ed 2.0, *Information technology equipment - Safety - Part 1: General requirements, Dec 8, 2005*

### 3. Definitions

For the purpose of this document, the following definitions apply. For terms not defined here, definitions from IEC 60050, IEC 62301, and IEEE 100 are applicable.

#### 3.1 Ac-Dc Power Supply

Devices designed to convert ac voltage into dc voltage for the purpose of powering electrical equipment.

#### 3.2 Ac Signal

A time-varying signal whose polarity varies with a period of time  $T$  and whose average value is zero. (ref. IEEE Std 1515-2000)

#### 3.3 Ambient Temperature

Temperature of the ambient air immediately surrounding the unit under test (UUT). (ref. IEEE Std 1515-2000)

#### 3.4 Apparent Power (S)

The product of RMS voltage and current (VA). Also called the *total power*.

#### 3.5 Dc Signal

A signal of which the polarity and amplitude do not vary with time. (ref. IEEE Std 1515-2000)

#### 3.6 Efficiency

The ratio, expressed as a percentage, of the total real output power (produced by a conversion process) to the real power input required to produce it, using the following equation:

$$\eta = \frac{\sum_i P_{o,i}}{P_{in}} \times 100 \quad \text{Eq. 3-1}$$

where  $P_{o,i}$  is the output power of the  $i^{\text{th}}$  output. The input power ( $P_{in}$ ), unless otherwise specified, includes all housekeeping and auxiliary circuits required for the converter to operate, including any integrated cooling fans for Multiple-output power supplies, and excluding them for Single-output power supplies.

#### 3.7 Enclosed-Frame Modular Internal Power Supply

A power supply encased in a modular enclosure, as shown in Figure B-1 (a). The enclosure is installed inside the appliance and has easily accessible inputs and outputs.

#### 3.8 Multiple Input Power Supply

A power supply designed to operate from multiple galvanically isolated sources and provide power to a common output(s) in one system.

### 3.9 Multiple-Output Power Supply

Power supplies designed to provide most of its rated power on more than one main dc output voltage. There may be other low power dc output voltage(s) for standby power.

### 3.10 Open-Frame Modular Internal Power Supply

A power supply whose components are grouped on a single printed circuit board but are not enclosed in a case, as shown in Figure B-1 (b). Such power supplies are installed inside the appliance that they power, have easily accessible inputs and outputs, and can be separated from the appliance without causing damage to other components and circuits.

### 3.11 Output Voltage Bus

Any of the dc outputs of the power supply, to which loads can be connected and current and power supplied. These busses may supply power at different voltage levels depending on the design of power supply and the product being powered.

### 3.12 True Power Factor

True power factor is the ratio of the active, or real, power (P) consumed in watts to the apparent power (S) drawn in volt-amperes, with

$$PF = \frac{P}{S} \quad \text{Eq. 3-2}$$

and

$$S = \sqrt{P^2 + Q^2} \quad \text{Eq. 3-3}$$

Where

PF is power factor,

P is active power in watts,

Q is reactive power in volt-amperes,

S is total power in Volt-amperes.

This definition of power factor includes the effect of both displacement and distortion in the input current (and/or voltage) waveform. (ref. IEEE Std 1515-2000)

### 3.13 Crest Factor

The crest factor is defined as the ratio of peak current to rms current (or peak voltage to rms voltage). For a pure sinusoidal waveshape the crest factor is 1.414, while for a pure constant dc load the crest factor is 1.0.

### 3.14 Rated Ac Input Voltage

The supply voltage declared by the manufacturer in the specification of the power supply. For a single-phase power supply, this refers to line-to-neutral voltage, and for a three-phase power supply, this refers to the line-to-line voltage.

### 3.15 Rated Ac Input Voltage Range

The supply voltage range (minimum/maximum) as declared by the manufacturer in the specification of the power supply.

### **3.16 Rated Dc Input Voltage**

The nominal dc supply voltage declared by the manufacturer in the specification of the power supply which is typically provided on the power supply nameplate.

### **3.17 Rated Dc Input Voltage Range**

The range of dc input voltage declared by the manufacturer in the specification of the power supply.

### **3.18 Rated Dc Output Current**

The dc output current for each output dc bus of the power supply as declared by the manufacturer in the specification or nameplate of the power supply. If there is a discrepancy between the specification and the nameplate, the nameplate rating shall be used.

### **3.19 Rated Dc Output Current Range**

The dc output current range (minimum/maximum) for each output voltage bus of the power supply as declared by the manufacturer in the specification of the power supply.

### **3.20 Rated Dc Output Power**

The maximum dc output power as specified by the manufacturer. This may apply to the total power for all voltage busses, some subset thereof, or a single voltage bus.

### **3.21 Rated Dc Output Voltage**

The dc output voltage for each output voltage bus of the power supply as declared by the manufacturer in the specification of the power supply.

### **3.22 Rated Input Frequency**

The supply ac input frequency of the power supply as declared by the manufacturer in the specification of the power supply. This is applicable only for ac-dc power supplies.

### **3.23 Rated Input Frequency Range**

The supply ac input frequency range (minimum/maximum) of the power supply as declared by the manufacturer in the specification of the power supply. This is applicable only for ac-dc power supplies.

### **3.24 Rated Input Current**

The input current of the power supply as declared by the manufacturer in the specification of the power supply. For a three-phase supply, rated input current refers to the input current in each phase.

### **3.25 Rated Input Current Range**

The input current range (minimum/maximum) for a power supply as declared by the manufacturer in the specification of the power supply. For a three-phase supply, rated input current refers to the input current in each phase.

### **3.26 Rms (Root Mean Square)**

The square root of the average of the square of the value of the function taken throughout the period. For instance, the rms voltage value for a sine wave may be computed as:

$$V_{RMS} = \sqrt{\frac{1}{T} \int_0^T V^2(t) dt}$$

**Eq. 3-4**

where

$T$  is the period of the waveform,

$V(t)$  is the instantaneous voltage at time  $t$ ,

$V_{RMS}$  is the rms voltage value.

(ref. IEEE Std 1515-2000)

### **3.27 Single-Output Power Supply**

Power supplies designed to provide most of its rated power on one main dc output voltage. There may be other low power dc output voltage(s) for standby power.

### **3.28 Standby Mode**

Standby represents the mode during which all dc power is delivered through the standby voltage rail of the power supply (see Section 3.28).

### **3.29 Standby Voltage Rail (Vsb)**

The standby voltage rail is the output voltage bus that is present whenever ac /or dc power is applied to the input/inputs of the supply. (ref. Intel Power Supply Design Guidelines Rev. 0.5)

### **3.30 Steady State**

The operating condition of a system wherein the observed variable has reached an equilibrium condition in response to an input or other stimulus in accordance with the definition of the system transfer function. In the case of a power supply, this may involve the system output being at some constant voltage or current value. (ref. IEEE Std 1515-2000)

### **3.31 Test Voltage Source**

The test voltage source refers to the device supplying power (voltage and current) to the unit under test (UUT).

### **3.32 Total Harmonic Distortion (THD)**

The ratio, expressed as a percent, of the rms value of an ac signal after the fundamental component is removed to the rms value of the fundamental. For example, THD of current can be defined as:

$$THD_I = \frac{\sqrt{I_2^2 + I_3^2 + I_4^2 + I_5^2 + \dots + I_n^2}}{I_1}$$

**Eq. 3-5**

where  $I_n$  is the rms value of  $n$ th harmonic of the current signal.

### **3.33 UUT**

Unit under test. (ref. IEEE Std 1515-2000)

### 3.34 Voltage Unbalance

The maximum difference between rms phase to neutral or phase-to-phase voltage amplitudes at the UUT input terminals. For example, for a wye-connected, three-phase system

$$V_{UNB} = (\max[V_{AN}, V_{BN}, V_{CN}] - \min[V_{AN}, V_{BN}, V_{CN}]) \quad \text{Eq. 3-6}$$

where

$V_{AN}, V_{BN}, V_{CN}$  are the phase voltage magnitudes, and

$V_{UNB}$  is the maximum phase voltage unbalance.

Percent voltage unbalance is calculated by multiplying the maximum voltage unbalance by 100 and dividing the result by the average of the three phase voltages.

$$V_{UNB\%} = \frac{V_{UNB}}{\left(\frac{V_{AN} + V_{BN} + V_{CN}}{3}\right)} \times 100 \quad \text{Eq. 3-7}$$

(ref. IEEE Std 1515-2000)

## 4. Standard Conditions for Efficiency Testing

### 4.1 General Provisions

Input voltage, frequency, output bus loading, and in some cases, the duty cycle of the fan inside the power supply are among the variables that can impact the efficiency of an internal power supply. Sections 4.2, 4.3, and 4.4 below recommend a minimum set of requirements in order to control these variables while measuring internal power supply efficiency. Beyond these minimum conditions, the manufacturer and user of the power supply may determine additional requirements, such as harmonic distortion or unbalance specification as needed.

### 4.2 Input Voltage and Frequency

#### 4.2.1 Ac Input Voltage and Frequency

An ac reference source shall be used to provide input voltage to the UUT. As is specified in IEC 62301, the input to the UUT shall be the specified voltage  $\pm 1\%$  and the specified frequency  $\pm 1\%$ . The UUT shall be tested at either of two voltage and frequency combinations: 115 V at 60 Hz or 230 V at 60 Hz. If the above is not appropriate use Table 4-1 for the input voltage selection, using the highest voltage/highest frequency combination within the unit rating.

The UUT shall be tested at one of the above voltage and frequency combinations that is closest to its nameplate input voltage and frequency. If voltage and/or frequency ranges are not specified by the manufacturer (or the nameplate value is unclear), the UUT shall not be tested.

Multiple input power supplies may be tested for efficiency using a common AC source capable of meeting the requirements of this paragraph, and Paragraph 5.2. **Table 4-1 Alternate Voltage and Frequency Combinations**

<b>Voltage</b>	<b>Frequency</b>
600 $\Delta$ Vac	60 Hz
600Y / 346 Vac	60 Hz
480 $\Delta$ Vac	60 Hz
480Y / 277 Vac	60 Hz
415 $\Delta$ Vac	60 Hz
415Y / 240 Vac	60 Hz
400 $\Delta$ Vac	50 Hz
400Y / 230 Vac	50 Hz
380Y / 220 Vac	50 Hz or 60 Hz

#### 4.2.2 Dc Input Voltage

A dc reference source shall be used to provide input voltage to the UUT. As is specified in IEC 62301, the input to the UUT shall be the specified Float voltage, unless Nominal is specified,  $\pm 1\%$ . (see Table 4-2 for test voltage using highest voltage within the rating of the unit)



**Note:**

*Efficiency measurement for dc-dc power supplies is carried out in a similar fashion as ac-dc power supplies. In the case of dc-dc power supplies, there will be no specifications for power factor, total harmonic distortion and frequency. There are no changes in the loading calculations for dc-dc power supplies. The efficiency of the dc-dc power supplies is still calculated as the ratio of output (dc) power to the input (dc) power.*

**Table 4-2 Alternate DC Input Voltages**

<b>DC Voltage</b>	<b>Test Voltage</b>	<b>Tolerance</b>
575 V dc	595 V dc	+/- 1%
380 V dc	415 V dc	+/- 1%
60 V dc	66 V dc	+/- 1%
48 V dc	53 V dc	+/- 1%
24 V dc	26 V dc	+/- 1%

### **4.3 Power Supply Loading**

The efficiency of the UUT shall be measured at 10%, 20%, 50% and 100% of rated nameplate output power. Efficiency measurements at lower loading conditions (less than 10% of nameplate output current) may be recorded to support data collection on industry performance of operational efficiency for power supplies that are typically operated in redundant configurations. Other loading conditions may be identified that are relevant to the manufacturer and user of the power supply. For power supply loading purposes, the standby voltage rail is treated as other dc output voltage rails. Procedures for precisely determining load points for server power supplies are described in detail in Section 6.1.1.

In some cases, the manufacturer may specify a minimum current requirement for each bus of the power supply. In these cases, it is important to ensure that calculated current load for a specific load point is not lower than the minimum current requirement (this is of particular concern in lower load conditions such as 5% and 10%). In cases where the minimum current requirement exceeds the test method's calculated load point for a given voltage bus, the value of the minimum current requirement should be used to load the bus rather than the calculated load current. The percent load of the load point shall be properly recorded in any test report based on the new load values used for the busses with minimum loading requirements.

Prior to power measurements, the UUT shall be allowed to operate at each load point for at least 15 minutes in order to allow the power supply to reach a steady state of operation. A steady state of operation has been reached if the total input power reading over two consecutive five-minute intervals does not change by more than  $\pm 1\%$

## **4.4 Power Supply Fan Control**

### **4.4.1 Power Supply without Internal Fan**

In the case where the UUT is not supplied with an internal fan, the manufacturer shall specify the airflow (cubic feet per minute, CFM) necessary to avoid thermal shutdown and an external fan shall be used and powered with an external power source. The power to the external fan is not included within the efficiency calculation because the fan power is part of the nameplate rating of the UUT.

### **4.4.2 Multiple-output Power Supply Fan Control through Temperature Sense (Internal Control)**

In some power supply designs, the duty cycle (expression of percent on time) of a cooling fan is controlled by the temperature of the internal heat sink. If the heat sink inside the power supply reaches a certain set temperature value, the fan switches on. If the heat sink cools down below the set temperature value, the fan switches off. The duty cycle of the fan can then influence the efficiency of the power supply especially during the time of measurement. In order to capture the effect of the duty cycle of the fan on the efficiency of the power supply, the input and output power measurements shall be integrated over a period of 30 minutes<sup>1</sup> (after thermal equilibrium of the power supply is reached) or five fan cycles, whichever is reached first (one fan cycle consists of one on pulse followed by one off pulse). For power measurement procedure refer to section 4 of IEC 62301 (*Measurement of Standby Power*).

### **4.4.3 Multiple-output Power Supply Fan Control through External Voltage Signal (External Control)**

In some power supply designs, there may be provisions for external speed control of power supply fans through an available connector pin. In such cases, the power supply fan is set to run at a default minimum speed preset by the manufacturer. The computing system that houses such power supplies monitors the thermal picture of the system, and when a set of threshold levels are exceeded, a voltage signal is sent to the power supply to increase the speed of the power supply fan. For units with this type of fan speed control, the unit under test will be tested with the *fan speed control pin* set to the DISABLED position, which will set the fan to run at default minimum speed. The fan speed shall not be altered or changed during the course of testing the unit under all loading conditions.

If the manufacturer submitting the unit for test requires any control signal to be applied to the fan speed control pin, the information must be provided at the time of submittal. In this case the power required for the higher speed fan will be included in the efficiency calculation.

### **4.4.4 Fan Load Considerations for Single-output Power Supplies**

In typical single-output power supplies (typically used in the rack mount servers and blade server applications) the fans are sized not only to remove heat from the power supply but also the heat from the system. In order to facilitate the system designer's use of different cooling strategies for

---

<sup>1</sup> Accumulated energy approach to get average power consumption (Please refer to section 4.3, IEC 62301 Ed 1.0): Where the instrument can accumulate energy over a user selected period, the period selected shall not be less than 5 minutes. The integrating period shall be such that the total recorded value for energy and time is more than 200 times the resolution of the meter for energy and time. Determine the average power by dividing the accumulated energy by the time for the monitoring period.

the system, the power consumed by the fan will not be included for efficiency calculations. If the power supply has an internal fan, then the manufacturer will give provision to supply external power to the fan during the power supply efficiency testing. If the power supply does not have an internal fan and if it fails to operate during the efficiency testing due to thermal cutoff, then an external fan shall be used to cool the power supply. The power consumed by the external fan shall not be included in the efficiency calculations. In both cases the fan power used during testing at each load setting will be recorded for data collection in determining industry performance of efficiency with and without fan power.

#### **4.4.5 Method for Fan Load Power Determination in Storage Power Supplies**

Storage system power supplies are different than the single- or multi- output power supplies. They typically are two voltage rail systems (meeting neither single-output nor multi-output definitions) and include a fan(s) that provide cooling air for the storage system as well as the power system. Some of the storage power supplies may have additional outputs as an exception. Measurement of power supply efficiency as an indicator of good energy efficient designs is inaccurate if the power to internal system fans is included.

This protocol will address Storage system power supplies in the same manner as single-output server power supplies. Testing will be done at 230Vac, 60Hz Input. Inclusion or exclusion of fan power in the efficiency calculation will be addressed consistently with existing provisions for single-output and multiple-output power supplies; for storage system power supplies, fan power will be excluded from the efficiency calculation.

Storage system power supplies tested per this protocol must be modified to provide for external power to drive the internal fans. If measuring fan power, or if the required efficiency measurement includes the impact of the fan, the modification must allow internal power supply control of the fan speed and fan power will be measured and recorded at each loading condition.

## **5. Instrumentation and Equipment**

### **5.1 General Provisions**

These procedures are meant to ensure the accurate and consistent measurement of power supplies across testing laboratories. Please refer to Annex B of IEEE 1515-2000, *IEEE Recommended Practice for Electronic Power Subsystems: Parameter Definitions, Test Conditions, and Test Methods*, for guidelines for general test practices and to section 4, Annex B and D of IEC 62301, Ed. 1.0, *Measurement of Standby Power*, for a discussion on evaluating measurement uncertainty.

### **5.2 Test Voltage Source**

The input voltage source shall be deemed inadequate and different voltage source shall be used if the input voltage varies at any point during the test by more than  $\pm 0.1\%$  of the specified source voltage for the test

Regardless of the ac source type, the THD of the supply voltage when supplying the UUT in the specified mode shall not exceed 2%, up to and including the 13<sup>th</sup> harmonic (as specified in IEC 62301). The peak value of the test voltage shall be within 1.34 and 1.49 times its rms value (as specified in IEC 62301).

There are no THD, frequency or voltage unbalance specifications for the dc source.

### 5.3 Test Dc Loads

Active dc loads such as electronic loads or passive dc loads such as rheostats used for efficiency testing of the UUT shall be able to maintain the required current loading set point for each output voltage within an accuracy of  $\pm 0.5\%$ . If electronic load banks are used, their settings should be adjusted such that they provide a constant current load to the UUT.

### 5.4 Test Leads and Wiring

Appropriate American Wire Gauge (AWG) wires have to be selected for different part of wiring connections depending on the maximum current carried by the conductor in order to avoid overheating of wires from excessive loading and to reduce excessive voltage drop across the wires which may lead to incorrect efficiency measurements. For detailed information and guidance on measurement and wiring, please refer to Annex B in IEEE 1515-2000. The Table B.2, “Commonly used values for wire gages and related voltage drops” in IEEE 1515-2000 gives the relation between the voltage drop across the conductor as a function of three variables: current carried by the conductor, conductor AWG, and conductor length. The voltage drop across the conductor carrying the current must be added or subtracted to the appropriate voltage measurements if the input and output measurements of the UUT are not taken directly at the connector pins.

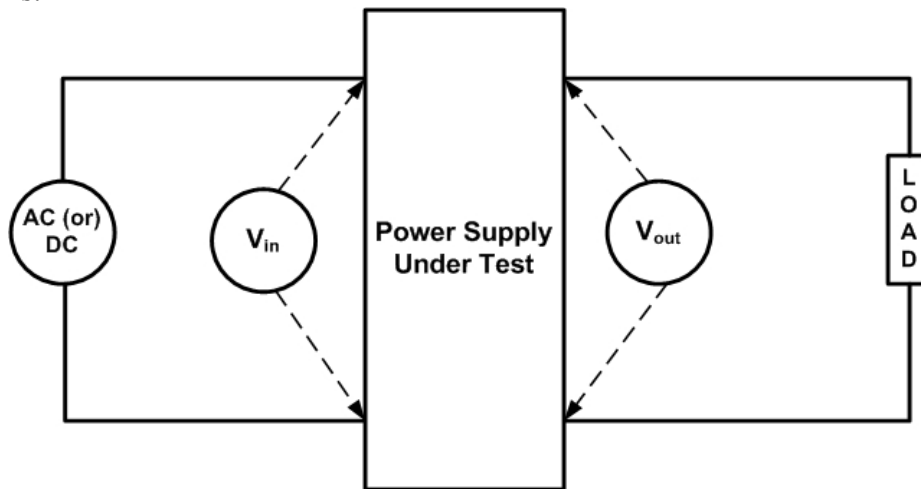

*Figure 1 Input and Output Voltage Measurements*

The generic test setup can be made as shown in Figure 2 below. The ac power meter used in the efficiency test should be capable of measuring the ac voltage, ac current, ac power, power factor, and total harmonic distortion of current. If a dc source is used instead of an ac source, then appropriate dc meter shall be used to measure dc input voltage, current and power. The dc power meter should be capable of measuring dc voltage, dc current, and dc power on all dc voltage inputs or outputs of the device. All power metering equipment should meet the accuracy requirements described in section 5.5 of this document. The dc load(s) shall be capable of drawing constant current during the course of the test and shall meet the tolerances specified in section 5.3 of this document.

**Figure 2 Generic Efficiency Test Setup**

## **5.5 Measurement Instrumentation Accuracy**

Power measurements shall be made with a suitably calibrated voltmeter and ammeter or power analyzer as specified under IEC 62301. Measurements of power of 0.5 W or greater shall be made with an uncertainty of less than or equal to 0.5% at the 95% confidence level.

Measurements of power of less than 0.5 W shall be made with an uncertainty of less than or equal to 0.01 W at the 95% confidence level. Input power shall be made using an averaging technique over a minimum of 32 input cycles utilizing the measurement instrument averaging function.

For appliances connected to more than one phase, the power measurement instrument shall be equipped to measure total power of all phases connected.

Dc measurements for voltage shall have an uncertainty of less than 0.1%. Current and Power measurements shall have an uncertainty of less than 0.5%.

For further details please see Annex D of IEC 62301 and ISO Guide to the Expression of Uncertainty in Measurement.

### **5.5.1 Power Factor (PF) Measurement Accuracy**

Accuracy of power factor (PF) measurements at light loading is dependent upon test setup and noise content of the ac source. Interaction between the ac source and the power factor correction (PFC) circuit can cause an error in PF measurement when using power analyzer instrumentation. This error is significant and can cause as much as 30% error in PF measurements at light loading conditions below 50% of power supply rating. Testing laboratories must ensure that the ac source does not interfere with power factor measurements at light loads. The method to be used in this protocol is described below.

Place a Line Impedance Stabilization Network (LISN) in series with the output of the ac source. The LISN should have 50  $\mu$ Henries inductance in both the Line and Neutral wires. In addition a parallel capacitor should be installed after the LISN and placed as close as possible to the power analyzer input terminals. The capacitor should be 1.0  $\mu$ Farad and rated for a minimum of 250Vac working voltage. The capacitor forms a high frequency circuit with the unit under test, care must

be taken to ensure the cable length from capacitor body to the power analyzer and the cable length from power analyzer to unit under tests is less than *1 meter*. The intent is to minimize the lead inductance between the capacitor and the unit under test. The diagram below (Figure 3) shows the recommended test set up with LISN and the parallel capacitor.

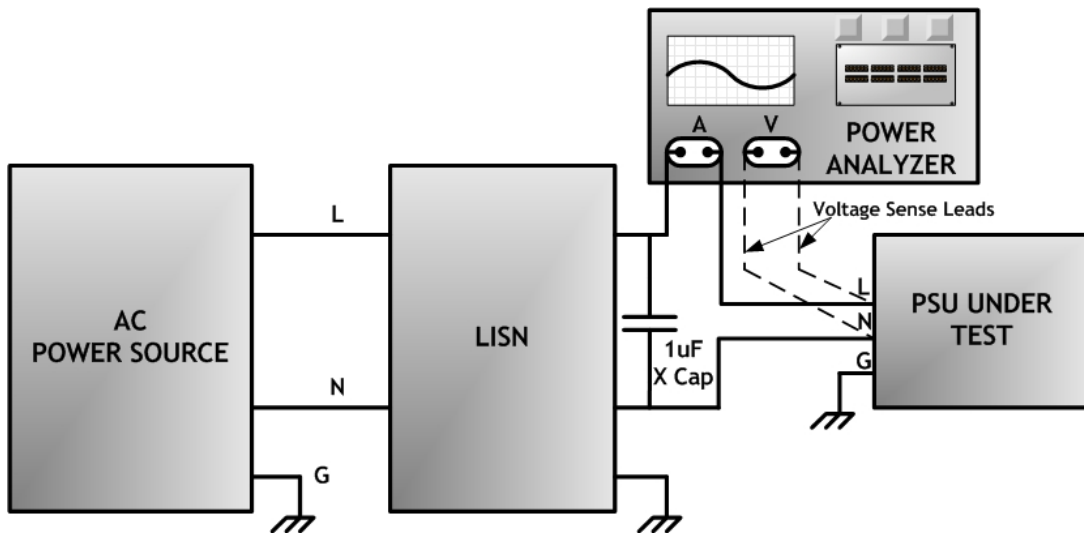

Note: Examples of LISN used:

LISN #1: Rohde & Schwarz ESH3-Z5 10A

LISN #2: Rohde & Schwarz ESH2-Z5 30A

LISN #3: Fischer Custom Communications FCC-LISN-50-32-2-01

LISN #4: Fischer Custom Communications FCC-LISN-50-25-2

**Figure 3 Revised Test Setup to Improve Accuracy of Power Factor Measurement at Light Load Conditions**

## 5.6 Test Room

As is specified in IEC 62301, the tests shall be carried out in a room that has an air speed close to the UUT of  $\leq 0.5$  m/s, and the ambient temperature shall be maintained at  $23^{\circ}\text{C} \pm 5^{\circ}\text{C}$  throughout the test. There shall be no intentional cooling of the UUT by use of separately powered fans, air conditioners, or heat sinks except as specified in Section 4.4.1. The UUT shall be tested on a thermally non-conductive surface.

## 5.7 Warm-up Time

Internal temperature of the components in a power supply could impact the efficiency of the unit. As a general recommendation before testing, each UUT shall be loaded up to the test load for a period of at least 15 minutes or for a period sufficient that the total input power reading over two consecutive five-minute intervals does not change by more than  $\pm 0.2\%$ .

## 6. Loading Criteria For Efficiency Testing

### 6.1 General Provisions

Loading criteria for ac-dc or dc-dc power supplies shall be based on rated dc output current and not on rated dc output power. For example, consider the 50% loading condition for a 50 W, +5 V single-output power supply with a rated dc output current of 10 A. The load condition is achieved by adjusting the dc load (using a rheostat or electronic load bank) connected to the 5 V bus output so that 5 A of current is flowing on the bus. This is *not* equivalent to adjusting the load bank until the load on that bus dissipates 25 W of power, because voltage regulation may not remain constant under a range of loading conditions.

For power supplies with multiple output voltage busses, defining consistent loading criteria is much more difficult, because each bus has a rated dc output current. The sum of the power dissipated from each bus loaded to these rated currents may exceed the overall rated dc output power of the power supply. A proportional allocation method is recommended for providing consistent loading guidelines for multiple output internal ac-dc power supplies. This method is described in detail in the next section.

#### 6.1.1 ***Proportional allocation method for loading multiple and single-output ac-dc and dc-dc power supplies***

This section shows a procedure for developing loading guidelines based on a proportional allocation method. Required measurements shall be taken at loading points 20%, 50% and 100% of rated output power. A measurement at 10% may be recorded for both single and multi-output power supplies. The UUT's nameplate specifies the maximum rated dc output current on each output voltage bus, and care should be taken not to exceed those values. However, loading the busses to their *individual* current maximums often will exceed the *overall* rated dc output power of the power supply. In some cases, ratings are established for a subgroup of the output voltage busses. These *subgroup* ratings can also be exceeded if the busses are loaded to their *individual* current maximums. The following sections provide procedures for loading multiple-output ac-dc power supplies by using a calculated derating factor ( $D$ ).

##### 6.1.1.1 Method of Proportional Allocation Based on Overall Power Supply Rated Dc Output Current With No Sub-group Ratings

The manufacturer has provided rated dc output current limits for each bus and an overall rated dc output power for the power supply. The approach for loading criteria is as follows:

Assume a power supply with four output voltage busses. A sample output specification of this power supply is shown in Table 6-1.



**Table 6-1: Labels for Output Variables**

Rated Dc Output Voltage of Each Bus	Rated Dc Output Current of Each Bus	Rated Overall Dc Output Power
$V_1$	$I_1$	$P$
$V_2$	$I_2$	
$V_3$	$I_3$	
$V_4$	$I_4$	

**Step 1:** Calculate the derating factor  $D$  using the procedure outlined in Eq. 6-1.

$$D = \frac{P}{(V_1 * I_1) + (V_2 * I_2) + (V_3 * I_3) + (V_4 * I_4)} \quad \text{Eq. 6-1}$$

**Step 2:** If  $D \geq 1$ , then it is clear that loading the power supply to the rated dc output current for every bus does not exceed the overall rated dc output power for the power supply. For this case, the required output dc current on each bus for  $X\%$  loading can be determined by

$$I_{bus} = I_n * \frac{X}{100} \quad \text{Eq. 6-2}$$

where  $I_{bus}$  is the required output dc current for that bus at  $X$  percent load and  $I_n$  is the rated dc output current for that bus. For example, Table 6-2 shows the guideline for 50% loading of the power supply based on  $D \geq 1$ .

**Table 6-2: 50% Loading Guideline for  $D \geq 1$**

Output Voltage of Each Bus	50% Loading Guideline
$V_1$	$0.5 * I_1$
$V_2$	$0.5 * I_2$
$V_3$	$0.5 * I_3$
$V_4$	$0.5 * I_4$

**Step 3:** If, however,  $D < 1$ , it is an indication that loading each bus to its rated dc output current will exceed the overall rated dc output power for the power supply. In this case, the following loading criteria using the derating factor can be adopted:

$$I_{bus} = \frac{D * X * I_n}{100}$$

**Eq. 6-3**

This effectively derates the output dc current of each output voltage bus such that at 100% load, the overall load will equal the rated dc output power of the power supply. It also derates other load levels. For example, Table 6-3 shows the guideline for 50% loading of the power supply based on  $D < 1$ .

**Table 6-3: 50% Loading Guideline for  $D < 1$**

Output Voltage of Each Bus	50% Loading Guideline
$V_1$	$D*0.5*I_1$
$V_2$	$D*0.5*I_2$
$V_3$	$D*0.5*I_3$
$V_4$	$D*0.5*I_4$

#### 6.1.1.2 Method of Proportional Allocation Based on Overall Power Supply Rated Dc Output Current with Sub-group Ratings

In some cases, the power supply manufacturer specifies the rated dc output power for a subgroup of busses in addition to the overall rated dc output power of the power supply. An example of this type of power supply is a computer power supply with an overall rated dc output power of 330 W and a rated dc output power of 150 W for the +5 V and +3.3 V busses combined. Loading each bus to its individual rated dc output current may now exceed both the overall power supply's rated dc output power and the subgroup's rated dc output power. This section outlines a procedure for ensuring that both the subgroup and overall current ratings are not exceeded.

Assume a power supply with six output voltage busses with an overall rated dc output power  $P_T$ . Let the rated dc output power for subgroup busses 1 and 2 be  $P_{S1-2}$  and a rated power for subgroup busses 3 and 4 be  $P_{S3-4}$  and the ratings for bus 5 and 6 be simply equal to the product of their individual voltages and currents. A sample output specification of this power supply is shown in Table 6-4.

**Table 6-4 Output Variable Labels for Maximum Rating of Subgroup Output Voltage Bus**

Output Voltage of Each Output Bus	Maximum Rated Output Current of Each Bus	Maximum Rated Output Wattage for Subgroups $V_1, V_2$ and $V_3, V_4$	Maximum Power Supply Total Rating
$V_1$	$I_1$	$P_{S1-2}$	$P_T$
$V_2$	$I_2$		
$V_3$	$I_3$	$P_{S3-4}$	
$V_4$	$I_4$		
$V_5$	$I_5$	$P_{S5}$	
$V_6$	$I_6$	$P_{S6}$	

**Step 1:** Calculate derating factors  $D_{S1}$  to  $D_{S6}$  for each of the subgroups as shown in Eq. 6-4.

$$\begin{aligned}
 D_{S1-2} &= \frac{P_{S1-2}}{(V_1 * I_1 + V_2 * I_2)} \\
 D_{S3-4} &= \frac{P_{S3-4}}{(V_3 * I_3 + V_4 * I_4)} \\
 D_{S5} &= \frac{P_{S5}}{(V_5 * I_5)} \\
 D_{S6} &= \frac{P_{S6}}{(V_6 * I_6)}
 \end{aligned}
 \tag{Eq. 6-4}$$

If the derating factor  $D_S \geq 1$ , then it is clear that when the subgroup is loaded to the rated dc output currents, the subgroup rated output powers will not be exceeded and there is no need for derating.

However, if one or more  $D_S$  factors are less than 1 then the subgroup power will be exceeded if the outputs are loaded to their full output currents and there is a need for derating.

**Step 2:**

There is also a need to check whether the sum of the subgroup maximum rated powers is greater than the total maximum power rating of the power supply ( $P_T$ ). If the sum of the subgroup maximum rated powers is greater than the overall power rating of the power supply then a second derating factor  $D_T$  must be applied. This factor is calculated as shown below:

$$D_T = \frac{P_T}{P_{S1-2} + P_{S3-4} + P_5 + P_{S6}}
 \tag{Eq. 6-5}$$

If  $D_T \geq 1$  then no derating is needed.

If  $D_T < 1$  then the derating for each of the outputs has to be applied and is shown below.

For example, Table 6-5 shows the guideline for X% loading of the power supply based on  $D_S < 1$  and  $D_T < 1$ .

**Table 6-5 Output Loading Current Calculation for Each Individual and Sub-group Bus Voltages**

Output Voltage	Output Current Rating	Subgroup	Output Loading Current
V <sub>1</sub>	I <sub>1</sub>	1-2	$D_T * D_{S1-2} * I_1 * \frac{X}{100}$
V <sub>2</sub>	I <sub>2</sub>		$D_T * D_{S1-2} * I_2 * \frac{X}{100}$
V <sub>3</sub>	I <sub>3</sub>	3-4	$D_T * D_{S3-4} * I_3 * \frac{X}{100}$
V <sub>4</sub>	I <sub>4</sub>		$D_T * D_{S3-4} * I_4 * \frac{X}{100}$
V <sub>5</sub>	I <sub>5</sub>	5	$D_T * D_{S5} * I_5 * \frac{X}{100}$
V <sub>6</sub>	I <sub>6</sub>	6	$D_T * D_{S6} * I_6 * \frac{X}{100}$

**6.1.2 Method of Current Allocation for Measuring the Ac or Input Dc Power Consumption of a Computer Internal Power Supply in the Standby Condition**

Measurement of the ac or input dc power consumption of computer internal power supplies operated in standby mode shall be conducted by connecting the power supply to an ac or dc voltage source, as appropriate, through its power input and applying the following current loads to its standby voltage rail/rails that represent 20%, 50%, and 100% of its nameplate rated load currents. (ref. Intel Power Supply Design Guidelines Rev. 0.5)

For power supplies designed to power other electronic products, measurement of the ac or input dc power consumption in standby mode shall be conducted by connecting the power supply to an ac or dc voltage source, as appropriate, through its power input and applying current loads to the standby voltage rail equal to 20%, 50%, and 100% of its nameplate current rating. Testers may choose to test the ac or dc input power consumption during standby mode at other load points *in addition* to the above recommended load points if these loads better characterize the real loads placed on the standby voltage rail when installed in its intended product.

## 7. Measurement Procedures

1. Record all the input and output specifications of the ac-dc or dc-dc power supply provided by the manufacturer in the power supply specification sheet. These may include one or more of the following specifications:
  - Rated input voltage (ac or dc)
  - Rated input voltage range (ac or dc)
  - Rated input current (ac or dc)
  - Rated input current range (ac or dc)
  - Rated input frequency (not applicable to dc input)
  - Rated input frequency range (not applicable to dc input)
  - Rated output dc power
  - Rated output dc current
  - Rated output dc current range
  - Rated output dc voltage
  - Rated output dc voltage range
  - Record the ambient temperature at the site of the test.
2. Calculate the loading criteria for each output voltage bus for each loading level defined by the loading guidelines used for the UUT.
3. Complete the test setup with the source, UUT, load, and measurement instrumentation. Refer to IEEE 1515 Annex B, General Test Practices, for general guidelines and recommended practices for measurement and instrumentation setup for testing power supplies.
4. Set the power source input voltage and frequency (if programmable) as per the test requirement.
5. Load the output voltage busses (using either a rheostat or an electronic dc load bank) based on the loading criteria established for the UUT within the tolerance levels specified in this protocol.
6. If the fan turns on intermittently, then follow the procedure outlined in section 4.4.
7. Measure and record the following at each load condition with the minimum resolution as indicated below. Record the instrumentation used and the range setting for each reading. Record the actual point of measurement for each reading.. For dc values, record separate values for each dc output voltage bus:
  - Average ac input power or dc input power in case of dc-dc power supplies (four significant digits)
  - Rms ac input voltage or dc input voltage (four significant digits)
  - Rms ac input current or dc input current (four significant digits)
  - Power factor ( two significant digits) not applicable to dc-dc power supplies

- Total harmonic distortion of input current (three significant digits) for ac input only.
  - Dc output voltage (four significant digits)
  - Dc output current (four significant digits)
  - Dc output power
  - *Note: Power Factor and total harmonic distortion are not applicable to dc-dc power supplies*
8. Calculate the efficiency of the power supply for the loading condition using the equation:

$$\eta = \frac{\sum_i P_{o,i}}{P_{in}} \times 100 \quad \text{Eq. 7-1}$$

Where,  $P_{in}$  is the recorded input power and  $P_{o,i}$  is the output power of the  $i^{\text{th}}$  bus.

9. Repeat this procedure for other loading conditions.
10. Measure and record the power consumption of the UUT in standby mode at the load points specified in section 6.1.2 of this document.

*Note: When testing for efficiency of data center power supplies at light loads the accuracy may be impacted by circuit operating states. It is possible that the synchronous rectification circuitry may begin operation in a discontinuous mode and cause lower efficiency readings.*

## 7.1. Test Report

In the test report, graphically display the key data (measured and calculated) from the test along with a description of the power supply that includes the manufacturer's model name and model number, specifications, and loading criteria. Include in the test report footnotes or an appendix that records instrumentation used, range settings for each measurement, and measurement location for each recorded measurement. Appendix A provides an example test report for an ac-dc power supply and a graphical representation of power supply efficiency under different loading conditions. For additional information on power supply test reports and other relevant information, refer to the website <http://www.efficientpowersupplies.org>.

## 8. Appendix A: Example Efficiency Report for a Multi-Output Power Supply

### 80 PLUS Verification and Testing Report

TYPICAL EFFICIENCY (50% Load):	87.69%
AVERAGE EFFICIENCY :	85.97%
80 PLUS COMPLIANT:	YES



Ecos ID #	XXXX
Manufacturer	ABC CORP
Model Number	MODEL750
Serial Number=	N/A
Year	2012
Type	ATX12V
Test Date	1/20/2012

Rated Specifications	Value	Units
Input Voltage	100-240	Volts
Input Current	9.5	Amps
Input Frequency	50-60	Hz
Rated Output Power	750	Watts

Note: All measurements were taken with input voltage at 115 V nominal at 60 Hz.

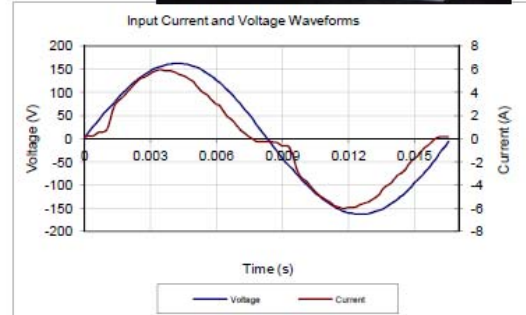

Input AC Current Waveform (ITHD = 19.14%, 50% Load)

I <sub>RMS</sub> A	PF	I <sub>THD</sub> (%)	Load (%)	Input Watts	DC Terminal Voltage (V)/ DC Load Current (A)				Output Watts	Efficiency %	
					12V (cumulative of 12V1, 12V2, etc.)	-12V	3.3V	5V			5Vsb
0.89	0.92	37.84%	10%	94.40	12.2/5.3	12.1/0	3.4/1.2	5.1/1.2	5/0.3	76.49	81.03%
1.63	0.94	30.88%	20%	176.90	12.2/10.6	12.1/0	3.4/2.5	5.1/2.5	5/0.5	152.58	86.25%
3.87	0.97	19.14%	50%	433.90	12.1/26.5	12.2/0.1	3.4/6.1	5/6.1	5/1.3	380.49	87.69%
7.91	0.99	13.24%	100%	898.50	12.1/52.8	12.3/0.3	3.3/12.2	5/12.3	4.9/2.5	754.41	83.96%

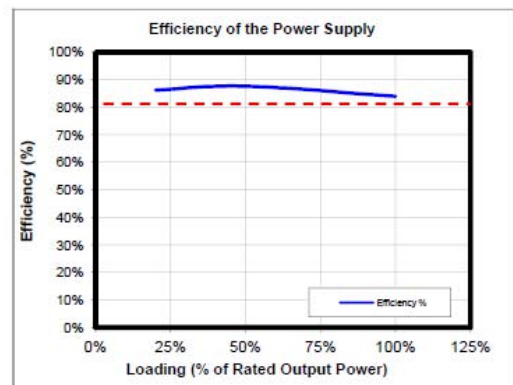
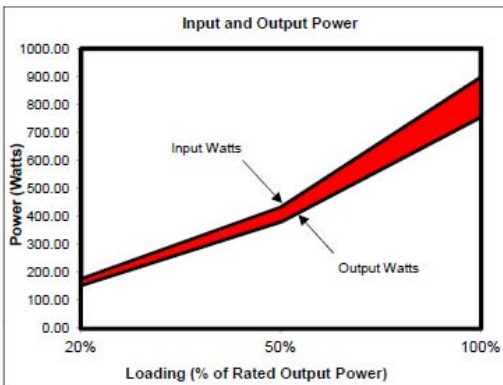

These tests were conducted by a third party independent testing firm on behalf of the 80 PLUS Program. 80 PLUS is a certification program to promote highly-efficient power supplies (greater than 80% efficiency in the active mode) in technology applications. <http://www.80plus.org/>



Include latest report and the correct web link address

## 9. Appendix B: Internal Power Supply Discussion

The common housing structures for internal power supplies considered in this test procedure are enclosed-frame and open-frame as shown in the Figure B-1. Internal power supplies within an enclosure could be fan-cooled.



**(a) Enclosed Frame Internal Power Supplies**



**(b) Open-frame Internal Power Supplies**

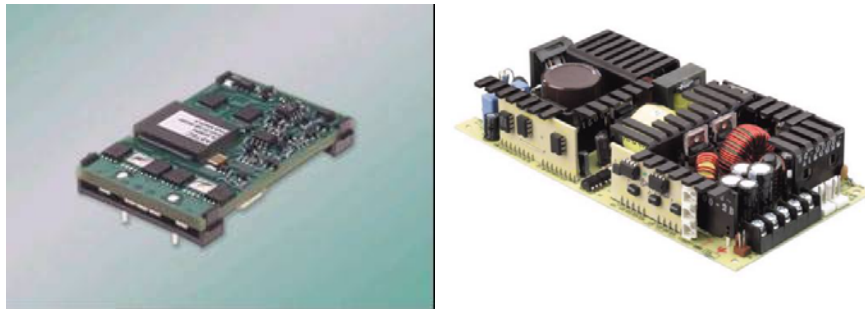

**Figure B-1. Examples of a) enclosed frame and b) open frame internal power supplies (Courtesy Astec Power, Artesyn Technologies)**

Output ratings of a cross-section of internal power supplies used in various product classes and their loading criteria are shown in the tables below.



**Table B-1: output specification of a 300 W internal power supply for an ATX 12 V form factor desktop personal computer**

<b>Voltage Rail Number</b>	<b>Output Voltage</b>	<b>Min. Current (A)</b>	<b>Max. Current (A)</b>	<b>Peak Current (A)</b>
V <sub>1</sub>	+12	1.0	18.0	19.5
V <sub>2</sub>	+5	0.5	26.0	--
V <sub>3</sub>	+3.3	0.5	27.0	--
V <sub>4</sub>	-12	0.0	0.8	--
V <sub>5</sub>	+5 (Standby)	0.0	2.0	2.5

**Table B-2: output specification of a 220 W internal power supply for an TFX 12 V form factor desktop personal computer**

<b>Voltage Rail Number</b>	<b>Output Voltage</b>	<b>Min. Current (A)</b>	<b>Max. Current (A)</b>	<b>Peak Current (A)</b>
V <sub>1</sub>	+12	1.0	15	17
V <sub>2</sub>	+5	0.3	13	--
V <sub>3</sub>	+3.3	0.5	17	--
V <sub>4</sub>	-12	0.0	0.3	--
V <sub>5</sub>	+5 (Standby)	0.0	2.0	2.5

**Table B-3: Output specification of a 200W internal power supply for a cathode Ray Tube (CRT) Display**

<b>Voltage Rail Number</b>	<b>Dc Bus Voltage (V)</b>	<b>Continuous Current Rating (A)</b>	<b>Required Voltage Regulation</b>
V <sub>1</sub>	135	0.75	+/- 1V
V <sub>2</sub>	30	1.2	5%
V <sub>3</sub>	15	0.5	5%
V <sub>4</sub>	7	1.2	5%

**Table B-4: Output specification of a 55W internal power supply for a Liquid Crystal Display (LCD)**

<b>Voltage Rail Number</b>	<b>Dc Bus Voltage (V)</b>	<b>Continuous Current Rating (A)</b>	<b>Required Voltage Regulation</b>
V <sub>1</sub>	12	1.2	5%
V <sub>2</sub>	5	8	3%

**Table B-5: Output specification of a 360W internal power supply for a Plasma Display Panel (PDP)**

<b>Voltage Rail Number</b>	<b>Dc Bus Voltage (V)</b>	<b>Continuous Current Rating (A)</b>	<b>Required Voltage Regulation</b>
V <sub>1</sub>	170	1.3	+/- 2V
V <sub>2</sub>	65	0.9	5%
V <sub>3</sub>	15	0.9	5%
V <sub>4</sub>	13.5	0.6	7%
V <sub>5</sub>	12	0.6	5%
V <sub>6</sub>	5	0.7	5%
V <sub>7</sub>	5 (standby)	0.15	5%

**Table B-6: Output specification of a 30W internal power supply for a digital set top box**

<b>Voltage Rail Number</b>	<b>Dc Bus Voltage (V)</b>	<b>Continuous Current Rating (A)</b>
V <sub>1</sub>	30	0.03
V <sub>2</sub>	18	0.5
V <sub>3</sub>	12	0.6
V <sub>4</sub>	5	3.2
V <sub>5</sub>	3.3	3.0

## 10. Appendix C: Server Power Supply Discussion

The common housing structures for server power supplies considered in this test procedure are rack-mountable units as shown in Figure C-1.

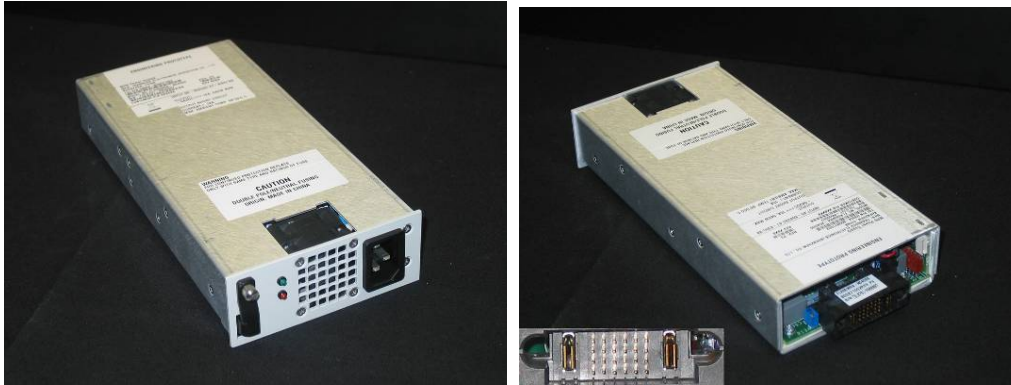

**(a) Single Output Server Power Supply: -54VDC**

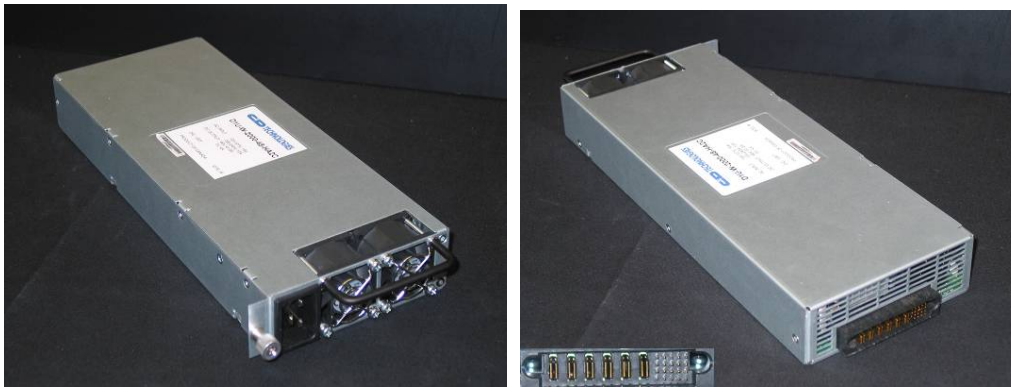

**(b) Dual Output Server Power Supply: 48VDC and 5VDC**



**(c) Multiple Output Server Power Supply: 12VDC, 5VDC, 3.3VDC & -12VDC**

**Figure C-1. Examples of rack-mountable server power supplies that have (a) single output (TDI), (b) dual outputs (C & D Technologies), and (c) multiple outputs (Delta Electronics)**

Each of the three server power supplies shown in Figure C-1 has a unique output connector interface, resulting in an additional step necessary to measure their efficiencies.

Examples of server power supplies operating in a data center are shown in Figure C-2. Notice how power supplies are configured redundantly such that two individual power supplies power one single server or server bank. If one of the power supplies fails, the other will assume the entire load. This scheme protects data center operators from unnecessary downtime.

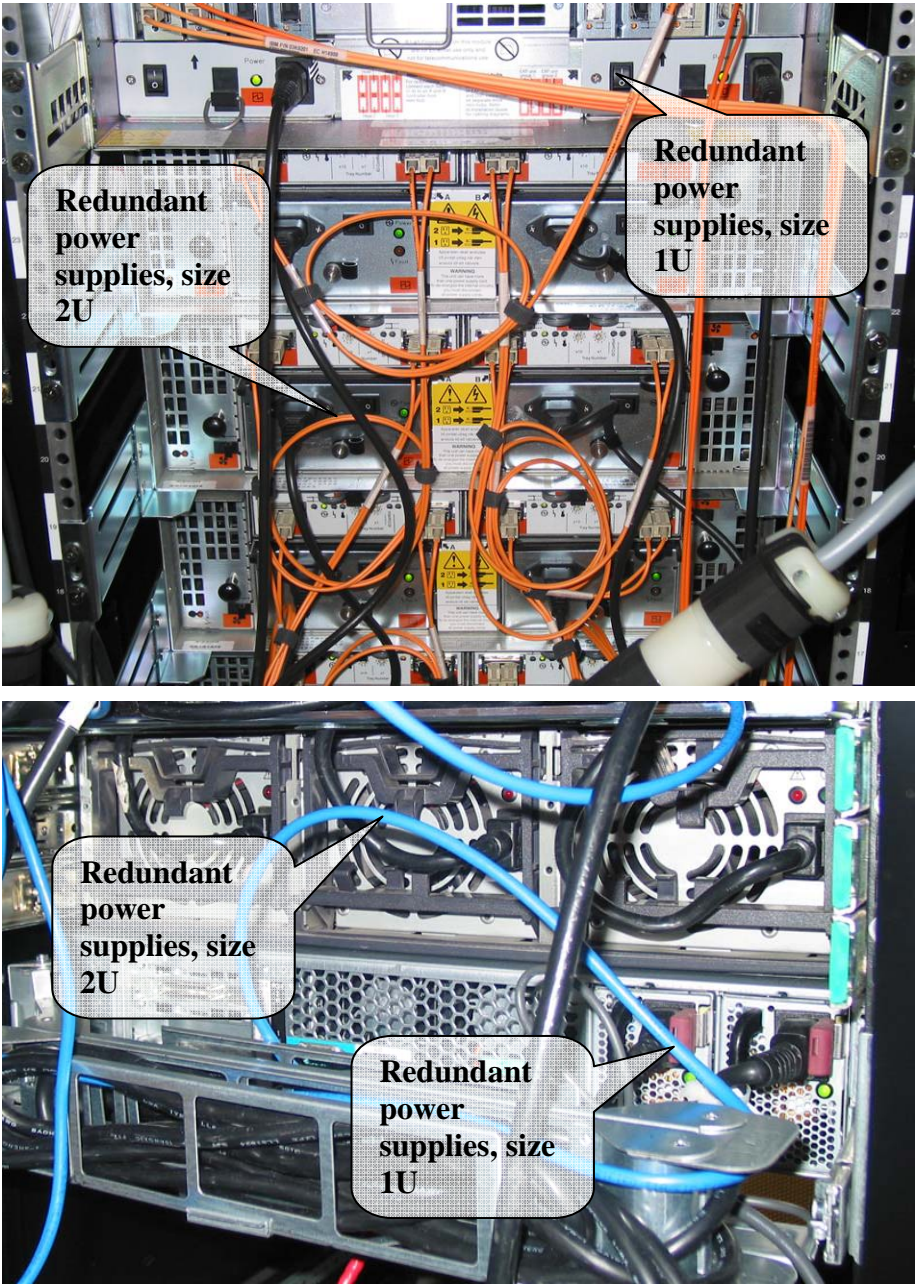

**Figure C-2. Examples of redundant server power supplies in a data center (courtesy of Electric Power Research Institute)**

Server power supplies vary widely in their nameplate characteristics, such as output power and voltage. A representative sample of one-unit (1U) rack-mountable server power supplies and their nameplate ratings are listed in Table C-1.

**Table C-1: Specifications of a sample of server power supplies**

<b>Manufacturer</b>	<b>Rated Output Power (W)</b>	<b>Size</b>	<b>Category</b>	<b>Voltage Outputs (V dc)</b>
A	1325	1U	Dual Output	12V, 3.3V
B	1900	3U	Single Output	48V
C	540	1U	Single Output	-54V
D	500	1U	Multiple Output	12V, 5V, 3.3V, -12V, 5Vsb
E	750	2U	Multiple Output	12V, 5V, 3.3V, -12V, 5Vsb
F	2000	1U	Dual Output	48V, 5V