

DOCKETED	
Docket Number:	24-OPT-03
Project Title:	Soda Mountain Solar
TN #:	268998
Document Title:	Updated Preliminary Drainage Report (Part 1)
Description:	This docket item provides an updated Preliminary Drainage Report (Part 1) in response to the email from the CEC dated March 9, 2026.
Filer:	Hannah Arkin
Organization:	Resolution Environmental
Submitter Role:	Applicant Representative
Submission Date:	3/11/2026 9:14:49 AM
Docketed Date:	3/11/2026



PRELIMINARY DRAINAGE REPORT

for

Soda Mountain Solar Project

San Bernadino County, California

Prepared for:

Apex Energy Solutions, LLC

Attn: Ziad Alaywan

604 Sutter Street, Suite 250

Folsom, CA 95630

March 2026

Prepared by:

Tory R. Walker, PE





TABLE OF CONTENTS

1. INTRODUCTION.....	1
2. PROJECT DESCRIPTION.....	1
2.1. Pre-Project Conditions.....	2
2.2. Post-Project Conditions.....	3
3. HYDROLOGIC ANALYSIS.....	3
3.1. Peak Design Storm Calculations.....	4
3.2. Peak Flow Summary.....	5
4. HYDRAULIC ANALYSIS.....	5
5. RESULTS AND CONCLUSIONS.....	6
6. REFERENCES.....	7

TABLES

Table 1 Summary of AES Inputs.....	5
Table 2 100-Year Peak Flow Rate.....	5

ATTACHMENTS

- ATTACHMENT 1 Soils Map
- ATTACHMENT 2 Rational Method Calculations
- ATTACHMENT 3 SWCA Drainage Report



1. INTRODUCTION

The purpose of this report is to summarize the CEQA level (preliminary) hydrologic and hydraulic analyses of the proposed Soda Mountain Solar project. This report analyzes the following:

1. Pre and post-project drainage conditions for a 100-year design storm

2. PROJECT DESCRIPTION

Soda Mountain Solar, LLC, is proposing a solar power production facility in the Soda Mountain area of San Bernardino County, California. Tory R. Walker Engineering (TRWE) conducted a stormwater drainage analysis to evaluate potential significant hydrologic or hydraulic impacts onsite or offsite.

The Soda Mountain Solar project proposes to construct solar arrays on the property, with battery energy storage systems (BESS), a substation, laydown yards, and roadways to support the operations. Proposed hydraulic components, where necessary, include swales, berms, and rock lining along roadways.

The project site is approximately 2,670 acres and is 6 miles southwest of Baker, California, along Interstate 15. The study area contains numerous alluvial fans that drain toward the proposed site. See Location Map in **Figure 1** below.



Figure 1 | Location Map

2.1. Pre-Project Conditions

The project site is currently 100% pervious, consisting primarily of barren land and open brush. The entire site is underlain by NRCS Hydrologic Soil Group A, as classified by the USDA Web Soil Survey. See Soils Map in **Attachment 1**. Stormwater runoff on the project site flows overland toward the east, with the majority of the project draining south and a portion of the site draining north. Offsite run-on enters the site from the west through three culverts along I-15.

The surrounding terrain is characterized by numerous alluvial fans that drain toward the proposed development area in the valley floor. These individual alluvial fans have coalesced, or overlapped, along the base of the mountain fronts surrounding the project site, creating a broad, gently sloping depositional surface, known as a bajada.

Terrain plays a major role in how runoff behaves because it influences the speed, volume, and direction of water flow during precipitation events. Steeper slopes accelerate water movement,



reducing infiltration and increasing runoff volume and velocity. Gentler slopes allow more time for water to infiltrate into the soil, reducing surface runoff. The terrain on the project site, being characterized by gentle slopes formed by deposition of alluvium, has created natural braided drainage patterns where water spreads out and slows down, promoting infiltration.

Additionally, precipitation in the Soda Mountain area is sparse, with a monthly mean precipitation of less than 1 inch per month in the wettest months (typically December through February). Storm events that generate runoff tend to be short and intense, rather than prolonged; this typical episodic pattern occasionally produces flash flooding in the steeper terrain east and west of the project site during infrequent heavy storms, but this runoff then mostly dissipates and infiltrates in the flatter alluvium of the valley floor, where the project site is located.

2.2. Post-Project Conditions

The project proposes installation of NEXTracker Solar Arrays and construction of supporting infrastructure including a BESS, a substation, laydown yards, and roadways. The proposed NEXTracker solar technology has a very limited disturbance area; the panels track the sun and are mounted on footings, eliminating the need for grading.

Given the nature of the terrain, soils, vegetation, and precipitation patterns characterizing this project site, and the nature of the proposed project, it is best to design the drainage for the project focusing on conservation of the many existing natural braided drainage rills and shallow channels as they play a crucial role in the infiltration of stormwater runoff. As the proposed development area is at the intersection of the bajadas from the east and west (i.e., the valley floor), it is gently sloping, with drainage patterns being formed by the alluvial fans over millennia.

Hydraulic components to mitigate potential onsite impacts consist of berms and swales around the BESS and substation, and rock lining along susceptible features. Existing runoff upstream of the proposed substation and BESS on the north portion of the site will be collected in a swale and directed around the proposed project components. The swale will discharge at existing grade north of the BESS, where flow will spread out and infiltrate the existing soils.

3. HYDROLOGIC ANALYSIS

A prior drainage report for the project site was prepared by SWCA and reviewed by TRWE. We determined that, at the preliminary level, the SWCA analysis sufficiently characterizes the pre-



project drainage patterns for the entire site. Natural drainage rills and shallow channels were studied in the SWCA report for 2-year, 10-year, and 100-year design storm events; flow depths and velocities have been mapped for these design storms, and the results reflect the topography and historic aerial imagery, which have not changed in recent times. See **Attachment 3**.

To ensure adequate protection of the proposed facilities against the 100-year storm, TRWE computed the post-project 100-year peak flow in the area of the proposed BESS and substation using Advanced Engineering Software (AES). AES calculates runoff using the Rational Method and is based upon the criteria set forth in the San Bernadino County Hydrology Manual.

The remainder of the proposed site was analyzed and determined by TRWE to create no significant increase in runoff leaving the site due to the characteristic drainage patterns described above, including the high infiltration rate as a result of the flat slopes, shallow rills, short and sparse precipitation patterns, and Type A soils. Although there are components of the Soda Mountain Solar Project that have the potential to increase runoff (e.g., compacted roads and pads for some of the infrastructure, solar panels), almost all the precipitation running off of these features will infiltrate the soil layer beneath and surrounding them. This design approach of minimizing plant and soil disturbance, combined with the restoration and revegetation plan for temporarily disturbed areas, means no significant increase in runoff is expected to result from the proposed project components.

3.1. Peak Design Storm Calculations

For post-project conditions, the peak flow rate was calculated using the San Bernadino County Hydrology Manual Rational Method for a 100-year design storm. See results in **Attachment 2**.

Peak flow is equal to: $Q = CIA$

Where: Q = peak discharge (cfs)

C = runoff coefficient

I = average rainfall intensity, taken at the time of concentration (in/hr)

A = drainage area (ac)

And where C is equal to: $C = 0.90 ((a_i + (I - F_p)a_p)/I)$

* I = rainfall intensity, taken at the time of concentration (inches/hour)

* F_p = infiltration rate for pervious areas (inches/hour)



a_i = ratio of impervious area to total area (decimal fraction)

a_p = ratio of pervious area to total area (decimal fraction)

*Determined within AES in accordance with San Bernardino County Hydrology Manual

Table 1 | Summary of AES Inputs

Drainage Basin	Total Area (acres)	Percent Pervious	Soil Type
1	33.5	90	A

3.2. Peak Flow Summary

The post-project 100-year peak flow rate draining to the swale on the north portion of the site is shown in **Table 2** below.

Table 2 | 100-Year Peak Flow Rate

Drainage Basin	Area (acres)	100-Year Peak Flow (cfs)
1	33.5	67.1

This is graphically illustrated in the Hydrologic Work Map in **Attachment 2**.

4. HYDRAULIC ANALYSIS

The proposed swale at the north portion of the site is sized to ensure the 100-year peak flow of 67 cfs is contained with at least one (1) foot of freeboard from the top of the berm. The three (3) inch rock lining the swale and berm is appropriately sized to protect against the resulting velocities along the swale and berm. A typical section of the swale and berm is shown below.

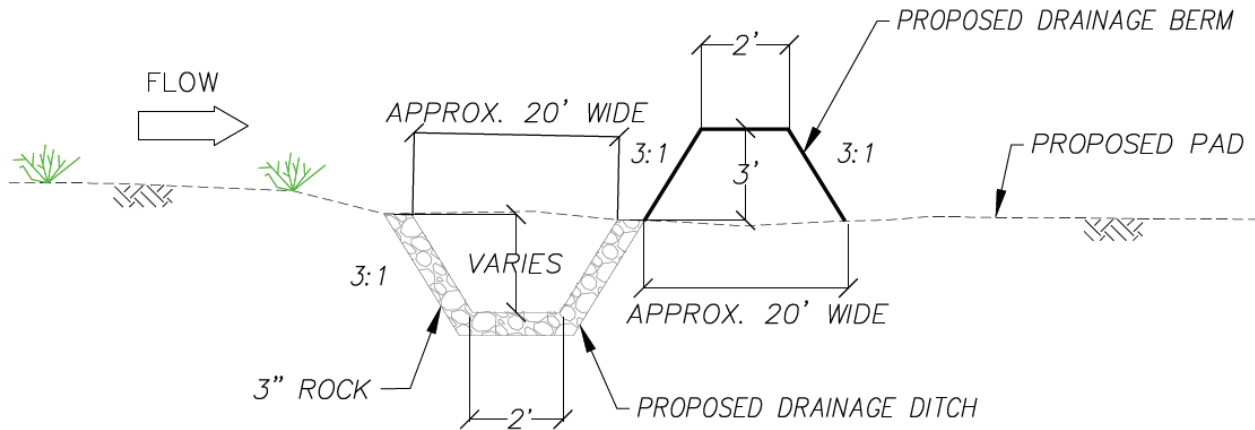

Figure 2 | Typical Berm and Swale Section

5. RESULTS AND CONCLUSIONS

Our preliminary analysis demonstrates the feasibility of concept for the onsite hydraulics within the proposed project. Analysis of the relevant impacts, including those outlined by CEQA, illustrates that the proposed drainage patterns provide the most feasible and low-impact solution for the project and do not alter the existing drainage pattern in a manner which would result in erosion or siltation, significantly increase the rate or amount of surface runoff, or impede or redirect flood flows.

Due to the highly pervious nature of the project site in both the existing and proposed conditions and limited disturbance areas, the surface runoff will not differ significantly in the proposed condition than in the existing. Increased runoff from the (disturbed and compacted) access roads will be dissipated and infiltrated onsite within the alluvial soils immediately downgradient of the roads, resulting in no significant increase in runoff or erosion. Where these access roads must cross shallow seasonal drainage paths, small diameter (e.g., 3-inch) rock may be used where needed to stabilize the road surface, as localized erosion/scour may otherwise occur in a major storm event. As the rock will be installed at existing grades, no disruption of grades leading to erosion/scour will occur.

Elevation and grading/compaction of pads is anticipated for the BESS yards, substation and switchyard. With that disturbance and grading/compaction, some concentration and increase of runoff and erosion is anticipated, absent mitigating countermeasures. These countermeasures



include small rock-lined swales and berms adjacent to the pads to capture and infiltrate increased runoff and minimizing erosion potential to a level of non-significance.

The vast majority of solar panel pilings will not require any protection, but where needed, and as determined during the final design of the project, some pilings will be deeper to counter any potential localized scour that the pilings may be subject to. In no case would the pilings be subject to scour exceeding 2 feet however, and any scour would be very localized and contained. If needed, small rock may be used as a mitigating countermeasure to prevent the localized scour.

6. REFERENCES

1. San Bernadino County, 1986 Hydrology Manual



Drainage Report
Soda Mountain Solar Project
March 2026

ATTACHMENT 1

Soils Map

Legend

 Site Boundary

Soil Type

 A

 B

 C

 D

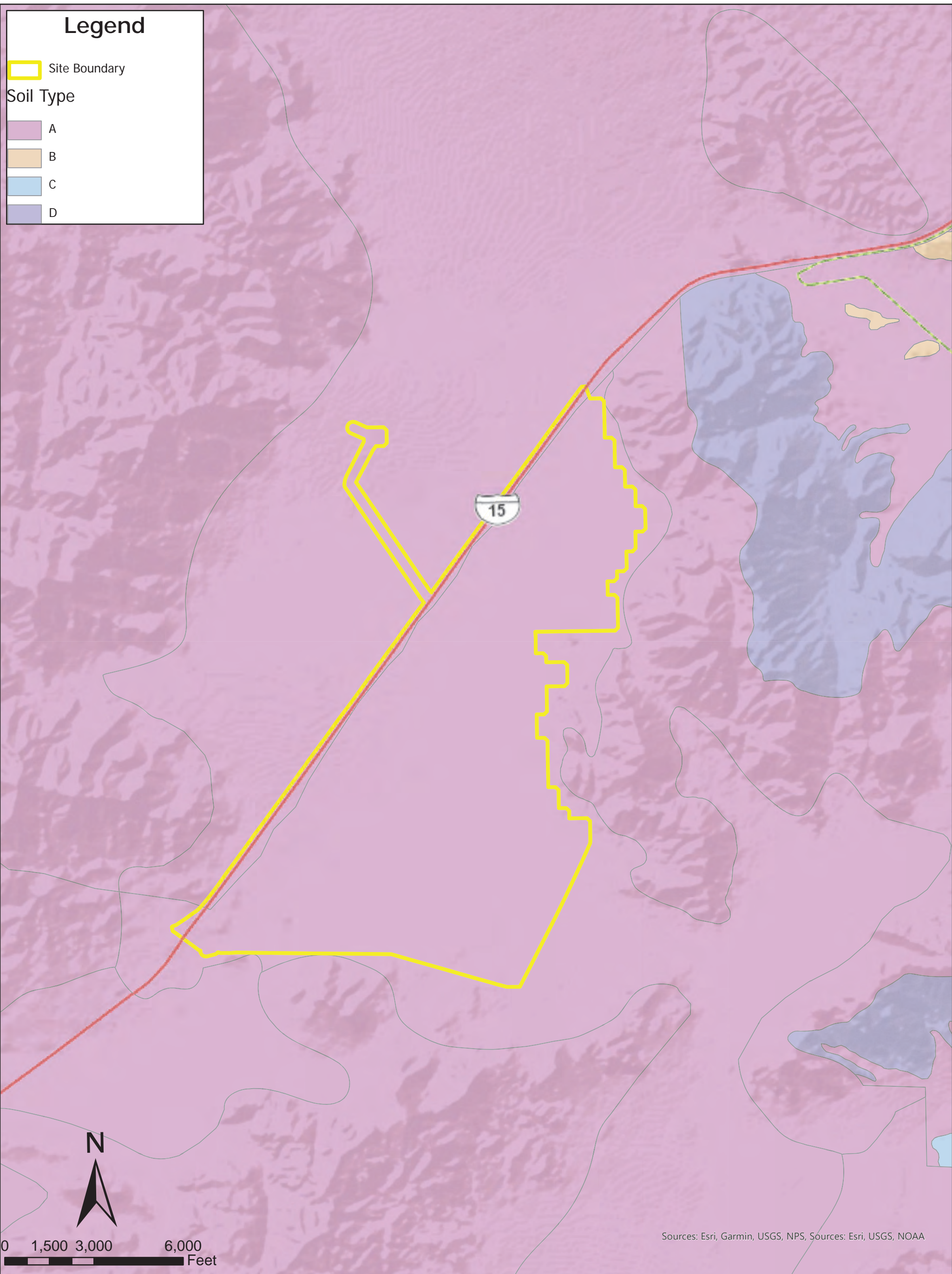

Sources: Esri, Garmin, USGS, NPS, Sources: Esri, USGS, NOAA



TORY R. WALKER
ENGINEERING
122 Civic Center Drive, Suite 206 Vista, CA 92084

Soda Mountain Solar Project
Soil Map
February 2026



Drainage Report
Soda Mountain Solar Project
March 2026

ATTACHMENT 2

Rational Method Calculations



Drainage Report
Soda Mountain Solar Project
March 2026

Hydrologic Work Map

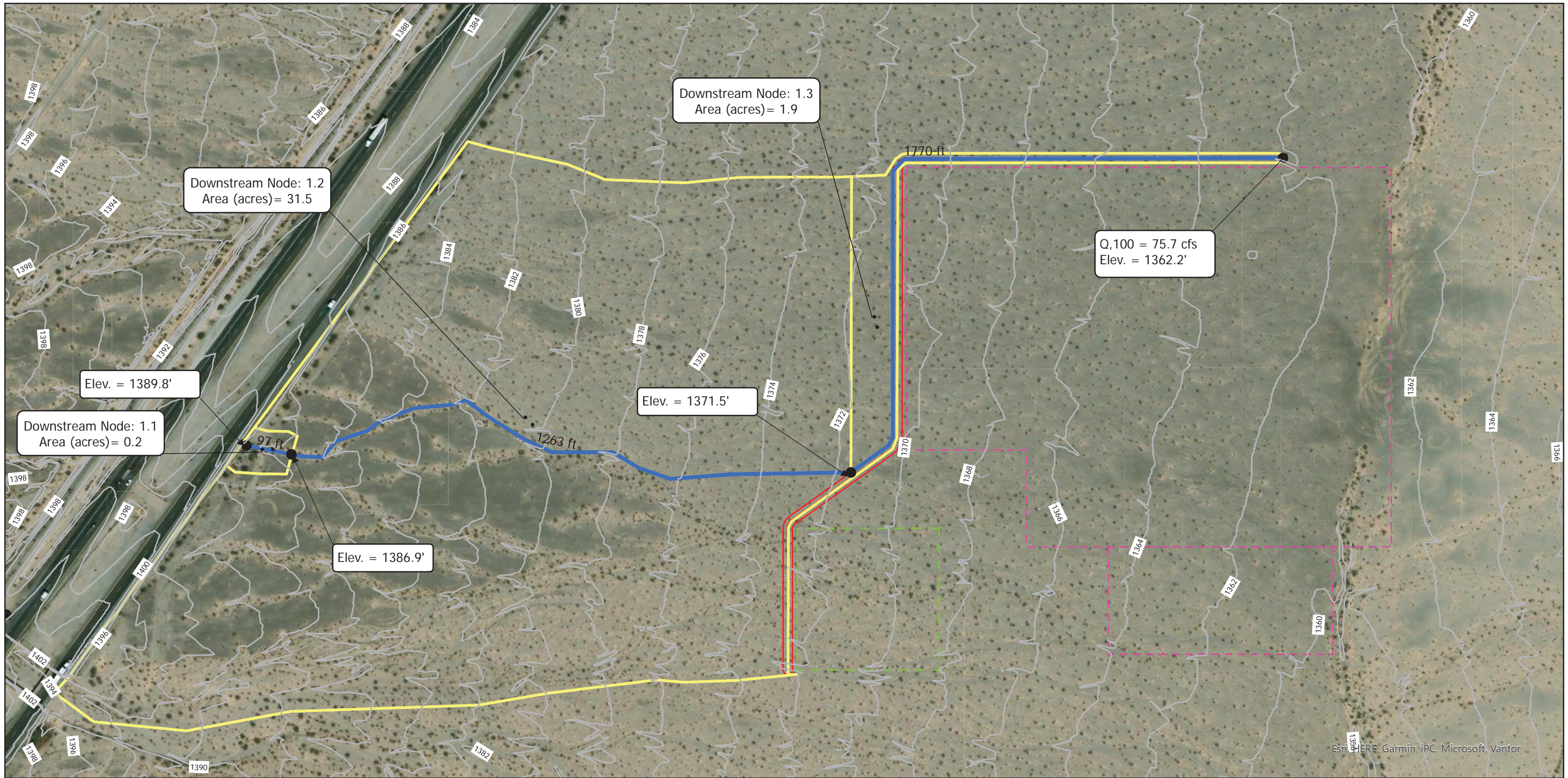

TORY R. WALKER
ENGINEERING
122 Civic Center Drive, Suite 206 Vista, CA 92084

Legend

- Flow Path
- Proposed Berm
- - - Proposed BESS
- - - Proposed Substation
- ▭ Drainage Boundary



0 100 200 400 Feet

Soda Mountain Solar Project
Hydrologic Work Map
February 2026



Drainage Report
Soda Mountain Solar Project
March 2026

NOAA Atlas 14 Rainfall Intensity



NOAA Atlas 14, Volume 6, Version 2
 Location name: Barstow, California, USA*
 Latitude: 34.7977°, Longitude: -117.1034°
 Elevation: 2642 ft**
 * source: ESRI Maps
 ** source: USGS



POINT PRECIPITATION FREQUENCY ESTIMATES

Sanja Perica, Sarah Dietz, Sarah Heim, Lillian Hiner, Kazungu Maitaria, Deborah Martin, Sandra Pavlovic, Ishani Roy, Carl Trypaluk, Dale Unruh, Fenglin Yan, Michael Yekta, Tan Zhao, Geoffrey Bonnin, Daniel Brewer, Li-Chuan Chen, Tye Parzybok, John Yarchoan

NOAA, National Weather Service, Silver Spring, Maryland

[PF_tabular](#) | [PF_graphical](#) | [Maps & aeriels](#)

PF tabular

PDS-based point precipitation frequency estimates with 90% confidence intervals (in inches/hour)¹										
Duration	Average recurrence interval (years)									
	1	2	5	10	25	50	100	200	500	1000
5-min	0.996 (0.816-1.22)	1.39 (1.14-1.72)	1.93 (1.58-2.39)	2.40 (1.96-3.00)	3.08 (2.42-3.96)	3.62 (2.80-4.76)	4.21 (3.17-5.65)	4.84 (3.54-6.67)	5.74 (4.03-8.24)	6.48 (4.42-9.62)
10-min	0.714 (0.582-0.876)	0.996 (0.816-1.22)	1.39 (1.13-1.72)	1.72 (1.40-2.15)	2.21 (1.73-2.84)	2.60 (2.00-3.41)	3.02 (2.27-4.05)	3.47 (2.54-4.79)	4.12 (2.89-5.91)	4.64 (3.16-6.90)
15-min	0.572 (0.472-0.704)	0.804 (0.656-0.988)	1.12 (0.916-1.38)	1.39 (1.13-1.73)	1.78 (1.40-2.29)	2.10 (1.61-2.75)	2.43 (1.83-3.27)	2.80 (2.05-3.86)	3.32 (2.33-4.76)	3.75 (2.55-5.56)
30-min	0.402 (0.330-0.494)	0.562 (0.460-0.692)	0.784 (0.640-0.968)	0.972 (0.788-1.21)	1.25 (0.978-1.60)	1.47 (1.13-1.92)	1.70 (1.28-2.29)	1.96 (1.43-2.70)	2.32 (1.63-3.33)	2.62 (1.78-3.89)
60-min	0.270 (0.222-0.333)	0.378 (0.310-0.466)	0.527 (0.431-0.652)	0.655 (0.531-0.816)	0.838 (0.658-1.08)	0.987 (0.760-1.30)	1.15 (0.862-1.54)	1.32 (0.964-1.82)	1.56 (1.10-2.24)	1.76 (1.20-2.62)
2-hr	0.184 (0.151-0.226)	0.249 (0.204-0.307)	0.339 (0.277-0.419)	0.415 (0.337-0.517)	0.524 (0.411-0.674)	0.611 (0.470-0.802)	0.703 (0.528-0.944)	0.802 (0.587-1.11)	0.942 (0.662-1.35)	1.06 (0.718-1.57)
3-hr	0.145 (0.119-0.179)	0.195 (0.160-0.240)	0.263 (0.215-0.325)	0.321 (0.260-0.399)	0.402 (0.316-0.517)	0.467 (0.359-0.613)	0.536 (0.403-0.720)	0.609 (0.445-0.840)	0.712 (0.501-1.02)	0.796 (0.541-1.18)
6-hr	0.093 (0.076-0.115)	0.125 (0.102-0.154)	0.167 (0.137-0.207)	0.203 (0.165-0.253)	0.254 (0.199-0.326)	0.293 (0.226-0.385)	0.335 (0.252-0.450)	0.379 (0.278-0.524)	0.441 (0.310-0.634)	0.491 (0.334-0.730)
12-hr	0.056 (0.046-0.069)	0.075 (0.062-0.093)	0.102 (0.083-0.126)	0.124 (0.100-0.154)	0.154 (0.121-0.198)	0.178 (0.137-0.234)	0.203 (0.153-0.273)	0.230 (0.168-0.318)	0.267 (0.188-0.384)	0.297 (0.202-0.441)
24-hr	0.036 (0.032-0.041)	0.049 (0.043-0.056)	0.066 (0.059-0.077)	0.081 (0.071-0.094)	0.101 (0.086-0.122)	0.117 (0.097-0.144)	0.133 (0.108-0.168)	0.150 (0.118-0.195)	0.174 (0.131-0.235)	0.193 (0.141-0.270)
2-day	0.021 (0.018-0.024)	0.029 (0.025-0.033)	0.039 (0.034-0.045)	0.048 (0.042-0.055)	0.059 (0.050-0.072)	0.068 (0.057-0.084)	0.078 (0.063-0.098)	0.088 (0.069-0.114)	0.101 (0.076-0.137)	0.112 (0.082-0.157)
3-day	0.015 (0.013-0.017)	0.021 (0.018-0.024)	0.028 (0.025-0.033)	0.034 (0.030-0.040)	0.043 (0.036-0.052)	0.049 (0.041-0.061)	0.056 (0.045-0.071)	0.063 (0.050-0.082)	0.073 (0.055-0.098)	0.080 (0.058-0.112)
4-day	0.012 (0.010-0.013)	0.016 (0.014-0.019)	0.022 (0.020-0.026)	0.027 (0.024-0.032)	0.034 (0.028-0.041)	0.039 (0.032-0.048)	0.044 (0.035-0.055)	0.049 (0.039-0.064)	0.057 (0.043-0.077)	0.062 (0.045-0.087)
7-day	0.007 (0.006-0.008)	0.010 (0.009-0.011)	0.013 (0.012-0.016)	0.016 (0.014-0.019)	0.020 (0.017-0.024)	0.023 (0.019-0.029)	0.026 (0.021-0.033)	0.029 (0.023-0.038)	0.034 (0.025-0.046)	0.037 (0.027-0.052)
10-day	0.005 (0.005-0.006)	0.007 (0.006-0.008)	0.010 (0.009-0.011)	0.012 (0.010-0.014)	0.015 (0.012-0.018)	0.017 (0.014-0.021)	0.019 (0.015-0.024)	0.021 (0.017-0.027)	0.024 (0.018-0.033)	0.026 (0.019-0.037)
20-day	0.003 (0.002-0.003)	0.004 (0.004-0.005)	0.006 (0.005-0.006)	0.007 (0.006-0.008)	0.008 (0.007-0.010)	0.009 (0.008-0.012)	0.011 (0.009-0.014)	0.012 (0.009-0.016)	0.014 (0.010-0.018)	0.015 (0.011-0.021)
30-day	0.002 (0.002-0.002)	0.003 (0.003-0.003)	0.004 (0.004-0.005)	0.005 (0.004-0.006)	0.006 (0.005-0.008)	0.007 (0.006-0.009)	0.008 (0.006-0.010)	0.009 (0.007-0.012)	0.010 (0.008-0.014)	0.011 (0.008-0.016)
45-day	0.001 (0.001-0.002)	0.002 (0.002-0.003)	0.003 (0.003-0.004)	0.004 (0.003-0.005)	0.005 (0.004-0.006)	0.005 (0.004-0.007)	0.006 (0.005-0.008)	0.007 (0.005-0.009)	0.008 (0.006-0.011)	0.009 (0.006-0.012)
60-day	0.001 (0.001-0.001)	0.002 (0.001-0.002)	0.002 (0.002-0.003)	0.003 (0.003-0.004)	0.004 (0.003-0.005)	0.004 (0.004-0.006)	0.005 (0.004-0.006)	0.006 (0.004-0.008)	0.007 (0.005-0.009)	0.007 (0.005-0.010)

¹ Precipitation frequency (PF) estimates in this table are based on frequency analysis of partial duration series (PDS). Numbers in parenthesis are PF estimates at lower and upper bounds of the 90% confidence interval. The probability that precipitation frequency estimates (for a given duration and average recurrence interval) will be greater than the upper bound (or less than the lower bound) is 5%. Estimates at upper bounds are not checked against probable maximum precipitation (PMP) estimates and may be higher than currently valid PMP values. Please refer to NOAA Atlas 14 document for more information.

[Back to Top](#)

PF graphical

PDS-based intensity-duration-frequency (IDF) curves

Latitude: 34.7977°, Longitude: -117.1034°

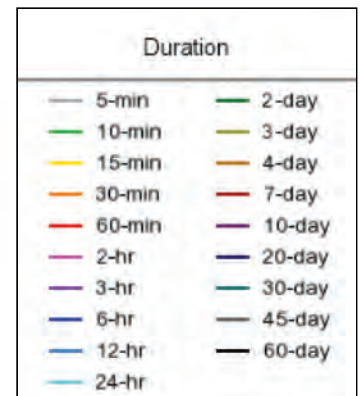
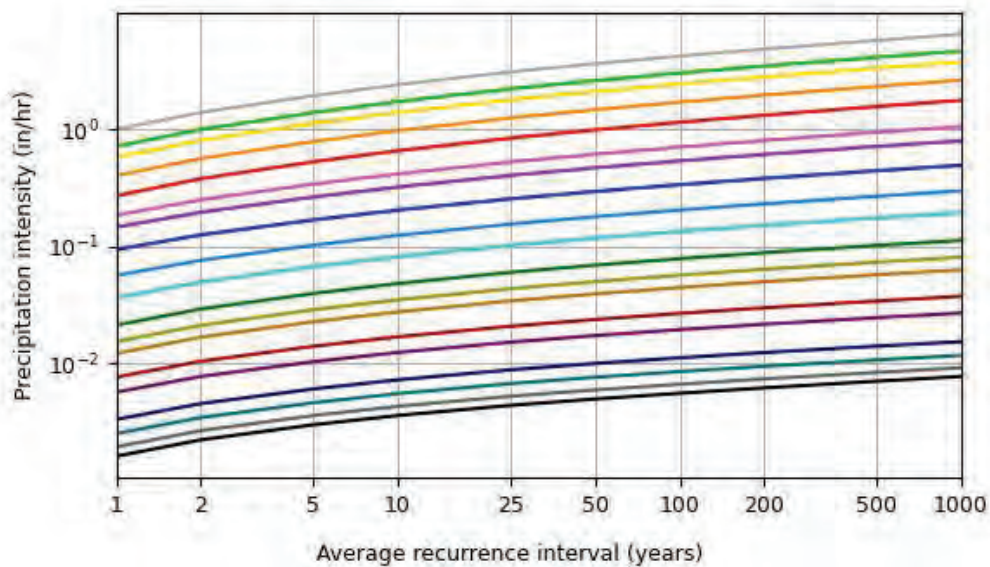
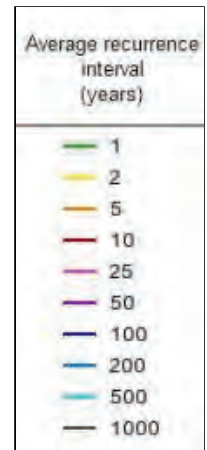
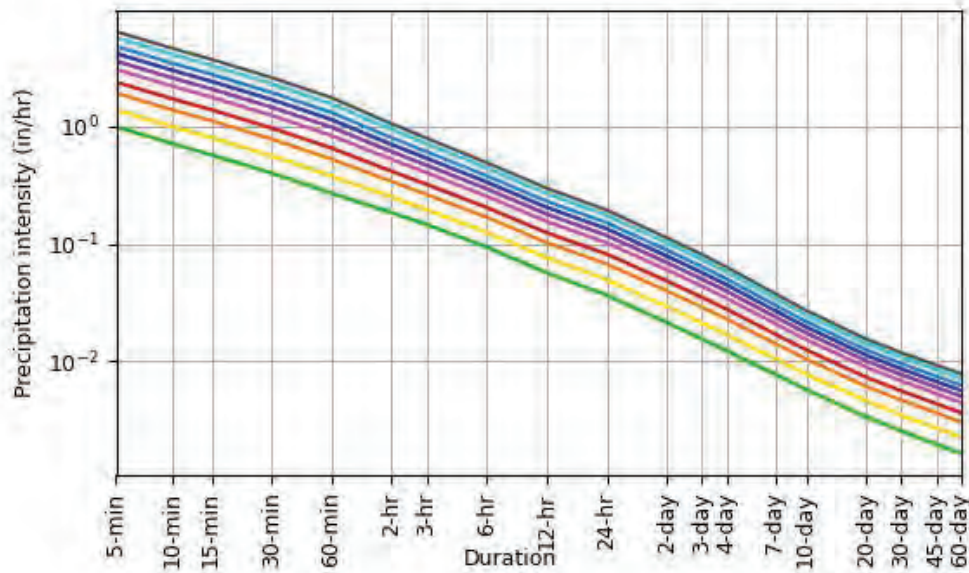

[Back to Top](#)

Maps & aerials

Small scale terrain

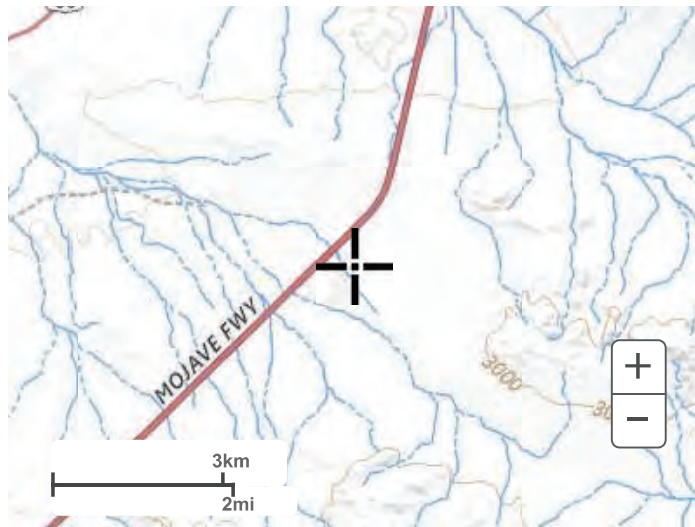

Large scale terrain



Large scale map

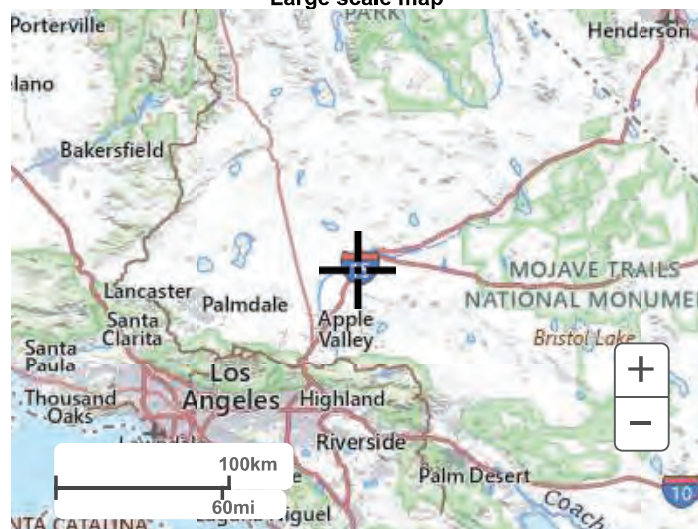

Large scale aerial



[Back to Top](#)

[US Department of Commerce](#)
[National Oceanic and Atmospheric Administration](#)
[National Weather Service](#)
[National Water Center](#)
1325 East West Highway
Silver Spring, MD 20910
Questions?: HDSC.Questions@noaa.gov

[Disclaimer](#)



Drainage Report
Soda Mountain Solar Project
March 2026

Post-Project AES Output

RATIONAL METHOD HYDROLOGY COMPUTER PROGRAM PACKAGE

(Reference: 1986 SAN BERNARDINO CO. HYDROLOGY CRITERION)

(c) Copyright 1983-2016 Advanced Engineering Software (aes)

Ver. 23.0 Release Date: 07/01/2016 License ID 1532

Analysis prepared by: Tory R. Walker Engineering

FILE NAME: SODA.DAT

TIME/DATE OF STUDY: 16:13 03/09/2026

=====

USER SPECIFIED HYDROLOGY AND HYDRAULIC MODEL INFORMATION:

=====

--*TIME-OF-CONCENTRATION MODEL*--

USER SPECIFIED STORM EVENT(YEAR) = 100.00

SPECIFIED MINIMUM PIPE SIZE(INCH) = 3.00

SPECIFIED PERCENT OF GRADIENTS(DECIMAL) TO USE FOR FRICTION SLOPE = 0.95

USER-DEFINED TABLED RAINFALL USED

NUMBER OF [TIME,INTENSITY] DATA PAIRS = 10

- 1) 5.00; 4.210
- 2) 10.00; 3.020
- 3) 15.00; 2.430
- 4) 30.00; 1.700
- 5) 60.00; 1.150
- 6) 120.00; 0.703
- 7) 180.00; 0.536
- 8) 360.00; 0.335

9) 720.00; 0.203

10) 1200.00; 0.120

ANTECEDENT MOISTURE CONDITION (AMC) III ASSUMED FOR RATIONAL METHOD

USER-DEFINED STREET-SECTIONS FOR COUPLED PIPEFLOW AND STREETFLOW MODEL

HALF- CROWN TO STREET-CROSSFALL: CURB GUTTER-GEOMETRIES: MANNING

WIDTH CROSSFALL IN- / OUT-/PARK- HEIGHT WIDTH LIP HIKE FACTOR

NO. (FT) (FT) SIDE / SIDE/ WAY (FT) (FT) (FT) (FT) (n)

==== =====

1 30.0 20.0 0.018/0.018/0.020 0.67 2.00 0.0312 0.167 0.0150

GLOBAL STREET FLOW-DEPTH CONSTRAINTS:

1. Relative Flow-Depth = 0.00 FEET

as (Maximum Allowable Street Flow Depth) - (Top-of-Curb)

2. (Depth)*(Velocity) Constraint = 6.0 (FT*FT/S)

*PIPE MAY BE SIZED TO HAVE A FLOW CAPACITY LESS THAN

UPSTREAM TRIBUTARY PIPE.*

*USER-SPECIFIED MINIMUM TOPOGRAPHIC SLOPE ADJUSTMENT NOT SELECTED

FLOW PROCESS FROM NODE 1.00 TO NODE 1.10 IS CODE = 21

>>>>RATIONAL METHOD INITIAL SUBAREA ANALYSIS<<<<<

>>USE TIME-OF-CONCENTRATION NOMOGRAPH FOR INITIAL SUBAREA<<

=====

INITIAL SUBAREA FLOW-LENGTH(FEET) = 97.00

ELEVATION DATA: UPSTREAM(FEET) = 1389.80 DOWNSTREAM(FEET) = 1386.88

Tc = K*[(LENGTH** 3.00)/(ELEVATION CHANGE)]**0.20

SUBAREA ANALYSIS USED MINIMUM Tc(MIN.) = 6.117

* 100 YEAR RAINFALL INTENSITY(INCH/HR) = 3.944

SUBAREA Tc AND LOSS RATE DATA(AMC III):

DEVELOPMENT TYPE/ LAND USE	SCS SOIL GROUP	AREA (ACRES)	Fp (INCH/HR)	Ap (DECIMAL)	SCS CN	Tc (MIN.)
-------------------------------	-------------------	-----------------	-----------------	-----------------	-----------	--------------

RESIDENTIAL

"4 DWELLING/ACRE"	A	0.24	0.74	0.900	52	6.12
-------------------	---	------	------	-------	----	------

SUBAREA AVERAGE PERVIOUS LOSS RATE, Fp(INCH/HR) = 0.74

SUBAREA AVERAGE PERVIOUS AREA FRACTION, Ap = 0.900

SUBAREA RUNOFF(CFS) = 0.71

TOTAL AREA(ACRES) = 0.24 PEAK FLOW RATE(CFS) = 0.71

FLOW PROCESS FROM NODE 1.10 TO NODE 1.20 IS CODE = 51

>>>>COMPUTE TRAPEZOIDAL CHANNEL FLOW<<<<<

>>>>TRAVELTIME THRU SUBAREA (EXISTING ELEMENT)<<<<<

=====

ELEVATION DATA: UPSTREAM(FEET) = 1386.88 DOWNSTREAM(FEET) = 1371.47

CHANNEL LENGTH THRU SUBAREA(FEET) = 1263.00 CHANNEL SLOPE = 0.0122

CHANNEL BASE(FEET) = 3.50 "Z" FACTOR = 5.000

MANNING'S FACTOR = 0.020 MAXIMUM DEPTH(FEET) = 5.00

* 100 YEAR RAINFALL INTENSITY(INCH/HR) = 3.018

SUBAREA LOSS RATE DATA(AMC III):

DEVELOPMENT TYPE/ LAND USE	SCS SOIL GROUP	AREA (ACRES)	Fp (INCH/HR)	Ap (DECIMAL)	SCS CN
-------------------------------	-------------------	-----------------	-----------------	-----------------	-----------

RESIDENTIAL

"4 DWELLING/ACRE"	A	31.50	0.74	0.900	52
-------------------	---	-------	------	-------	----

SUBAREA AVERAGE PERVIOUS LOSS RATE, Fp(INCH/HR) = 0.74

SUBAREA AVERAGE PERVIOUS AREA FRACTION, $A_p = 0.900$

TRAVEL TIME COMPUTED USING ESTIMATED FLOW(CFS) = 35.03

TRAVEL TIME THRU SUBAREA BASED ON VELOCITY(FEET/SEC.) = 5.40

AVERAGE FLOW DEPTH(FEET) = 0.84 TRAVEL TIME(MIN.) = 3.90

T_c (MIN.) = 10.02

SUBAREA AREA(ACRES) = 31.50 SUBAREA RUNOFF(CFS) = 66.62

EFFECTIVE AREA(ACRES) = 31.74 AREA-AVERAGED F_m (INCH/HR) = 0.67

AREA-AVERAGED F_p (INCH/HR) = 0.74 AREA-AVERAGED $A_p = 0.90$

TOTAL AREA(ACRES) = 31.7 PEAK FLOW RATE(CFS) = 67.13

END OF SUBAREA CHANNEL FLOW HYDRAULICS:

DEPTH(FEET) = 1.14 FLOW VELOCITY(FEET/SEC.) = 6.40

LONGEST FLOWPATH FROM NODE 1.00 TO NODE 1.20 = 1360.00 FEET.

FLOW PROCESS FROM NODE 1.20 TO NODE 1.30 IS CODE = 51

>>>>COMPUTE TRAPEZOIDAL CHANNEL FLOW<<<<<

>>>>TRAVELTIME THRU SUBAREA (EXISTING ELEMENT)<<<<<

=====

ELEVATION DATA: UPSTREAM(FEET) = 1371.50 DOWNSTREAM(FEET) = 1362.20

CHANNEL LENGTH THRU SUBAREA(FEET) = 1518.00 CHANNEL SLOPE = 0.0061

CHANNEL BASE(FEET) = 2.00 "Z" FACTOR = 3.000

MANNING'S FACTOR = 0.020 MAXIMUM DEPTH(FEET) = 3.00

* 100 YEAR RAINFALL INTENSITY(INCH/HR) = 2.486

SUBAREA LOSS RATE DATA(AMC III):

DEVELOPMENT TYPE/ SCS SOIL AREA F_p A_p SCS

LAND USE GROUP (ACRES) (INCH/HR) (DECIMAL) CN

RESIDENTIAL

".4 DWELLING/ACRE" A 1.80 0.74 0.900 52

SUBAREA AVERAGE PERVIOUS LOSS RATE, F_p (INCH/HR) = 0.74

SUBAREA AVERAGE PERVIOUS AREA FRACTION, A_p = 0.900

TRAVEL TIME COMPUTED USING ESTIMATED FLOW(CFS) = 68.61

TRAVEL TIME THRU SUBAREA BASED ON VELOCITY(FEET/SEC.) = 5.62

AVERAGE FLOW DEPTH(FEET) = 1.71 TRAVEL TIME(MIN.) = 4.50

T_c (MIN.) = 14.52

SUBAREA AREA(ACRES) = 1.80 SUBAREA RUNOFF(CFS) = 2.95

EFFECTIVE AREA(ACRES) = 33.54 AREA-AVERAGED F_m (INCH/HR) = 0.67

AREA-AVERAGED F_p (INCH/HR) = 0.74 AREA-AVERAGED A_p = 0.90

TOTAL AREA(ACRES) = 33.5 PEAK FLOW RATE(CFS) = 67.13

NOTE: PEAK FLOW RATE DEFAULTED TO UPSTREAM VALUE

END OF SUBAREA CHANNEL FLOW HYDRAULICS:

DEPTH(FEET) = 1.70 FLOW VELOCITY(FEET/SEC.) = 5.58

LONGEST FLOWPATH FROM NODE 1.00 TO NODE 1.30 = 2878.00 FEET.

=====

END OF STUDY SUMMARY:

TOTAL AREA(ACRES) = 33.5 T_c (MIN.) = 14.52

EFFECTIVE AREA(ACRES) = 33.54 AREA-AVERAGED F_m (INCH/HR) = 0.67

AREA-AVERAGED F_p (INCH/HR) = 0.74 AREA-AVERAGED A_p = 0.900

PEAK FLOW RATE(CFS) = 67.13

=====

=====

END OF RATIONAL METHOD ANALYSIS



Drainage Report
Soda Mountain Solar Project
March 2026

ATTACHMENT 3
SWCA Drainage Report

DOCKETED	
Docket Number:	24-OPT-03
Project Title:	Soda Mountain Solar
TN #:	257946
Document Title:	Appendix K Stormwater Drainage Report
Description:	In this Appendix, hydrologic conditions were analyzed to understand the existing and future flood hazards for the proposed Project site; determine inundation areas and spatial distribution of stormwater depths and velocities for the 2-year, 10-year, and 100-year 24-hour storm events; and identify any flood hazard areas within the site.
Filer:	Hannah Gbeh
Organization:	Resolution Environmental
Submitter Role:	Applicant Consultant
Submission Date:	7/22/2024 5:19:38 PM
Docketed Date:	7/23/2024



Soda Mountain Solar Project
Stormwater Drainage Report
San Bernardino County, California

JUNE 2024

PREPARED FOR

Soda Mountain Solar, LLC

PREPARED BY

SWCA Environmental Consultants

SODA MOUNTAIN SOLAR PROJECT STORMWATER DRAINAGE REPORT SAN BERNARDINO, CALIFORNIA

Prepared for

Soda Mountain Solar, LLC
604 Sutter Street, Suite 250
Folsom, California 95630
Attn: Ziad Alaywan, P.E.

Prepared by

Ben Snyder, M.S., P.E.

SWCA Environmental Consultants
320 North Halstead Street, Suite 120
Pasadena, California 91107
(626) 240-0587
www.swca.com

SWCA Project No. 68347

June 2024

CONTENTS

1	Background and Objectives.....	1
2	Calculation Methodologies	1
2.1	Topographic Data	1
2.2	Rainfall Data.....	2
2.3	Soils and Land Cover Data.....	3
2.4	Floodplain Data	3
3	Model Results.....	4
4	Literature Cited.....	9

Appendices

APPENDIX A	Miscellaneous Site Data
APPENDIX B	Rainfall Data
APPENDIX C	Soils and Land Cover Data
APPENDIX D	HEC-RAS Model Results

Figures

Figure 1:	Monthly Mean Precipitation at NWS Baker Station	2
Figure 2:	Overview of project site showing locations of hydrograph output locations and drainage divide.	5
Figure 3:	2-year hydrograph of flow exiting the site to the south, proposed condition showing a significant increase and change in timing in stormwater runoff compared to existing condition.	6
Figure 4:	2-year hydrograph of flow existing to the north of the site, proposed condition showing a small decrease in peak flow.	6
Figure 5:	10-year hydrograph of flow exiting the site to the south, showing no change in peak stormwater runoff among existing and proposed conditions.	7
Figure 6:	10-year hydrograph of flow exiting the site to the north, showing no change in peak stormwater runoff among existing and proposed conditions.	8
Figure 7:	100-year hydrograph of flow exiting the site to the south, proposed condition showing decrease in peak stormwater runoff compared to existing condition.....	8
Figure 8:	100-year hydrograph of flow exiting the site to the north, showing no significant change in stormwater runoff.	9

Tables

Table 1:	Hydrologic Soil Groups	3
----------	------------------------------	---

This page intentionally left blank.

1 BACKGROUND AND OBJECTIVES

Soda Mountain Solar, LLC, is proposing a solar power production facility in the Soda Mountain area of San Bernardino County, California, and is currently seeking an Incidental Take Permit and Streambed Alteration Agreement from the California Department of Fish and Wildlife, along with a Title 27 Discharge Permit and Clean Water Act Section 401 Permit from the Lahontan Regional Water Quality Control Board. In support of those permit applications, SWCA Environmental Consultants (SWCA) conducted a stormwater drainage analysis.

Hydrologic conditions were analyzed to understand the existing and future flood hazards for the proposed Soda Mountain Solar Project (project) site; determine inundation areas and spatial distribution of stormwater depths and velocities for the 2-year, 10-year, and 100-year 24-hour storm events; and identify any flood hazard areas within the site. The project site is located on federal land managed by Bureau of Land Management. It is approximately 2,670 acres and is located 3.83 miles northwest of Zzyzx, California, and 6 miles southwest of Baker, California, along Interstate 15. The study area contains numerous alluvial fans that drain toward the proposed site. The site is located in Federal Emergency Management Agency (FEMA) Zone D, meaning that the area has not been studied using detailed methods and existing flood risk is unknown (Appendix A).

2 CALCULATION METHODOLOGIES

A 2-dimensional (2-D) rain-on-grid hydrodynamic model was prepared for this study area using HEC-RAS v. 6.3.1, developed by the U.S. Army Corps of Engineers, Hydrologic Engineering Center. The program is capable of modeling rainfall-runoff and surface water hydraulics. For this study, the area of interest (AOI) modeled in HEC-RAS included the site of proposed solar facility and the contributing drainage area. Existing and proposed conditions were modeled to understand the effect of the proposed solar development on stormwater drainage. The proposed conditions were based on 30% civil design plans dated August 8, 2023, and provided by QCells and Kleinfelder, Inc. The 30% civil design plans that are incorporated into the proposed conditions are the berm outlines, drainage channels, catchment basins, and solar panels. The proposed land cover layer within the model was adjusted to delineate the proposed design features and represent the impervious conditions of the solar array coverage. However, the proposed condition in the model did not include the 12 box culverts and eight low-water crossings due to the assumptions that the culverts will be designed to allow the channels to withstand the flow capacity. The following section describes the available data used and assumptions made by SWCA to develop the model.

2.1 Topographic Data

Existing terrain conditions were based on a digital elevation model (DEM) with 1-meter resolution from the U.S. Geological Survey (USGS) merged with the detailed topographic survey data of the site provided by Michael Baker, Inc. The DEM was reprojected to North American Datum of 1983 (NAD 83) California Zone 5, converted to units of U.S. survey feet, and imported to the HEC-RAS to build the topographic surface for the existing condition model. A rectilinear mesh was created for the AOI using 100-foot grid cells. The mesh was refined by adding additional computation points within the known areas of concentrated flow, creating a mesh of 50-foot grid cells within these areas. The proposed terrain was created by modifying the existing conditions DEM to represent conditions shown in the 30% civil design, which included multiple berms, channels, and sediment basins.

2.2 Rainfall Data

A hyetograph was developed based on the Soil Conservation Service (SCS) dimensionless curve and Type II rainfall data derived from National Oceanic and Atmospheric Administration (NOAA) Atlas 14 precipitation data for the 2-year, 10-year, and 100-year 24-hour storm events over the Soda Mountain location coordinates 35.1575 degrees North, 116.1821 degrees West, near Baker, California.

The hyetograph illustrates the intensity of rainfall over time; the horizontal axis of the hyetograph represents time, while the vertical axis represents rainfall depth. Each storm event was run as an individual unsteady flow model with a precipitation value added to the meteorological data encompassing the entire AOI and normal depth downstream conditions with friction slopes measured from the topographic data in HEC-RAS. The hyetographs are provided in Appendix B.

Meantime, a monthly mean precipitation summary was obtained from the National Weather Service (NWS) past weather record (NWS, 2024). Precipitation at NWS Baker Station from 1996 – 2013 was used for analysis the pattern of the monthly precipitation because Baker Station is close to the project site. The monthly mean precipitation is shown in Figure 1 below. Precipitation information from California Irrigation Management Information System (CIMIS) was used for comparison. The three closest CIMIS stations 117-Victorville, 221-Cadiz Valley, and 257-Ridgecrest shows similar precipitation patterns as the NWS Baker Station precipitation data. The CIMIS stations are further away compared to the NWS Baker Station so the CIMIS stations information are not included in this report. The construction and operation of project is not anticipated to alter the monthly precipitation patterns.

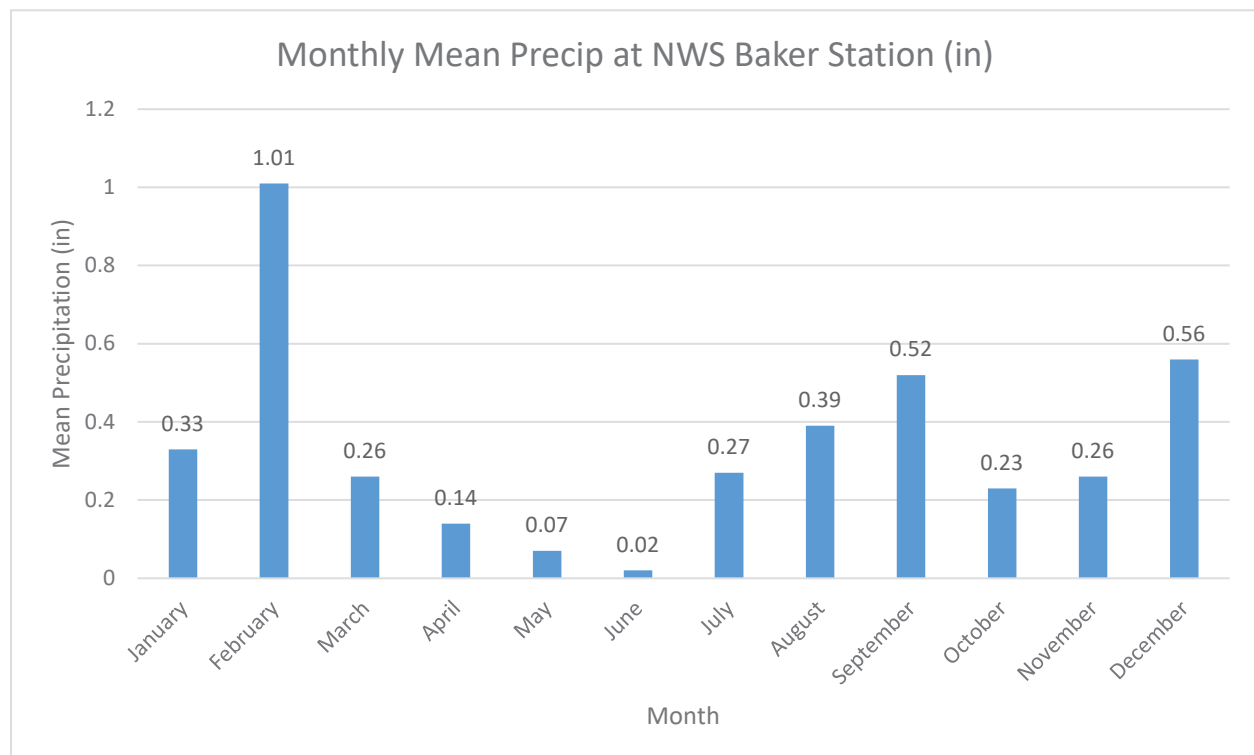

Figure 1: Monthly Mean Precipitation at NWS Baker Station

2.3 Soils and Land Cover Data

The study area soil types consist of gravel with silt and sand. Therefore, the hydrologic soil groups (HSGs) were determined to be A, B, and C for this site based on information from the soil watershed study and the Jurisdictional Determination Report by the URS Land Management Consulting Group (2009) and the Natural Resource Conservation Service (NRCS). See Appendix C and Table 1 below for descriptions of individual HSGs. Group D soils were not present based on the NRCS soil survey information.

Table 1. Hydrologic Soil Groups

HSG	Description
Group A	Sand, loamy sand or sandy loam types of soils. These soils have low runoff potential and high infiltration rates even when thoroughly wetted. They consist chiefly of deep, well-drained to excessively drained sands or gravels and have a high rate of water transmission.
Group B	Silt loam or loam. Soils in this HSG have a moderate infiltration rate when thoroughly wetted and consist chiefly of moderately deep to deep, moderately well-drained to well-drained soils with moderately fine to moderately coarse textures.
Group C	Sandy clay loam. These soils have low infiltration rates when thoroughly wetted and consist chiefly of soils with a layer that impedes downward movement of water and soils with moderately fine to fine structure.
Group D	Clay loam, silty clay loam, sandy clay, silty clay or clay. This HSG has the highest runoff potential. These soils have very low infiltration rates when thoroughly wetted and consist chiefly of clay soils with a high swelling potential, soils with a permanent high-water table, soils with a claypan or clay layer at or near the surface and shallow soils over nearly impervious material.

A 30-meter land cover raster was retrieved from the National Land Cover Database (Multi-Resolution Land Characteristics Consortium 2019).

The land cover and soils data were reprojected to NAD 83 California Zone 5, converted to units of U.S. survey feet, and imported to HEC-RAS to build the existing condition model. The infiltration dataset was created in HEC-RAS using a parametrization of the soils and land cover layers. Manning’s n roughness values were assigned based on land cover conditions. The existing land cover condition at the site is predominantly classified “Shrub-Scrub”. Areas of proposed solar areas were assumed to be converted to “Developed, Medium Intensity,” with increased SCS curve numbers and impervious areas to account for site development. See Appendix C for further information.

2.4 Floodplain Data

According to the FEMA, the area in which the project site is located is classified as Zone D, which indicates possible but undetermined flood hazards. The flood insurance study and map for the Soda Mountain San Bernardino County, California, incorporated areas by FEMA were used to determine the extent of the zone and the regulations within the zone (FEMA 2023). The coordinate points used to generate the Soda Mountain flood insurance rate map project site were 35.1575 degrees North, 116.1821 degrees West. Based on Best Available Map (BAM) provided by California Department of Water Resources indicated the location of the project site is not within the floodplain (BAM 2024). SWCA obtained a second FEMA study map that had a larger coverage area of the Soda Mountain region and the town of Baker, California (FEMA 2023). Between Baker and east of Soda Mountain lies a floodplain Zone A, which indicates areas with a 1% annual chance of flooding. The FEMA maps are provided in Appendix A.

3 MODEL RESULTS

Hydrographs were generated for each simulation at two locations where flow leaves the site, as shown in Figure 2. Figure 3 and Figure 4 show the change in stormwater runoff to the south and north of the site, respectively, for the 2-year storm event. No grading of the proposed condition was conducted by the site development engineer for the 30% design milestone. Proposed berms and channels were added directly into the hydraulic model terrain by SWCA based on the alignments and section geometries provided in the 30% design. Future refinement of the site design to include grading of the proposed solar array areas to drain into the detention basins will be required to mitigate these increases in stormwater runoff. Peak flows for a 10-year events of the proposed condition are expected to be the same to the existing condition (Figure 5 Figure 6. A decrease in peak flow for the proposed condition is predicted in the 100-year hydrographs at south side of the site, due to the capacity of the retention ponds, while no significant change at the north side (Figure 7 and Figure 8).

Exhibits were prepared illustrating the predicted spatial distributions of depth and velocity for existing and proposed conditions under the 2-year, 10-year, and 100-year storm events (Appendix D). These maps clearly indicate areas where hazardous flow depths and velocities are expected to be present in the site and surrounding area during these events.

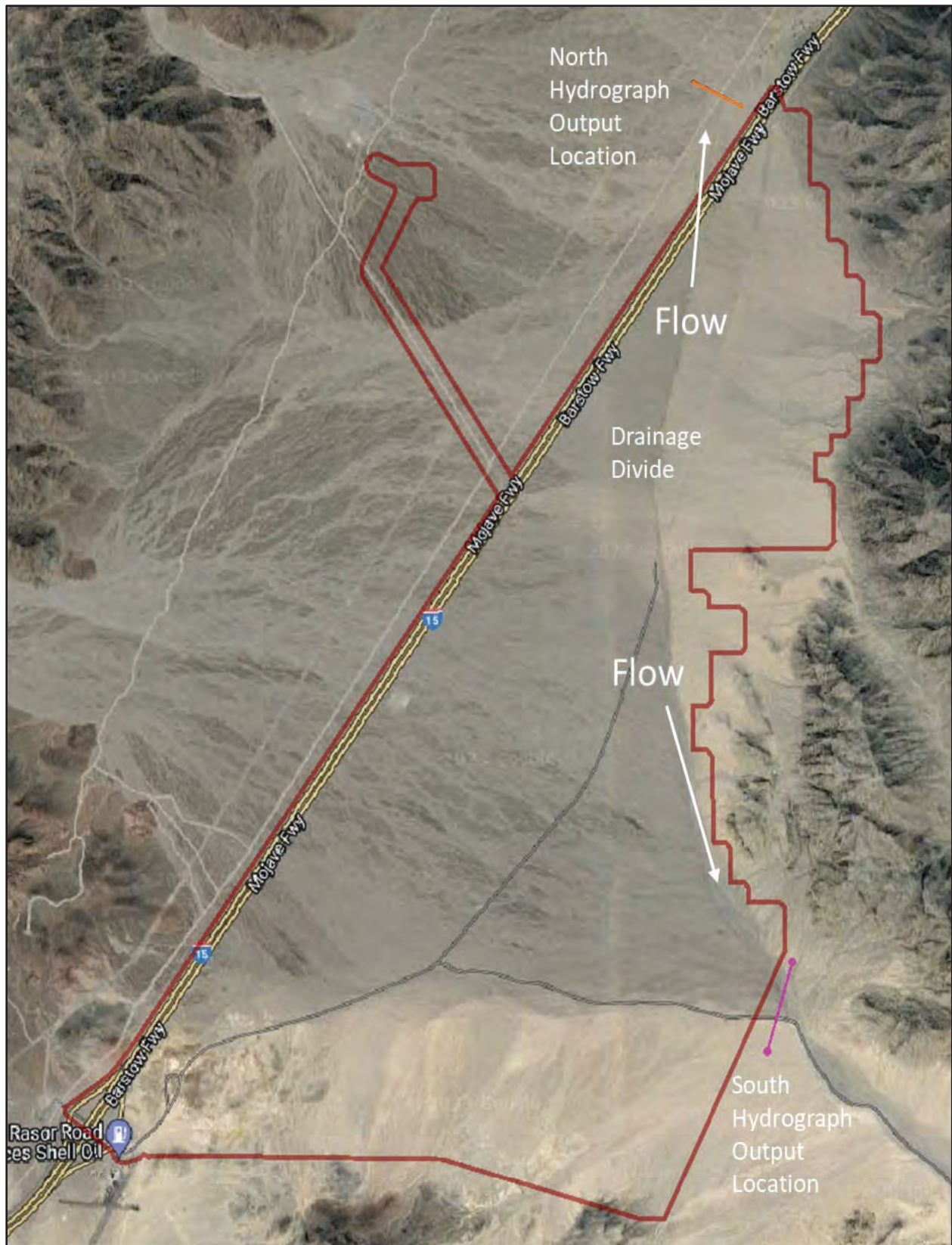

Figure 2. Overview of project site showing locations of hydrograph output locations and drainage divide.

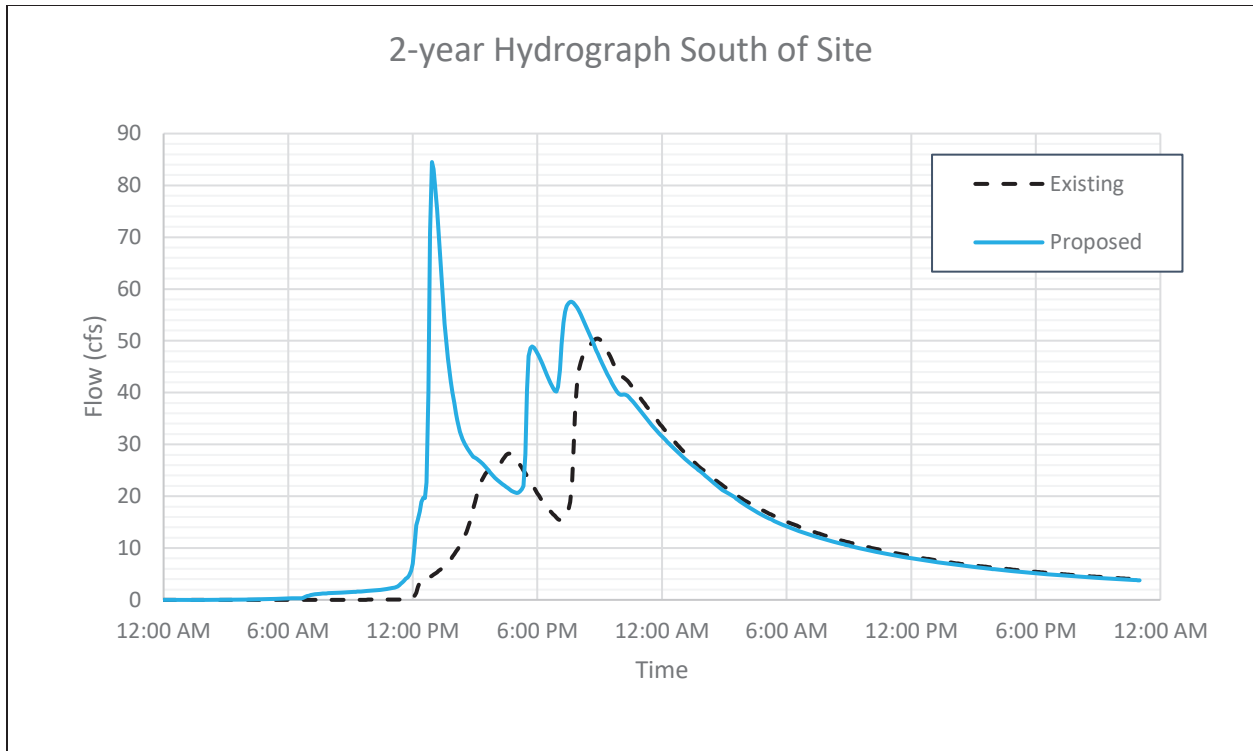

Figure 3. 2-year hydrograph of flow exiting the site to the south, proposed condition showing a significant increase and change in timing in stormwater runoff compared to existing condition.

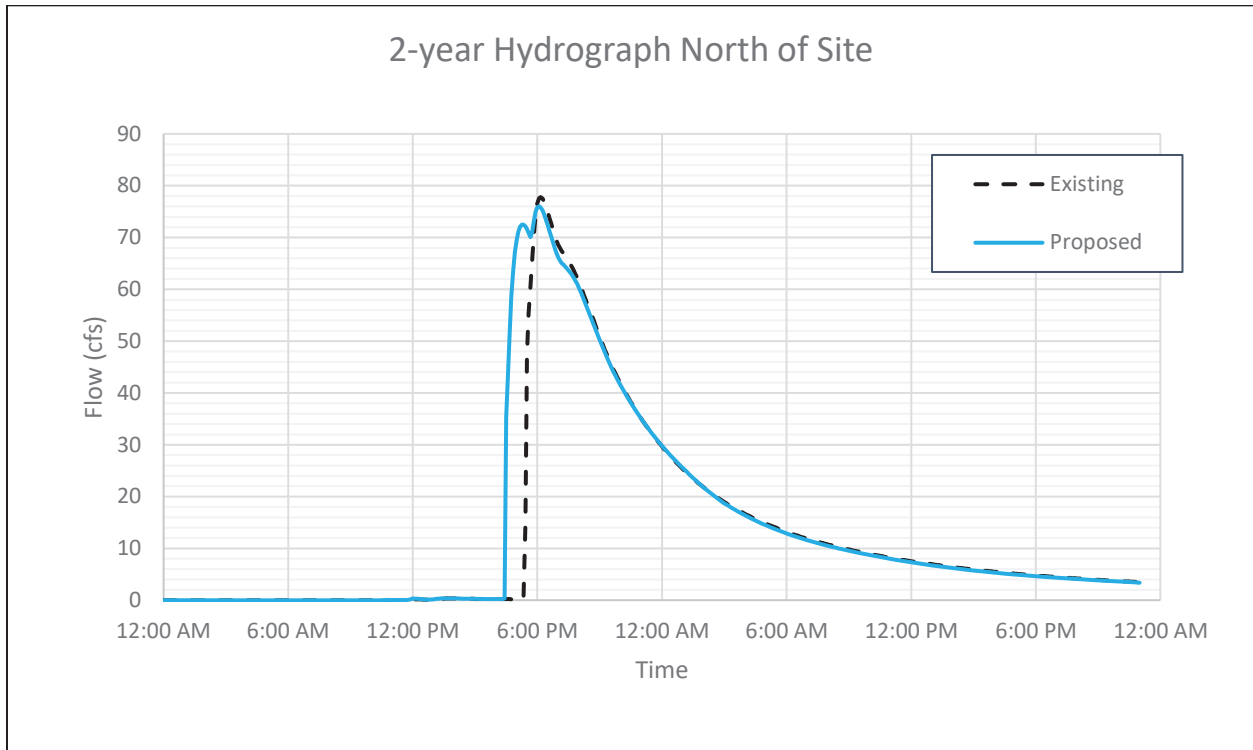

Figure 4. 2-year hydrograph of flow existing to the north of the site, proposed condition showing a small decrease in peak flow.

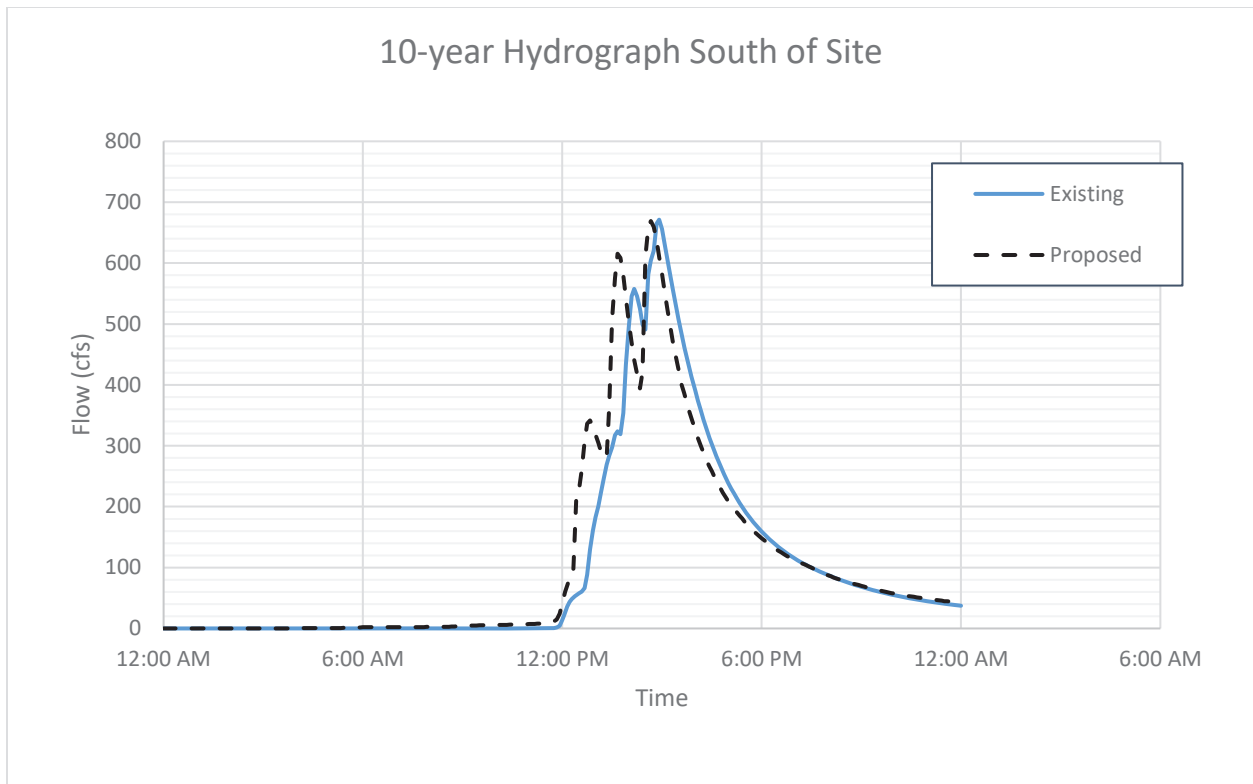

Figure 5. 10-year hydrograph of flow exiting the site to the south, showing no change in peak stormwater runoff among existing and proposed conditions.

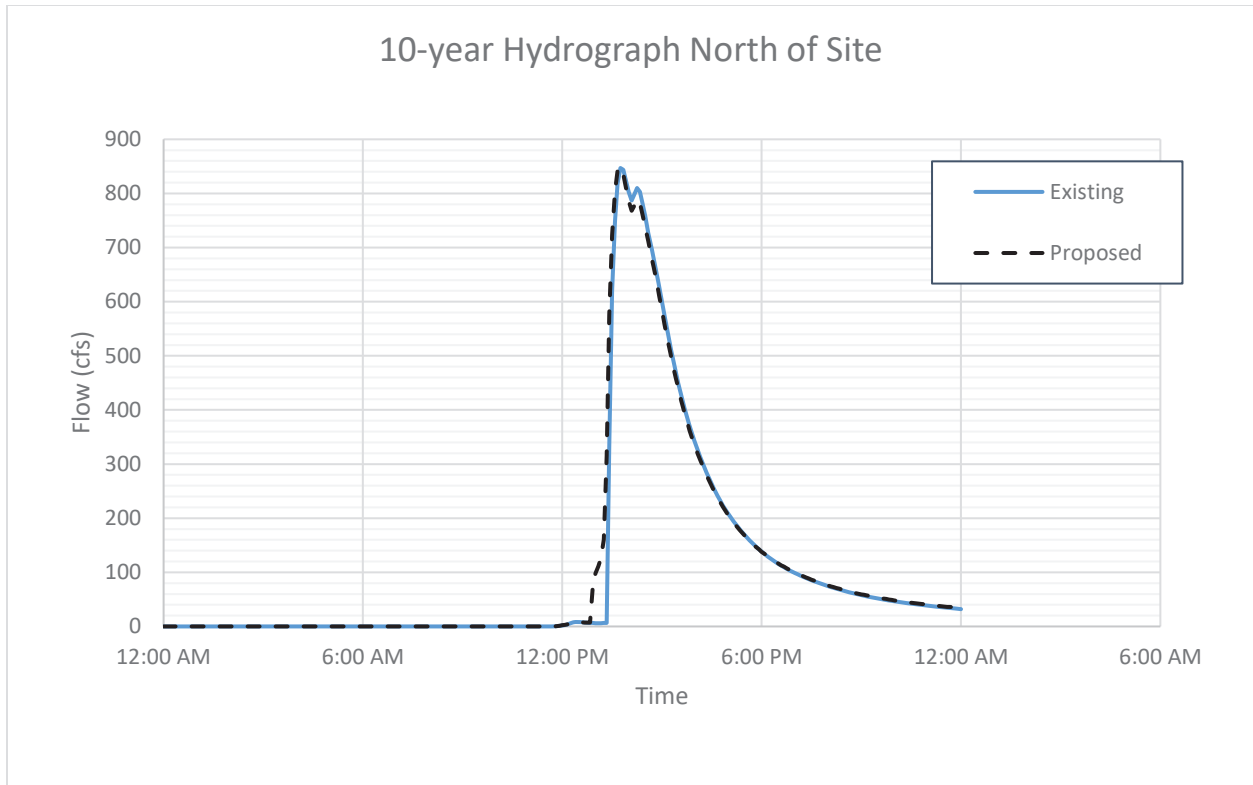

Figure 6. 10-year hydrograph of flow exiting the site to the north, showing no change in peak stormwater runoff among existing and proposed conditions.

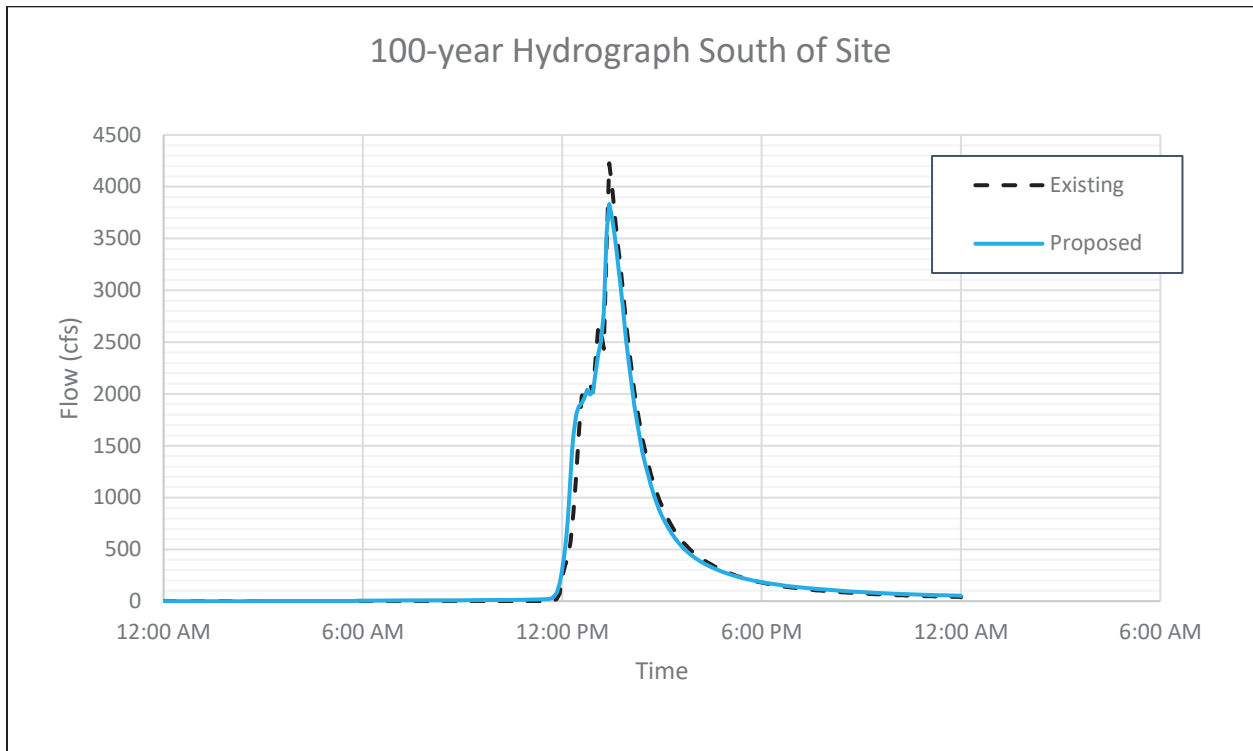

Figure 7. 100-year hydrograph of flow exiting the site to the south, proposed condition showing decrease in peak stormwater runoff compared to existing condition.

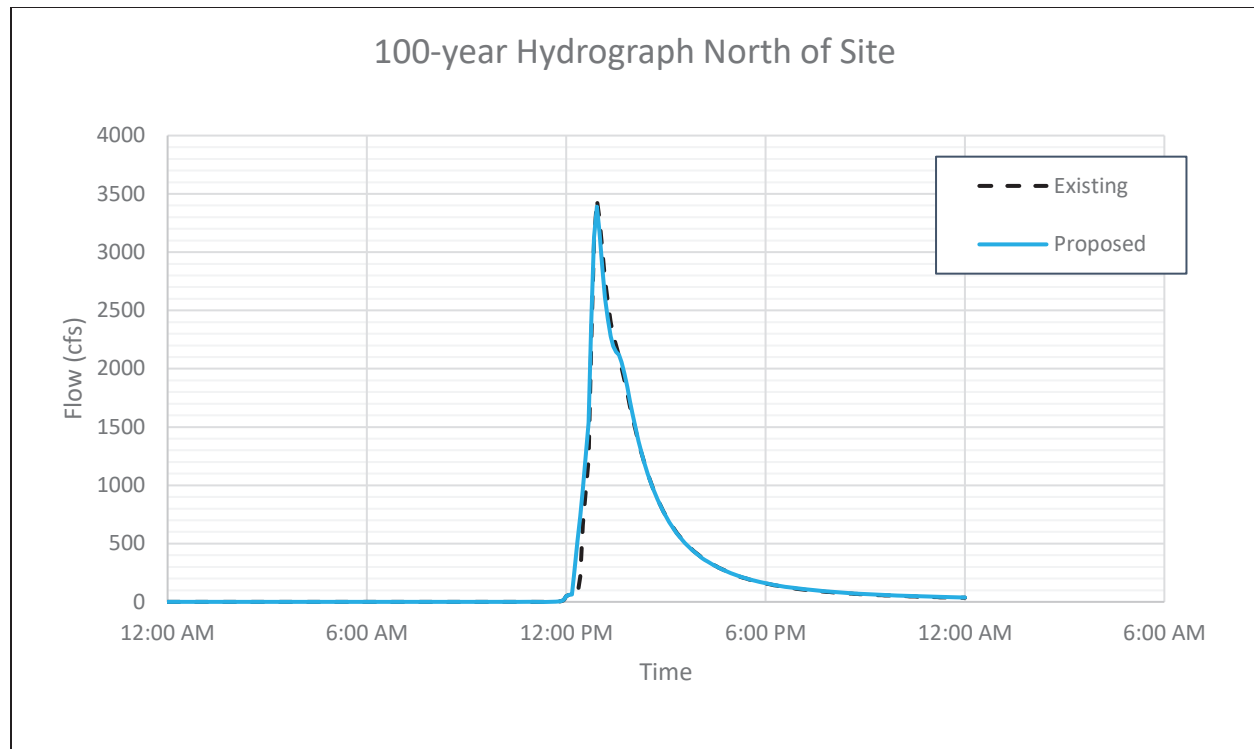

Figure 8. 100-year hydrograph of flow exiting the site to the north, showing no significant change in stormwater runoff.

4 LITERATURE CITED

Best Available Map (BAM). 2024. California Department of Water Resources. Search by Address. Available at: gis.bam.water.ca.gov/bam/. Access June 2024.

Federal Emergency Management Agency (FEMA). 2023. Flood Map Service Center: Search by Address. Available at: msc.fema.gov. Accessed May 22, 2023.

Multi-Resolution Land Characteristics Consortium. 2019. *NLCD 2019 Land Cover (CONUS)*. Available at: www.mrlc.gov/data/nlcd-2019-land-cover-conus. Accessed May 22, 2023.

National Oceanic and Atmospheric Administration (NOAA). 2023. Precipitation Frequency Data Server (PFDS), PF Data Server-PFDS/HDSC/OWP. Available at: hdsc.nws.noaa.gov/hdsc/pfds/. Accessed May 22, 2023.

National Weather Service (NWS). 2024. Past Weather. Available at: www.weather.gov/wrh/climate. Accessed June 05, 2024.

URS Land Management Consulting Group. 2009. Jurisdictional Determination Report.

APPENDIX A

Miscellaneous Site Data

FEMA Flood Hazard

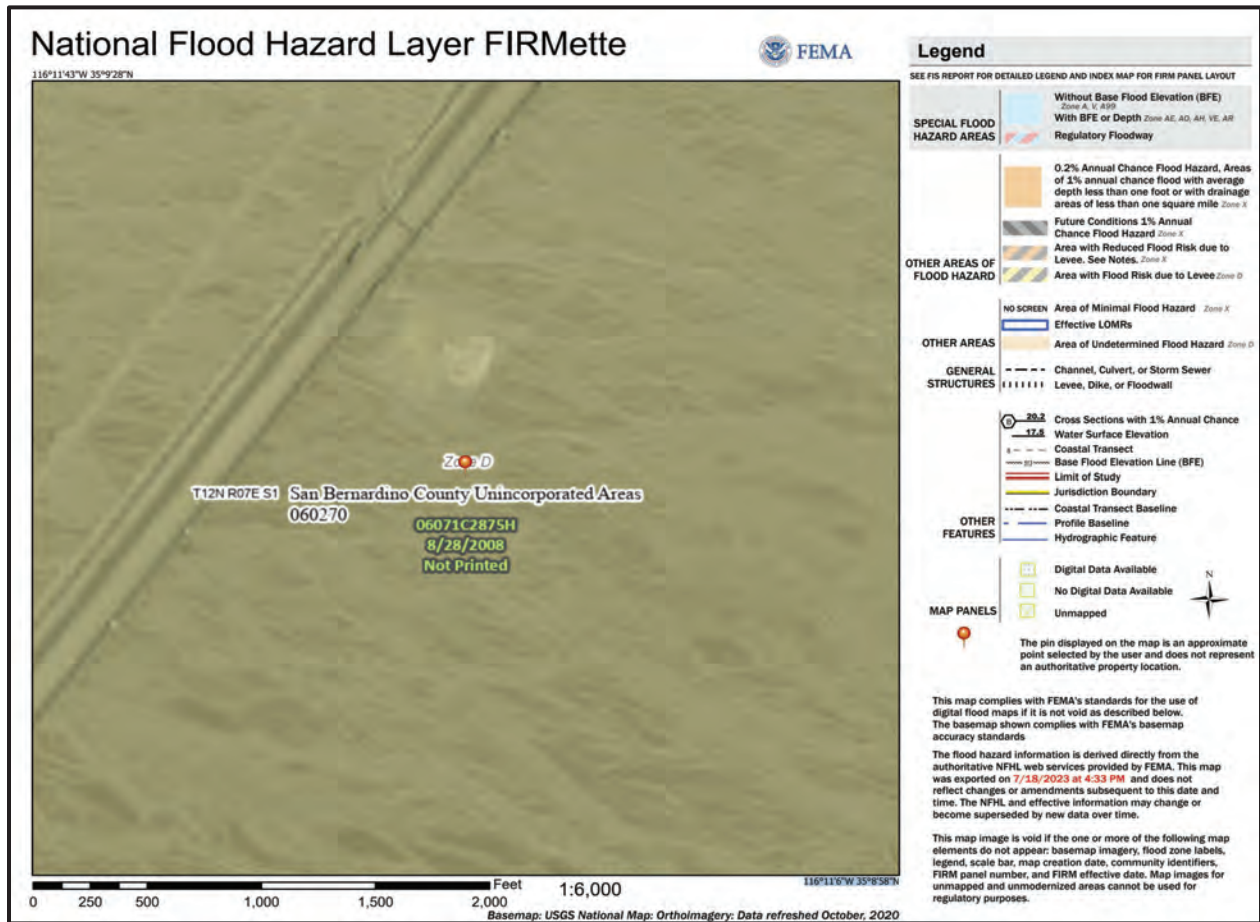

Source: FEMA (2023)

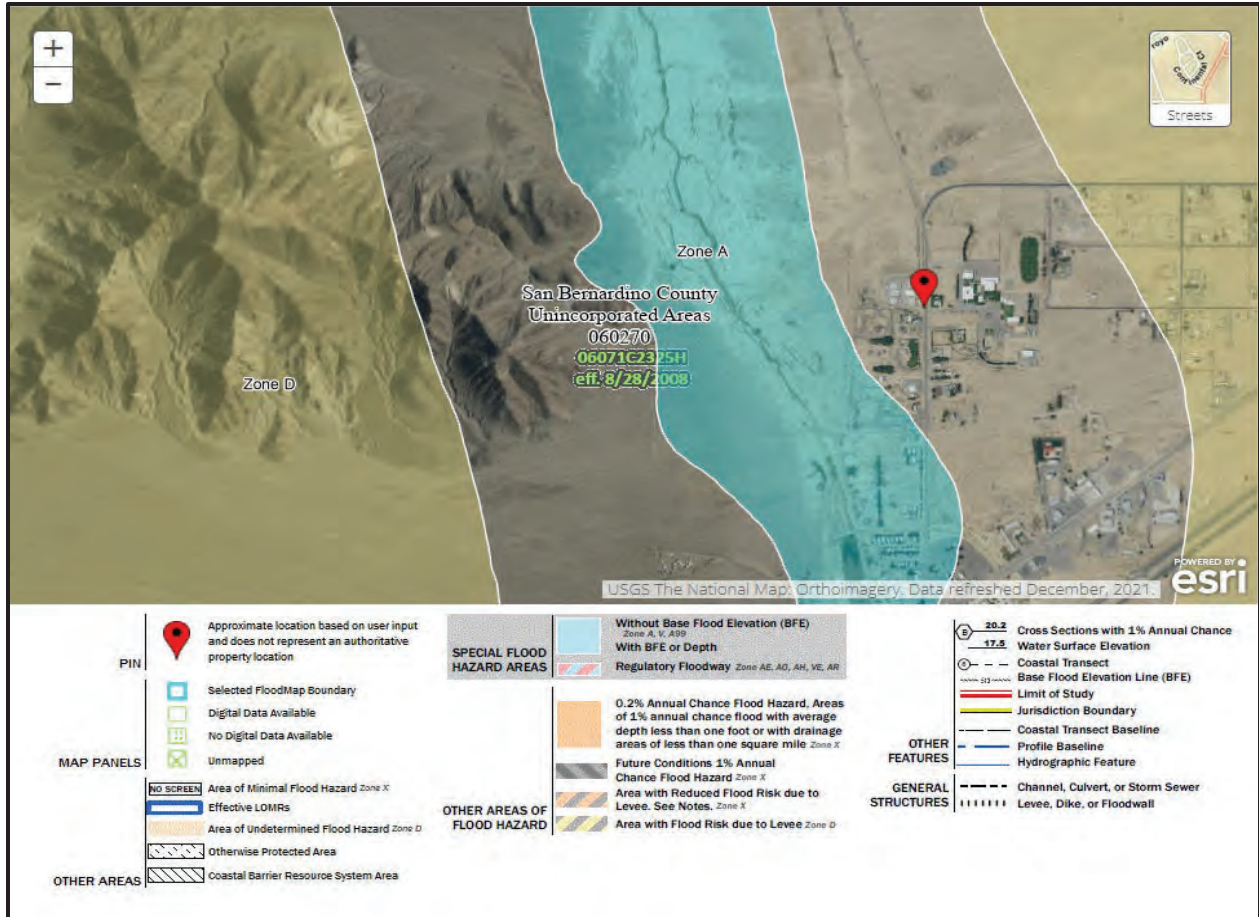

Source: FEMA (2023)

APPENDIX B

Rainfall Data

Point Precipitation Frequency Estimates by NOAA

PF tabular										
PDS-based point precipitation frequency estimates with 90% confidence intervals (in inches)¹										
Duration	Average recurrence interval (years)									
	1	2	5	10	25	50	100	200	500	1000
5-min	0.063 (0.052-0.078)	0.108 (0.088-0.133)	0.166 (0.135-0.205)	0.214 (0.173-0.267)	0.279 (0.219-0.360)	0.330 (0.254-0.434)	0.382 (0.287-0.514)	0.436 (0.319-0.603)	0.511 (0.359-0.734)	0.569 (0.387-0.846)
10-min	0.091 (0.074-0.112)	0.154 (0.126-0.191)	0.238 (0.194-0.294)	0.306 (0.248-0.382)	0.400 (0.314-0.516)	0.473 (0.364-0.622)	0.548 (0.411-0.737)	0.625 (0.457-0.864)	0.732 (0.514-1.05)	0.816 (0.555-1.21)
15-min	0.110 (0.090-0.136)	0.186 (0.152-0.230)	0.287 (0.234-0.356)	0.370 (0.300-0.462)	0.484 (0.379-0.624)	0.572 (0.440-0.752)	0.662 (0.497-0.891)	0.756 (0.553-1.04)	0.885 (0.622-1.27)	0.987 (0.671-1.47)
30-min	0.151 (0.124-0.187)	0.257 (0.210-0.317)	0.396 (0.323-0.490)	0.510 (0.413-0.637)	0.666 (0.522-0.859)	0.788 (0.605-1.04)	0.912 (0.685-1.23)	1.04 (0.761-1.44)	1.22 (0.857-1.75)	1.36 (0.924-2.02)
60-min	0.209 (0.171-0.258)	0.355 (0.290-0.439)	0.548 (0.447-0.678)	0.705 (0.571-0.881)	0.922 (0.723-1.19)	1.09 (0.837-1.43)	1.26 (0.947-1.70)	1.44 (1.05-1.99)	1.69 (1.18-2.42)	1.88 (1.28-2.79)
2-hr	0.294 (0.241-0.363)	0.447 (0.365-0.552)	0.654 (0.533-0.810)	0.829 (0.671-1.04)	1.08 (0.844-1.39)	1.27 (0.979-1.67)	1.48 (1.11-1.99)	1.70 (1.24-2.35)	2.01 (1.42-2.90)	2.27 (1.54-3.37)
3-hr	0.337 (0.276-0.416)	0.492 (0.402-0.608)	0.706 (0.576-0.875)	0.889 (0.719-1.11)	1.15 (0.902-1.48)	1.36 (1.05-1.79)	1.59 (1.19-2.13)	1.83 (1.34-2.53)	2.17 (1.53-3.12)	2.46 (1.67-3.65)
6-hr	0.417 (0.341-0.514)	0.585 (0.478-0.723)	0.820 (0.669-1.02)	1.02 (0.828-1.28)	1.32 (1.03-1.70)	1.56 (1.20-2.05)	1.82 (1.37-2.45)	2.11 (1.54-2.91)	2.52 (1.77-3.62)	2.86 (1.94-4.25)
12-hr	0.503 (0.412-0.621)	0.707 (0.578-0.873)	0.991 (0.808-1.23)	1.24 (1.00-1.54)	1.59 (1.25-2.05)	1.88 (1.44-2.47)	2.19 (1.64-2.95)	2.53 (1.85-3.50)	3.02 (2.12-4.34)	3.43 (2.33-5.09)
24-hr	0.673 (0.594-0.778)	0.959 (0.846-1.11)	1.35 (1.19-1.57)	1.68 (1.47-1.97)	2.16 (1.83-2.60)	2.54 (2.11-3.12)	2.94 (2.39-3.69)	3.38 (2.68-4.34)	3.99 (3.05-5.33)	4.49 (3.32-6.19)
2-day	0.786 (0.694-0.909)	1.11 (0.982-1.29)	1.55 (1.37-1.80)	1.92 (1.68-2.25)	2.44 (2.07-2.94)	2.85 (2.37-3.50)	3.28 (2.67-4.12)	3.74 (2.96-4.81)	4.37 (3.34-5.84)	4.88 (3.61-6.73)
3-day	0.854 (0.753-0.987)	1.20 (1.06-1.39)	1.67 (1.47-1.94)	2.06 (1.80-2.40)	2.60 (2.20-3.13)	3.02 (2.51-3.71)	3.47 (2.82-4.35)	3.93 (3.12-5.06)	4.58 (3.49-6.12)	5.09 (3.77-7.02)
4-day	0.912 (0.805-1.06)	1.28 (1.13-1.48)	1.77 (1.56-2.05)	2.17 (1.90-2.54)	2.73 (2.32-3.29)	3.17 (2.64-3.90)	3.63 (2.95-4.55)	4.10 (3.25-5.28)	4.76 (3.64-6.36)	5.28 (3.91-7.29)
7-day	0.982 (0.867-1.14)	1.36 (1.20-1.58)	1.86 (1.64-2.16)	2.27 (1.98-2.66)	2.84 (2.40-3.42)	3.28 (2.73-4.02)	3.73 (3.04-4.68)	4.21 (3.34-5.41)	4.86 (3.71-6.49)	5.37 (3.98-7.41)
10-day	1.05 (0.927-1.22)	1.45 (1.28-1.68)	1.97 (1.73-2.28)	2.40 (2.09-2.80)	2.98 (2.53-3.59)	3.44 (2.86-4.22)	3.90 (3.17-4.89)	4.38 (3.48-5.64)	5.05 (3.85-6.74)	5.57 (4.12-7.68)
20-day	1.18 (1.05-1.37)	1.62 (1.42-1.87)	2.18 (1.92-2.53)	2.64 (2.30-3.08)	3.26 (2.76-3.93)	3.74 (3.11-4.60)	4.24 (3.44-5.32)	4.75 (3.76-6.11)	5.44 (4.16-7.28)	5.99 (4.43-8.26)
30-day	1.33 (1.18-1.54)	1.81 (1.60-2.09)	2.43 (2.14-2.82)	2.94 (2.56-3.43)	3.62 (3.07-4.37)	4.16 (3.46-5.10)	4.70 (3.82-5.89)	5.26 (4.17-6.77)	6.03 (4.60-8.05)	6.63 (4.91-9.15)
45-day	1.50 (1.32-1.74)	2.03 (1.79-2.35)	2.72 (2.40-3.16)	3.29 (2.87-3.84)	4.05 (3.43-4.88)	4.64 (3.85-5.69)	5.24 (4.26-6.57)	5.86 (4.64-7.54)	6.71 (5.13-8.97)	7.39 (5.47-10.2)
60-day	1.63 (1.44-1.88)	2.20 (1.94-2.54)	2.94 (2.58-3.41)	3.54 (3.09-4.14)	4.36 (3.69-5.25)	4.99 (4.15-6.12)	5.63 (4.58-7.06)	6.30 (5.00-8.11)	7.22 (5.52-9.66)	7.96 (5.89-11.0)

¹ Precipitation frequency (PF) estimates in this table are based on frequency analysis of partial duration series (PDS). Numbers in parenthesis are PF estimates at lower and upper bounds of the 90% confidence interval. The probability that precipitation frequency estimates (for a given duration and average recurrence interval) will be greater than the upper bound (or less than the lower bound) is 5%. Estimates at upper bounds are not checked against probable maximum precipitation (PMP) estimates and may be higher than currently valid PMP values. Please refer to NOAA Atlas 14 document for more information.

Source: NOAA (2023)

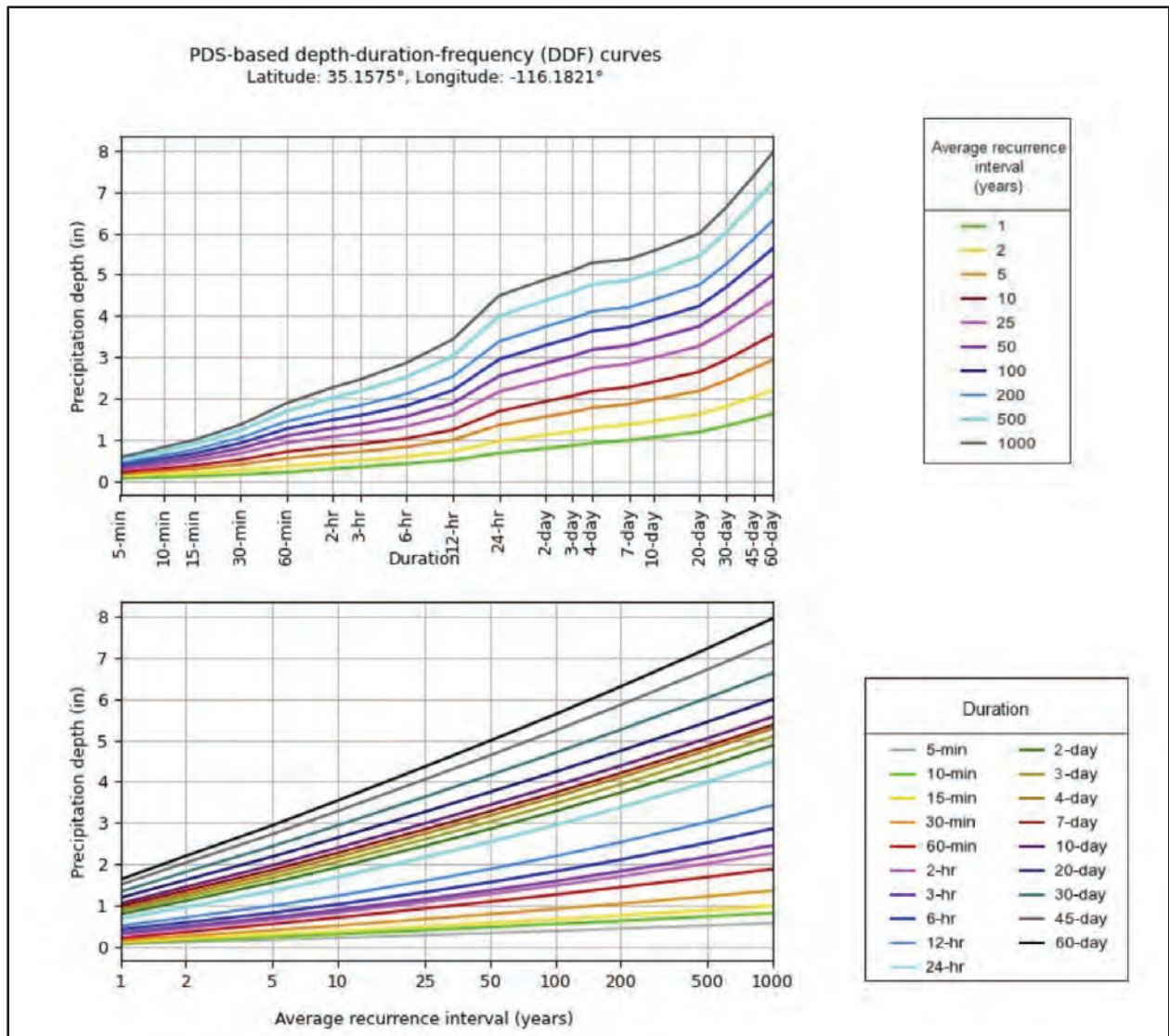

Source: NOAA (2023)

Precipitation Hyetograph

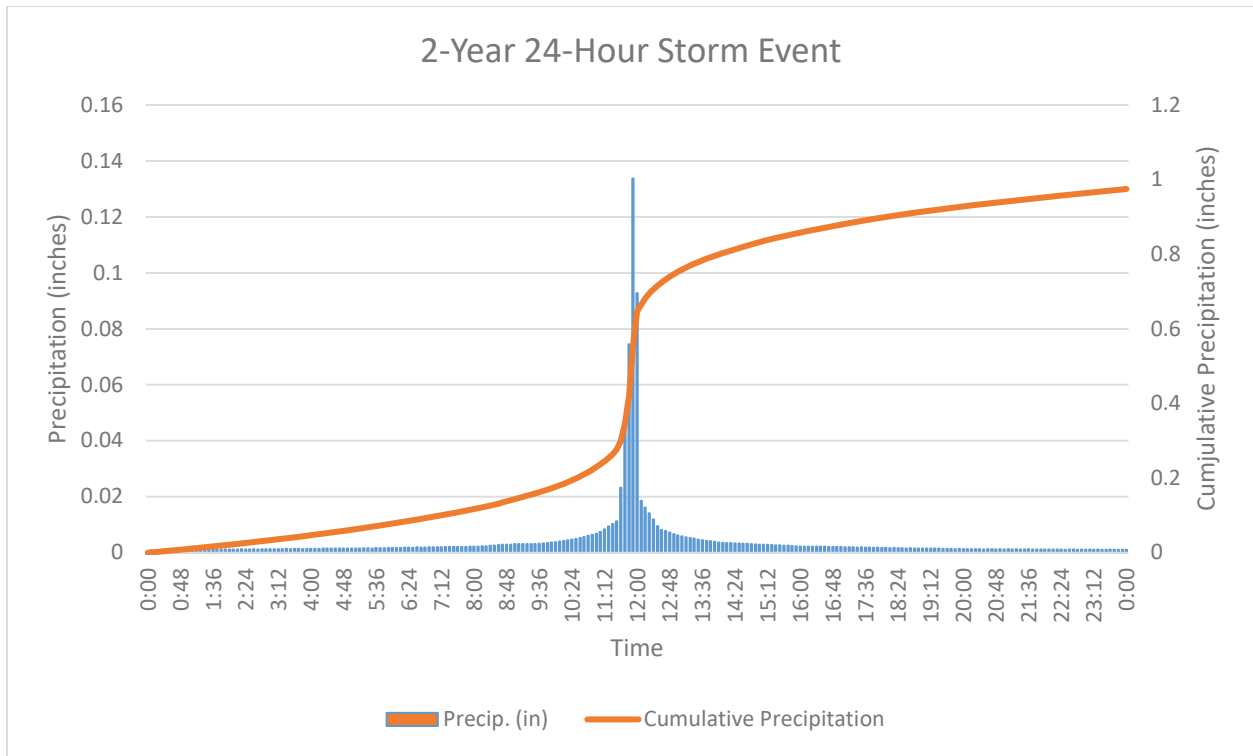

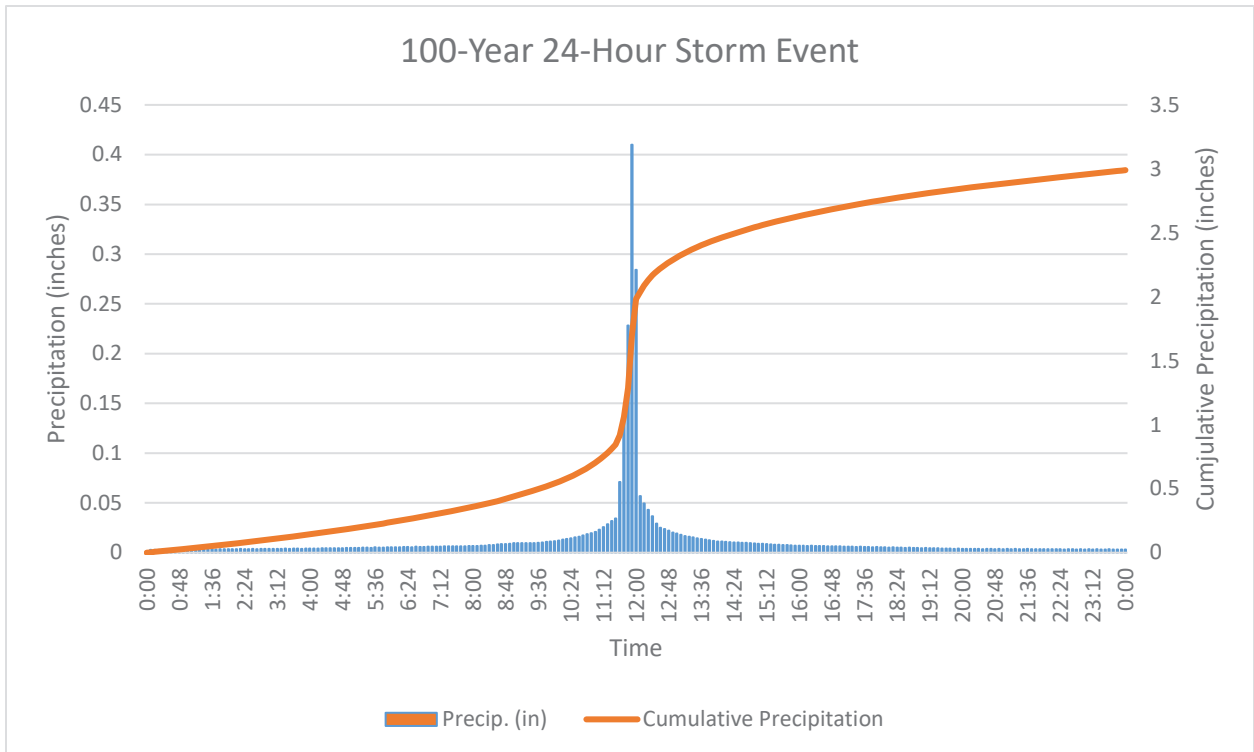
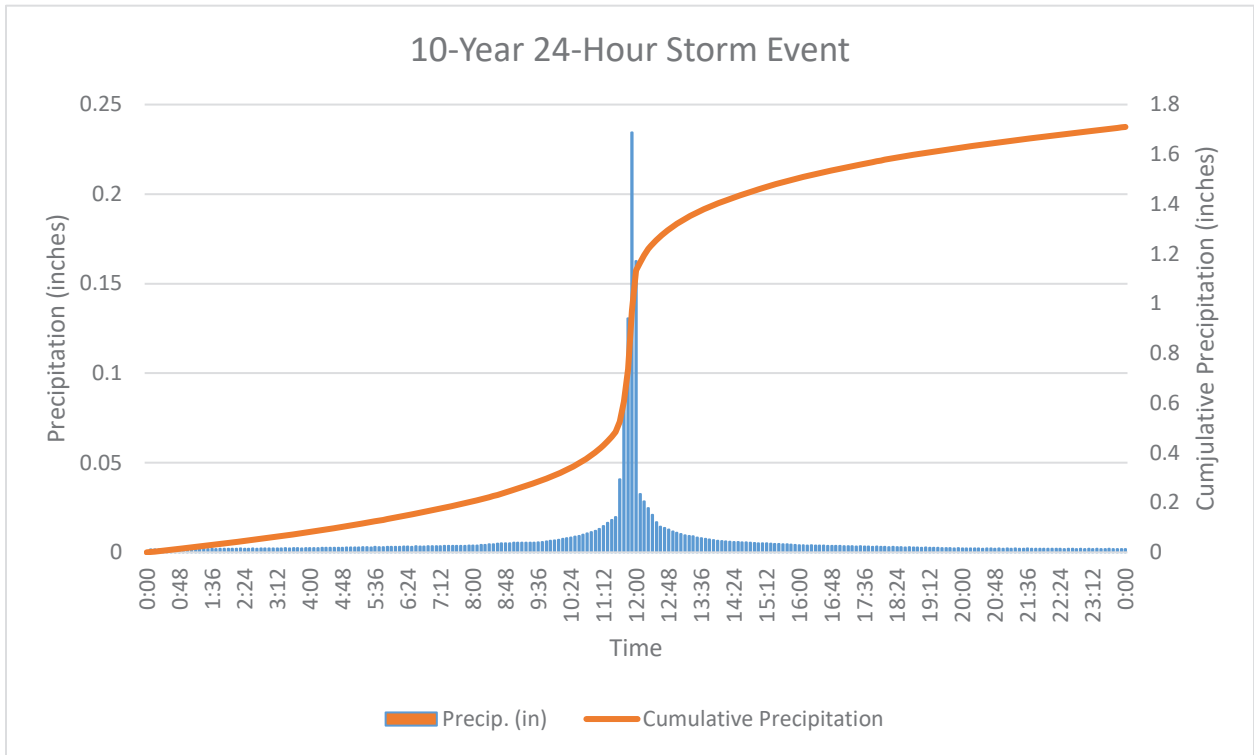

APPENDIX C

Soils and Land Cover Data

Pre-Development Land Cover Exhibit

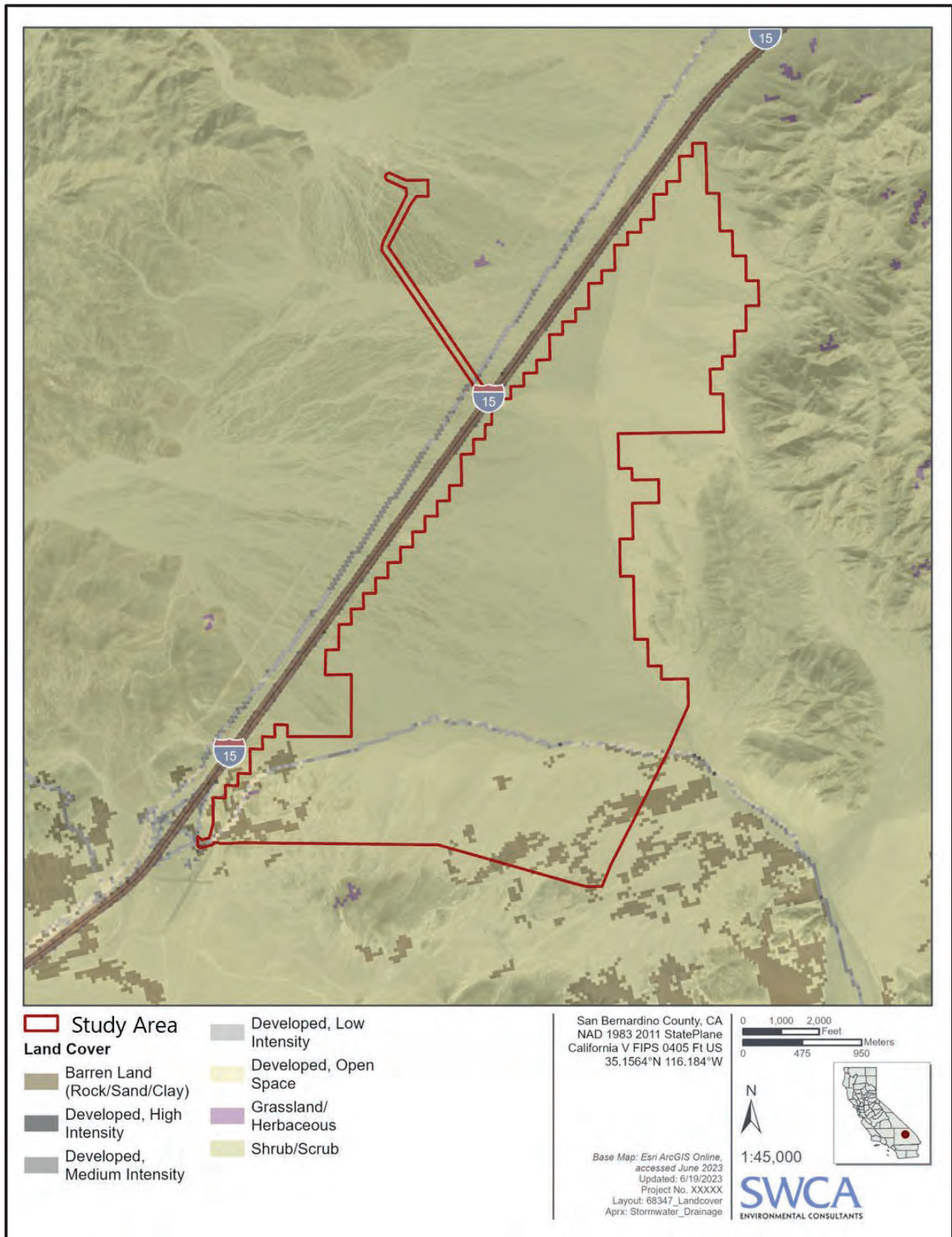

Post-Development Land Cover Exhibit

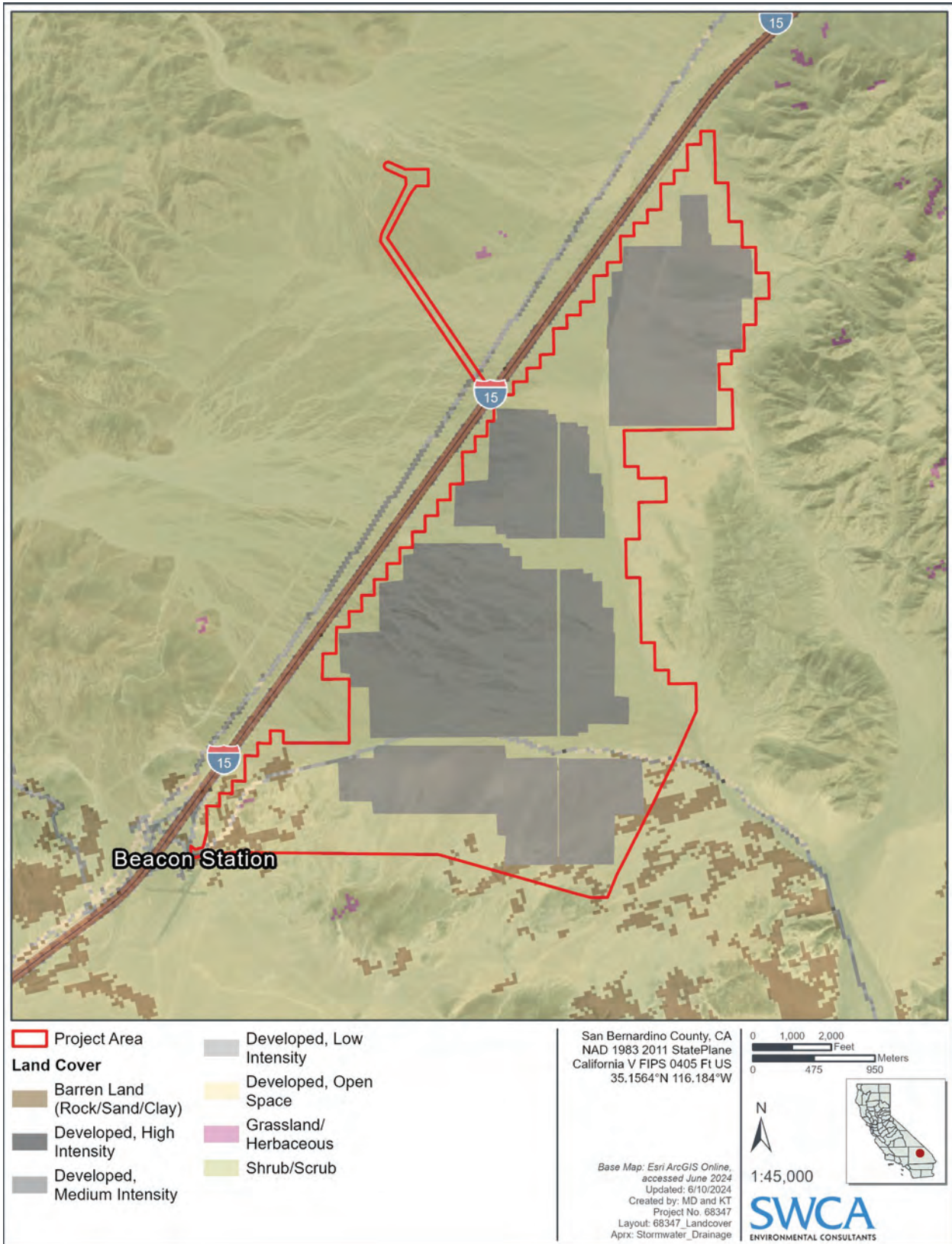

Pre-Development and Post-Development Land Cover Roughness and Percent Impervious Area

ID	Name	ManningsN	Percent Impervious
0	NoData	0.066	0
52	Shrub-Scrub	0.06	0
31	Barren Land Rock-Sand-Clay	0.025	0
22	Developed, Low Intensity	0.09	20
21	Developed, Open Space	0.03	10
71	Grassland-Herbaceous	0.04	0
23	Developed, Medium Intensity	0.1	40
24	Developed, High Intensity	0.15	80
90	Woody Wetlands	0.09	0
11	Open Water	0.035	100
42	Evergreen Forest	0.15	0
43	Mixed Forest	0.1	0
95	Emergent Herbaceous Wetlan...	0.075	0
81	Pasture-Hay	0.035	0
82	Cultivated Crops	0.035	0
41	Deciduous Forest	0.15	0

Natural Resources Conservation Service Soils Information

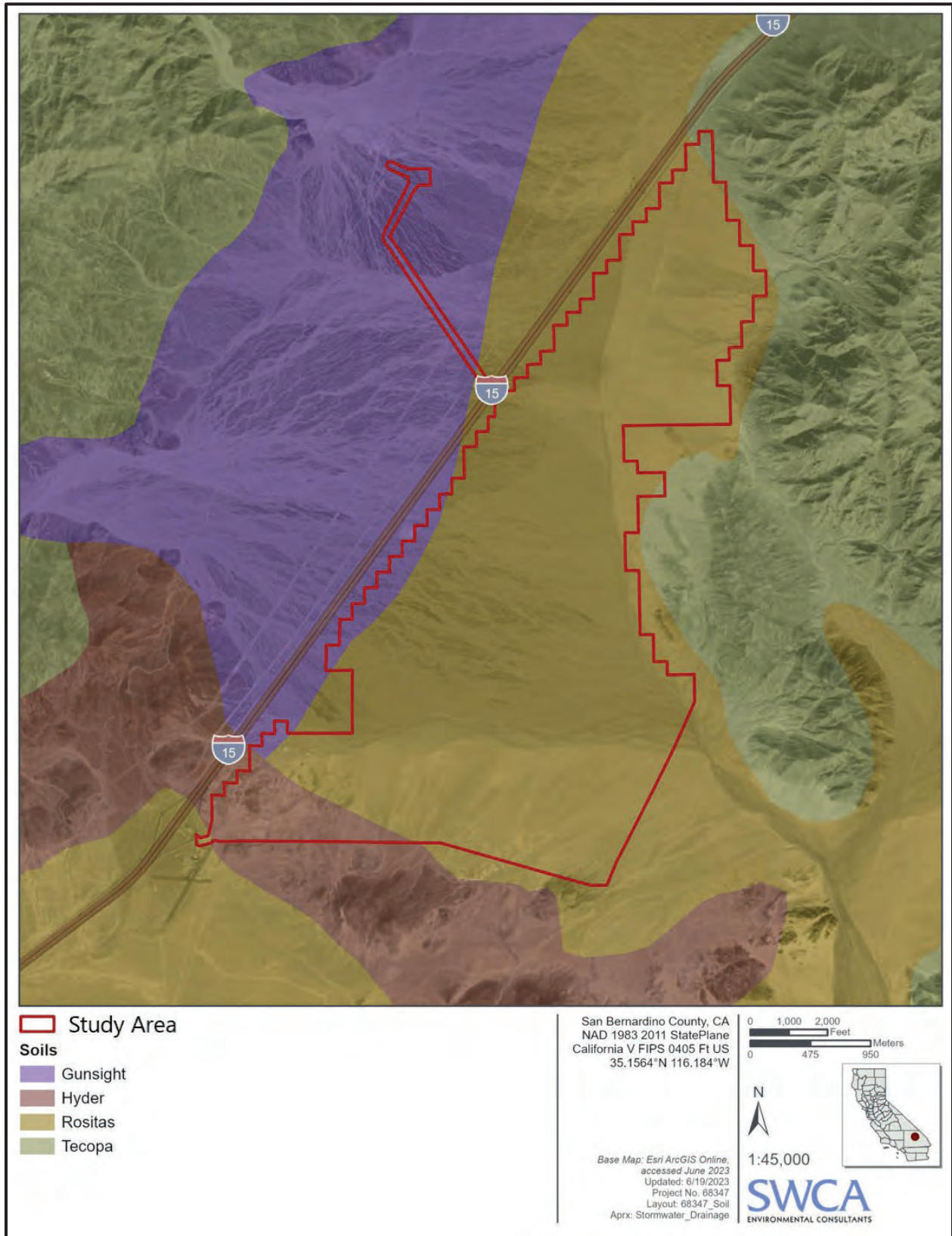

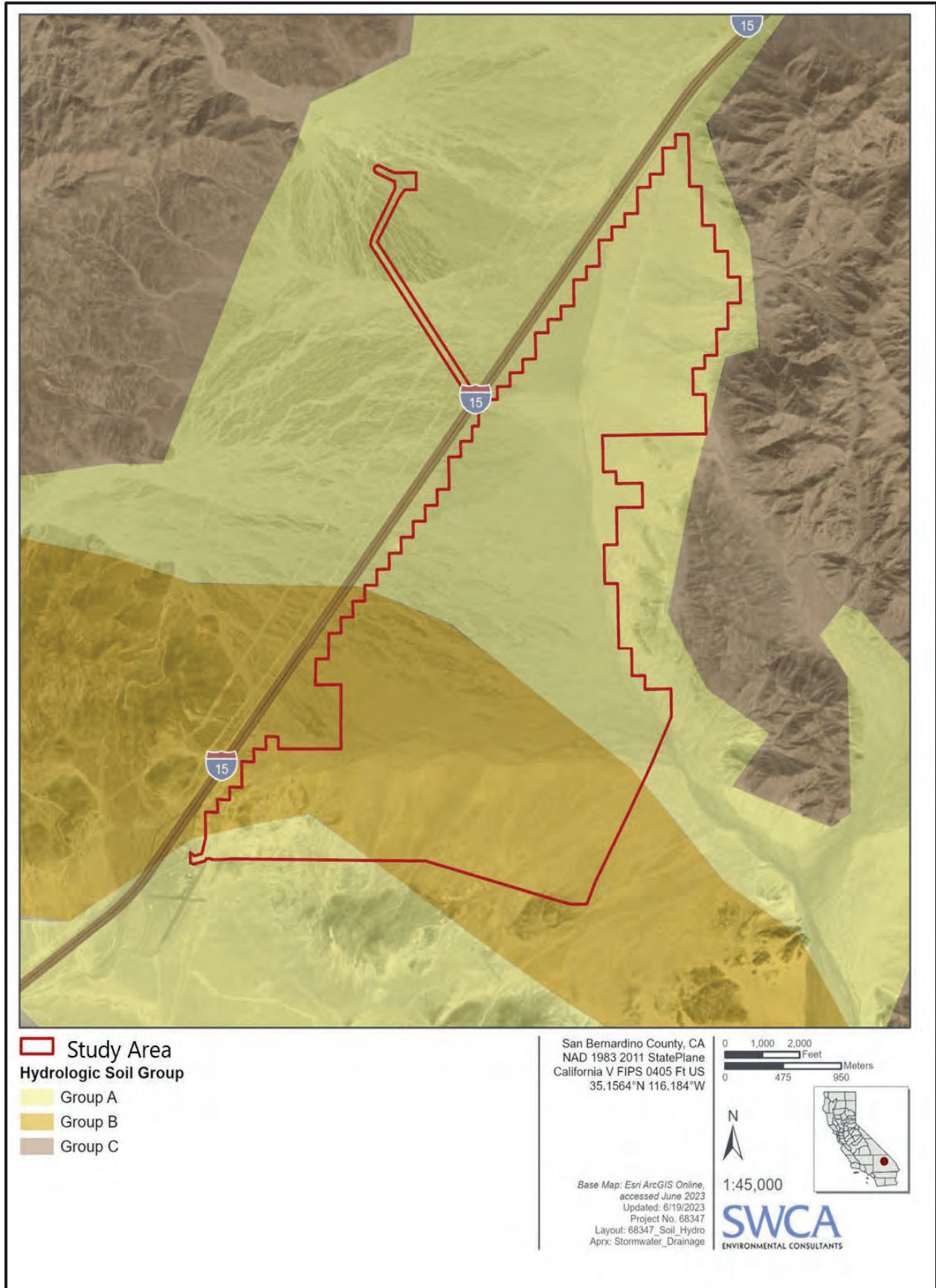

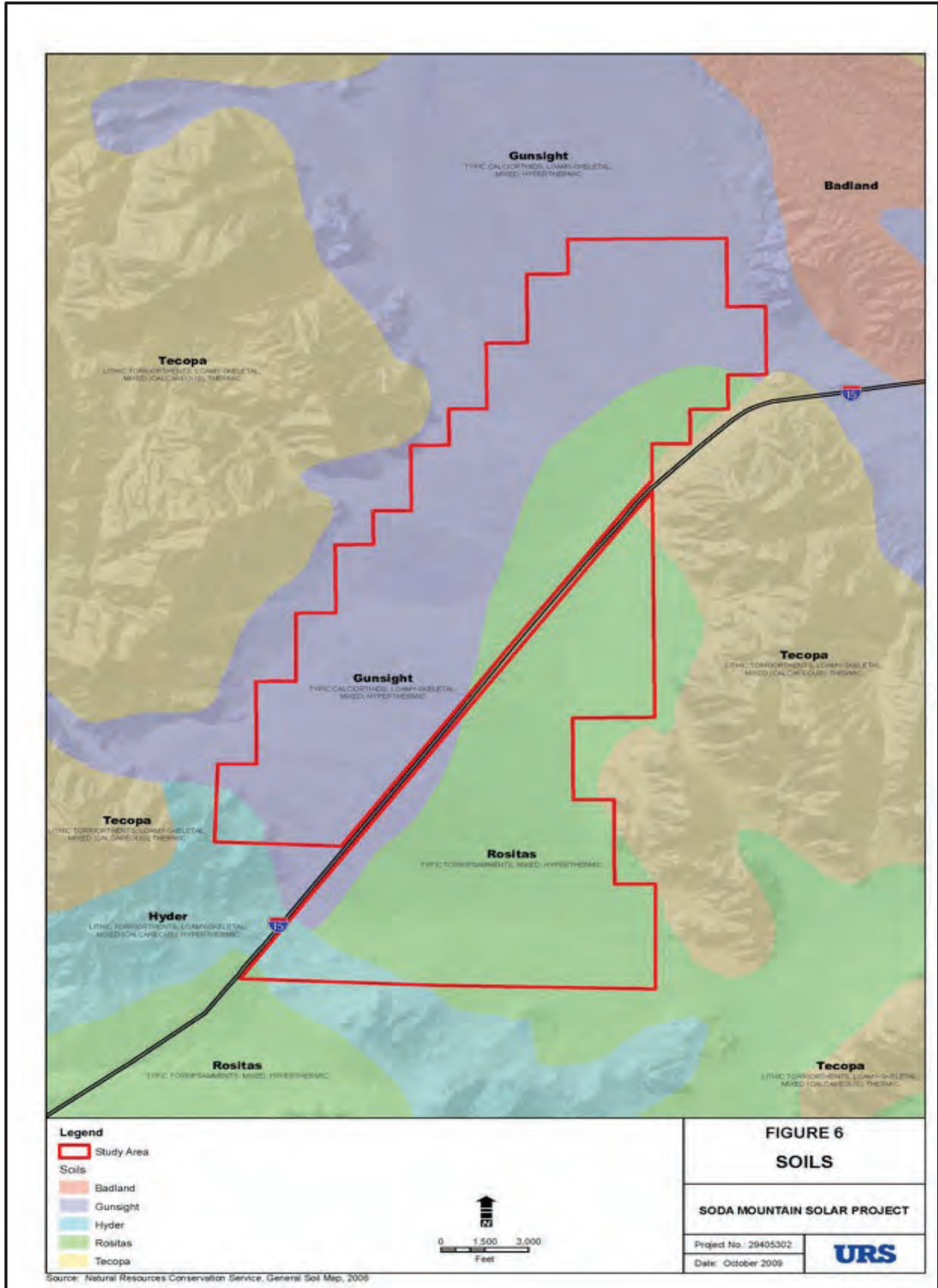

Table 2. Permissible Shear and Velocity for Selected Lining Materials¹

Boundary Category	Boundary Type	Permissible Shear Stress (lb/sq ft)	Permissible Velocity (ft/sec)	Citation(s)	
<u>Soils</u>	Fine colloidal sand	0.02 - 0.03	1.5	A	
	Sandy loam (noncolloidal)	0.03 - 0.04	1.75	A	
	Alluvial silt (noncolloidal)	0.045 - 0.05	2	A	
	Silty loam (noncolloidal)	0.045 - 0.05	1.75 - 2.25	A	
	Firm loam	0.075	2.5	A	
	Fine gravels	0.075	2.5	A	
	Stiff clay	0.26	3 - 4.5	A, F	
	Alluvial silt (colloidal)	0.26	3.75	A	
	Graded loam to cobbles	0.38	3.75	A	
	Graded silts to cobbles	0.43	4	A	
	Shales and hardpan	0.67	6	A	
	<u>Gravel/Cobble</u>	1-in.	0.33	2.5 - 5	A
		2-in.	0.67	3 - 6	A
6-in.		2.0	4 - 7.5	A	
12-in.		4.0	5.5 - 12	A	
<u>Vegetation</u>	Class A turf	3.7	6 - 8	E, N	
	Class B turf	2.1	4 - 7	E, N	
	Class C turf	1.0	3.5	E, N	
	Long native grasses	1.2 - 1.7	4 - 6	G, H, L, N	
	Short native and bunch grass	0.7 - 0.95	3 - 4	G, H, L, N	
	Reed plantings	0.1-0.6	N/A	E, N	
	Hardwood tree plantings	0.41-2.5	N/A	E, N	
<u>Temporary Degradable RECPs</u>	Jute net	0.45	1 - 2.5	E, H, M	
	Straw with net	1.5 - 1.65	1 - 3	E, H, M	
	Coconut fiber with net	2.25	3 - 4	E, M	
	Fiberglass roving	2.00	2.5 - 7	E, H, M	
<u>Non-Degradable RECPs</u>	Unvegetated	3.00	5 - 7	E, G, M	
	Partially established	4.0-6.0	7.5 - 15	E, G, M	
	Fully vegetated	8.00	8 - 21	F, L, M	
<u>Riprap</u>	6 - in. d_{50}	2.5	5 - 10	H	
	9 - in. d_{50}	3.8	7 - 11	H	
	12 - in. d_{50}	5.1	10 - 13	H	
	18 - in. d_{50}	7.6	12 - 16	H	
	24 - in. d_{50}	10.1	14 - 18	E	
<u>Soil Bioengineering</u>	Wattles	0.2 - 1.0	3	C, I, J, N	
	Reed fascine	0.6-1.25	5	E	
	Coir roll	3 - 5	8	E, M, N	
	Vegetated coir mat	4 - 8	9.5	E, M, N	
	Live brush mattress (initial)	0.4 - 4.1	4	B, E, I	
	Live brush mattress (grown)	3.90-8.2	12	B, C, E, I, N	
	Brush layering (initial/grown)	0.4 - 6.25	12	E, I, N	
	Live fascine	1.25-3.10	6 - 8	C, E, I, J	
	Live willow stakes	2.10-3.10	3 - 10	E, N, O	
<u>Hard Surfacing</u>	Gabions	10	14 - 19	D	
	Concrete	12.5	>18	H	

¹ Ranges of values generally reflect multiple sources of data or different testing conditions.

A. Chang, H.H. (1988).

F. Julien, P.Y. (1995).

K. Sprague, C.J. (1999).

B. Florineth. (1982)

G. Kouwen, N., Li, R. M., and Simons, D.B., (1980).

L. Temple, D.M. (1980).

C. Gerstgraser, C. (1998).

H. Norman, J. N. (1975).

M. TXDOT (1999)

D. Goff, K. (1999).

I. Schiechl, H. M. and R. Stern. (1996).

N. Data from Author (2001)

E. Gray, D.H., and Sotir, R.B. (1996).

J. Schokitsch, A. (1937).

O. USACE (1997).

SCS Curve Numbers and Infiltration Rates

ID	Name	Curve Number	Abstraction Ratio	Minimum Infiltration Rate (in/hr)
0	NoData	90	0.2	0.14
1	NoData : C	80	0.2	0.18
2	NoData : A	60	0.2	0.41
3	NoData : B	70	0.2	0.27
4	Shrub-Scrub : NoData	92	0.2	0.14
5	Shrub-Scrub : C	92	0.2	0.18
6	Shrub-Scrub : A	83	0.2	0.41
7	Shrub-Scrub : B	89	0.2	0.27
8	Barren Land Rock-Sand-Clay : NoData	92	0.2	0.14
9	Barren Land Rock-Sand-Clay : C	92	0.2	0.18
10	Barren Land Rock-Sand-Clay : A	83	0.2	0.41
11	Barren Land Rock-Sand-Clay : B	89	0.2	0.27
12	Developed, Low Intensity : NoData	90	0.2	0.37
13	Developed, Low Intensity : C	80	0.2	0.45
14	Developed, Low Intensity : A	50	0.2	0.6
15	Developed, Low Intensity : B	65	0.2	0.78
16	Developed, Open Space : NoData	70	0.2	0.8
17	Developed, Open Space : C	70	0.2	0.8
18	Developed, Open Space : A	50	0.2	0.8
19	Developed, Open Space : B	60	0.2	0.8
20	Grassland-Herbaceous : NoData	80	0.2	0.31
21	Grassland-Herbaceous : C	80	0.2	0.4

22	Grassland-Herbaceous : A	70	0.2	0.82
23	Grassland-Herbaceous : B	60	0.2	0.56
24	Developed, Medium Intensity : NoData	85	0.2	0.28
25	Developed, Medium Intensity : C	85	0.2	0.34
26	Developed, Medium Intensity : A	60	0.2	0.58
27	Developed, Medium Intensity : B	77	0.2	0.45
28	Developed, High Intensity : NoData	95	0.2	0.18
29	Developed, High Intensity : C	95	0.2	0.22
30	Developed, High Intensity : A	65	0.2	0.39
31	Developed, High Intensity : B	80	0.2	0.3
32	Woody Wetlands : NoData	75	0.2	0.4
33	Woody Wetlands : C	75	0.2	0.5
34	Woody Wetlands : A	60	0.2	0.95
35	Woody Wetlands : B	45	0.2	0.69
36	Open Water : NoData	98	0.2	0.01
37	Open Water : C	98	0.2	0.01
38	Open Water : A	98	0.2	0.01
39	Open Water : B	98	0.2	0.01
40	Evergreen Forest : NoData	70	0.2	0.4
41	Evergreen Forest : C	70	0.2	0.5
42	Evergreen Forest : A	40	0.2	0.95

43	Evergreen Forest : B	55	0.2	0.69
44	Mixed Forest : NoData	75	0.2	0.4
45	Mixed Forest : C	75	0.2	0.5
46	Mixed Forest : A	60	0.2	0.95
47	Mixed Forest : B	68	0.2	0.69
48	Emergent Herbaceous Wetlands : NoD...	80	0.2	0.4
49	Emergent Herbaceous Wetlands : C	80	0.2	0.5
50	Emergent Herbaceous Wetlands : A	60	0.2	0.95
51	Emergent Herbaceous Wetlands : B	70	0.2	0.69
52	Pasture-Hay : NoData	80	0.2	0.22
53	Pasture-Hay : C	80	0.2	0.29
54	Pasture-Hay : A	60	0.2	0.59
55	Pasture-Hay : B	70	0.2	0.41
56	Cultivated Crops : NoData	80	0.2	0.22
57	Cultivated Crops : C	80	0.2	0.29
58	Cultivated Crops : A	60	0.2	0.59
59	Cultivated Crops : B	70	0.2	0.41
60	Deciduous Forest : NoData	75	0.2	0.4
61	Deciduous Forest : C	75	0.2	0.5
62	Deciduous Forest : A	60	0.2	0.95
63	Deciduous Forest : B	68	0.2	0.69

APPENDIX D

HEC-RAS Model Results

